

# High Torque Vane Motor – MV037 Series

## Technical Data Sheet



- ▶ Maximum operating pressure:
  - 3000 psi (207 bar)
  - Code 61
  - 4500 psi (310 bar)
  - Code 62

### Features

Use: Medium speed, high torque applications requiring reliability in demanding mobile equipment applications. Small size, high torque at start and stall, and through-hole are important features.

- ▶ Six fixed displacement rotating groups ranging from 12 in<sup>3</sup> to 37 in<sup>3</sup> (197 cm<sup>3</sup>/rev to 606 cm<sup>3</sup>/rev)
- ▶ Double stack motors using two ports with displacement from 64 in<sup>3</sup> to 74 in<sup>3</sup> (1049 cm<sup>3</sup>/rev to 1213 cm<sup>3</sup>/rev)
- ▶ 4-port motors from 24 in<sup>3</sup> to 74 in<sup>3</sup> (393 cm<sup>3</sup>/rev to 1213 cm<sup>3</sup>/rev) capable of two-speed operation with external valving
- ▶ Starting and stall torques up to 94% of theoretical torque
- ▶ Speed to 1000 RPM continuous
- ▶ Up to 450 HP (336 kW)
- ▶ Can conform to SAE 'D' mounting specification
- ▶ Customizable for direct drive applications

- ▶ High power to weight ratio
- ▶ High reliability in demanding applications
- ▶ Long service life

---

### Overview of contents

Features	1
Ordering Code	2
Technical Data	5
Unit Dimensions	25
Engineering Guidelines	40

## Ordering code

01	02	03	04	05	06	07	08	09	10								
<b>MV037</b>	-	<b>A2</b>	-	<b>1S</b>	-	<b>012</b>	-	<b>30</b>	-	<b>B1</b>	-	<b>T</b>	<b>B</b>	<b>B</b>	-	<b>000</b>	

01	<b>Motor Series</b>	<b>MV037</b>
----	---------------------	--------------

**Port Options** – Rear port orientation can be specified. Consult factory.

02	<b>Code 61</b>	
	1-1/2" 4 – bolt flange, 2-port	<b>A2</b>
	1-1/2" 4 – bolt flange, 4-port	<b>A4</b>
	<b>SAE 24</b>	
	O-ring boss, 2-port	<b>C2</b>
	O-ring boss, 4-port	<b>C4</b>
	<b>Code 62</b>	
	1-1/4" 4 – bolt flange, 2-port	<b>D2</b>
1-1/4" 4 – bolt flange, 4-port	<b>D4</b>	

### Rotary Group Designation

03	Code 61 – standard speed	<b>1S</b>
	Code 62 – standard speed	<b>2S</b>

### Displacement Options

04	<b>Single rotating group</b>	
	12 in <sup>3</sup> (197 cc)/rev.	<b>012</b>
	16 in <sup>3</sup> (262 cc)/rev.	<b>016</b>
	20 in <sup>3</sup> (328 cc)/rev.	<b>020</b>
	26 in <sup>3</sup> (426 cc)/rev.	<b>026</b>
	32 in <sup>3</sup> (524 cc)/rev.	<b>032</b>
	37 in <sup>3</sup> (606 cc)/rev.	<b>037</b>
	<b>2-port double stack</b>	
	64 in <sup>3</sup> (1049 cc)/rev. – 32/32 rotating groups	<b>064</b>
	69 in <sup>3</sup> (1131 cc)/rev. – 32/37 rotating groups	<b>069</b>
	74 in <sup>3</sup> (1213 cc)/rev. – 37/37 rotating groups	<b>074</b>
	<b>4-port</b>	
	24 in <sup>3</sup> (393 cc)/rev. – 12/12 suitable for series/parallel circuit	<b>024</b>
	28 in <sup>3</sup> (459 cc)/rev. – 12/16 requires logic circuit operation as a two speed	<b>028</b>
	32 in <sup>3</sup> (524 cc)/rev. – 16/16 suitable for series/parallel circuit	<b>032</b>
	32 in <sup>3</sup> (524 cc)/rev. – 12/20 requires logic circuit operation as two speed (alternate combination for 32 cir)	<b>033</b>
	36 in <sup>3</sup> (590 cc)/rev. – 16/20 requires logic circuit operation as a two speed	<b>036</b>
	38 in <sup>3</sup> (623 cc)/rev. – 12/26 requires logic circuit operation as a two speed	<b>038</b>
	40 in <sup>3</sup> (656 cc)/rev. – 20/20 suitable for series/parallel circuit	<b>040</b>
	42 in <sup>3</sup> (688 cc)/rev. – 16/26 requires logic circuit operation as a two speed	<b>042</b>
	44 in <sup>3</sup> (721 cc)/rev. – 12/32 requires logic circuit operation as a two speed	<b>044</b>
	46 in <sup>3</sup> (754 cc)/rev. – 20/26 requires logic circuit operation as a two speed	<b>046</b>
	48 in <sup>3</sup> (787 cc)/rev. – 16/32 requires logic circuit operation as a two speed	<b>048</b>
49 in <sup>3</sup> (803 cc)/rev. – 12/37 requires logic circuit operation as a two speed	<b>049</b>	
52 in <sup>3</sup> (852 cc)/rev. – 26/26 suitable for series/parallel circuit	<b>052</b>	

## Ordering code

01	02	03	04	05	06	07	08	09	10								
<b>MV037</b>	-	<b>A2</b>	-	<b>1S</b>	-	<b>012</b>	-	<b>30</b>	-	<b>B1</b>	-	<b>T</b>	<b>B</b>	<b>B</b>	-	<b>000</b>	

	52 in <sup>3</sup> (852 cc)/rev. – 20/32 requires logic circuit operation as a two speed (alternate combination for 52 cir)	<b>053</b>
--	---	------------

### Displacement Options (continued)

04	57 in <sup>3</sup> (934 cc)/rev. – 20/37 requires logic circuit operation as a two speed	<b>057</b>
	58 in <sup>3</sup> (951 cc)/rev. – 26/32 requires logic circuit operation as a two speed	<b>058</b>
	63 in <sup>3</sup> (1032 cc)/rev. – 26/37 requires logic circuit operation as a two speed	<b>063</b>
	64 in <sup>3</sup> (1049 cc)/rev. – 32/32 suitable for series/parallel circuit	<b>064</b>
	69 in <sup>3</sup> (1131 cc)/rev. – 32/37 requires logic circuit operation as a two speed	<b>069</b>
	74 in <sup>3</sup> (1213 cc)/rev. – 37/37 suitable for series/parallel circuit	<b>074</b>

Motors assembled with largest displacement rotating group closest to front housing

### Shaft Selection

05	Keyed	<b>30</b>
	Splined	<b>31</b>
	Wheel motor with tapered shaft conforming to SAE J501 – Code 62 only	<b>32</b>
	Keyed shaft out front & rear	<b>34</b>
	Shaft with internal key	<b>35</b>
	Shaft with internal spline	<b>36</b>
	Splined shaft out front & rear	<b>40</b>
	Tapered key thrust – Code 61 only	<b>41</b>
	Keyed front with rear shaft – configured to customer specifications	<b>42</b>
	Splined front with rear shaft – configured to customer specifications	<b>43</b>
	Smooth shaft – configured to customer specifications	<b>52</b>
	Hollow shaft with API NC26 (2-3/8") internal flush threads	<b>53</b>
	Hollow shaft with API NC31 (2-7/8") internal flush threads – Code 62 only	<b>63</b>

### Bearing Selection

06	See Code 61 & 62 shaft and bearing combinations for availability (Page 4)	
----	---	--

### Shaft Seal (see page 9)

07	TCN (radial lip seal)	<b>T</b>
	Quad ring	<b>Q</b>
	No shaft seal	<b>0</b>

### Main Body O-rings (see page 8 for seal material specifications)

08	NBR (Buna) – not available in Code 62	<b>B</b>
	FKM (Viton) – Code 61 optional, Code 62 only	<b>V</b>

### Pedestal O-rings (see page 8 for seal material specifications)

09	NBR (Buna) – Code 61 standard, not available in Code 62	<b>B</b>
	FKM (Viton) – Code 61 optional, not available in Code 62	<b>V</b>
	Disogrin – Code 62 only	<b>D</b>

### Special Index Number

10	Standard design – special features are designated with a three-digit code (consult factory)	<b>000</b>
----	---	------------

## Ordering code

### Shaft and bearing combinations

#### Code 61

	30	31	34	35	36	40	41	42	43	52	53
B1	●	●	●	●	●	●	—	●	●	—	—
B2	—	—	—	—	—	—	●	—	—	—	—
B3	○	○	—	—	—	—	—	—	—	●	—
T1	—	—	—	—	—	—	—	—	—	—	●

#### Code 62

	30	31	32	34	35	36	40	42	43	52	53	63
T1	●	●	●	●	—	—	●	●	●	●	—	—
T2	—	—	—	—	●	●	—	—	—	—	—	—
T4	—	—	—	—	—	—	—	—	—	—	●	—
T5	—	—	—	—	—	—	—	—	—	—	—	●

● = available    ○ = upon request    — = not available

**Note:** Other shaft and bearing combinations may be available. Consult factory.

### Weights

Type of motor	lbs.	kg
Code 61, 2 port	100	46
Code 61, 2 port, 34 shaft	102	47
Code 61, 4 port, 35 & 36 shaft	92	42
Code 61, 2 port, 41 shaft	114	52
Code 61, 2 port, double stack	135	61
Code 61, 4 port	172	78
Code 62, 2 port	117	53
Code 62, 2 port, 32 shaft	115	52
Code 62, 2 port, 53 shaft	128	58
Code 62, 2 port, double stack	145	66
Code 62, 4 port	182	83
Code 62, 4 port, 53 shaft	200	91
Code 62, 4 port, 63 shaft	280	127

**Technical data**

The MV037 series motors are hydraulically balanced internally and therefore no significant radial loads are induced on the motor bearings which contribute to long service life. The motor can be configured with various bearing options to accommodate external radial and axial loading. This data sheet details standard motors (see Figure 1); technically feasible, custom solutions may be offered. Please consult factory.

Oil supply lines are connected to ports A and B on 2-port and double stack motor configurations and to A1, A2, B1 and B2 on 4-port configurations. Case drain lines can be installed on the C1 port. Reference motor unit drawings on page 6 for additional case line locations and Case Drain section on page 40 for details. Using the “A” port as

the inlet will provide clockwise shaft rotation as seen from the front of the shaft. Using the “B” port will provide counter-clockwise shaft rotation also seen from the front of the shaft (see Figure 2 & Figure 3). The 4-port configuration has the front housing port designated “A1,” the center housing ports have been designated “A2” and “B1,” and the rear housing port is designated as “B2.” This configuration can be used as a two speed motor with appropriate external valving. Like the motor with the single rotating group when inlet flow is provided to the “A1 and A2” ports the motor shaft rotation will be clockwise as seen from the front of the shaft, and when inlet flow is provided to the “B1 and B2” ports the motor shaft rotation will be counter-clockwise as seen from the front of the shaft (see Figure 4).

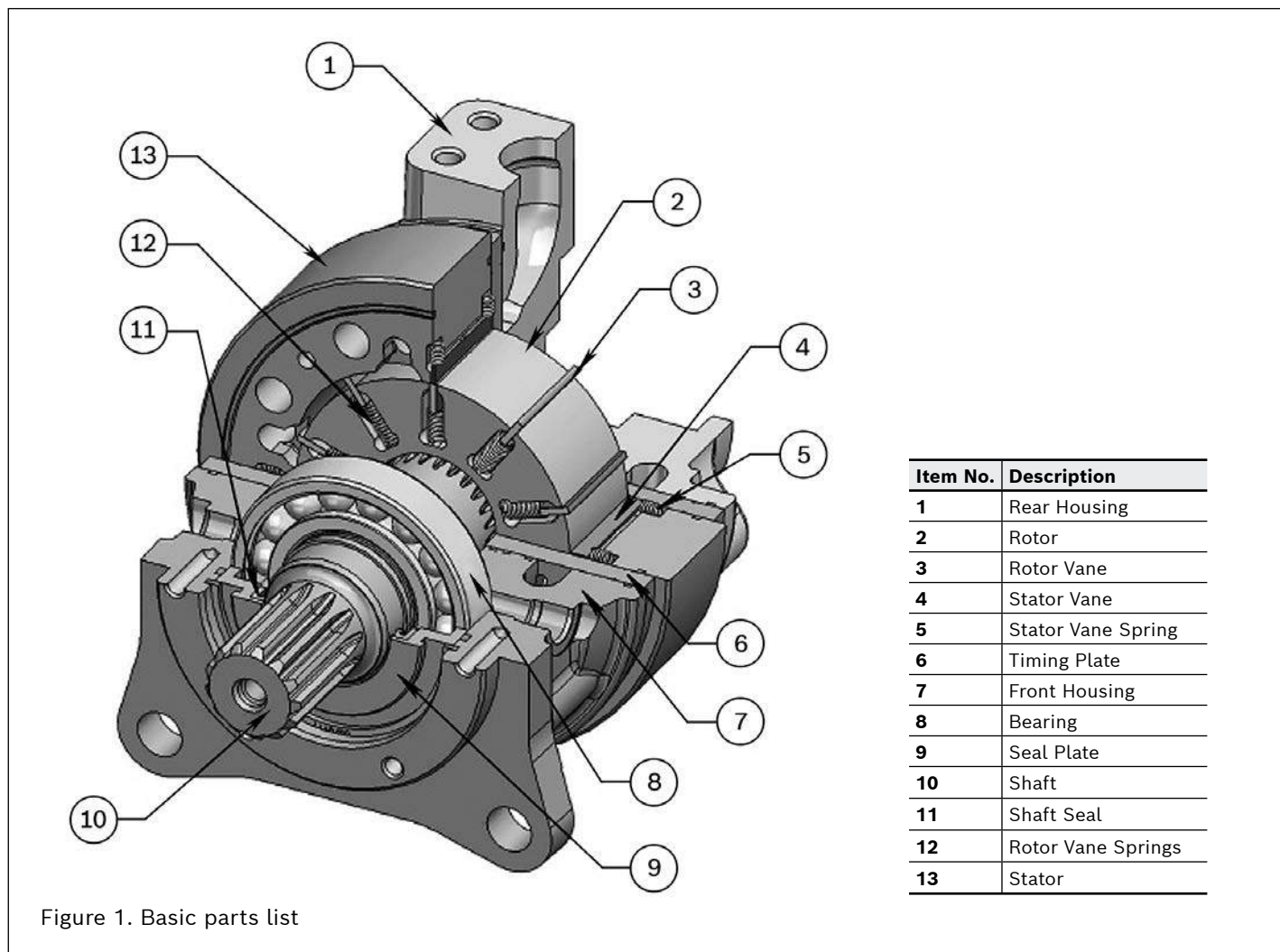

Item No.	Description
1	Rear Housing
2	Rotor
3	Rotor Vane
4	Stator Vane
5	Stator Vane Spring
6	Timing Plate
7	Front Housing
8	Bearing
9	Seal Plate
10	Shaft
11	Shaft Seal
12	Rotor Vane Springs
13	Stator

Figure 1. Basic parts list

Technical data

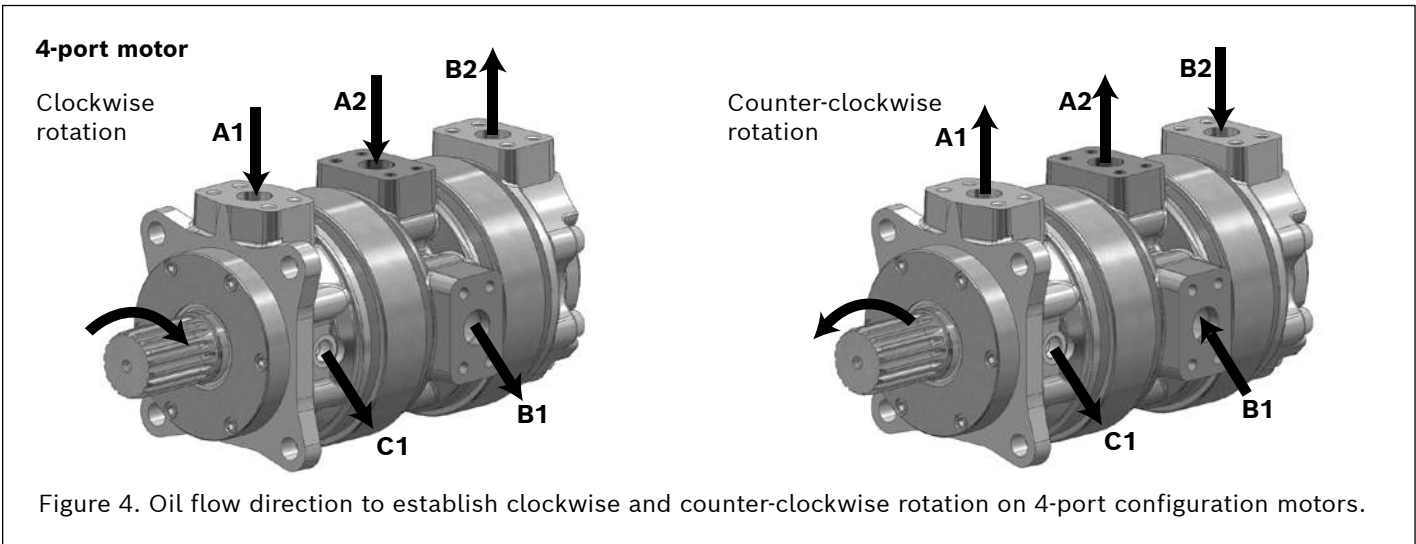
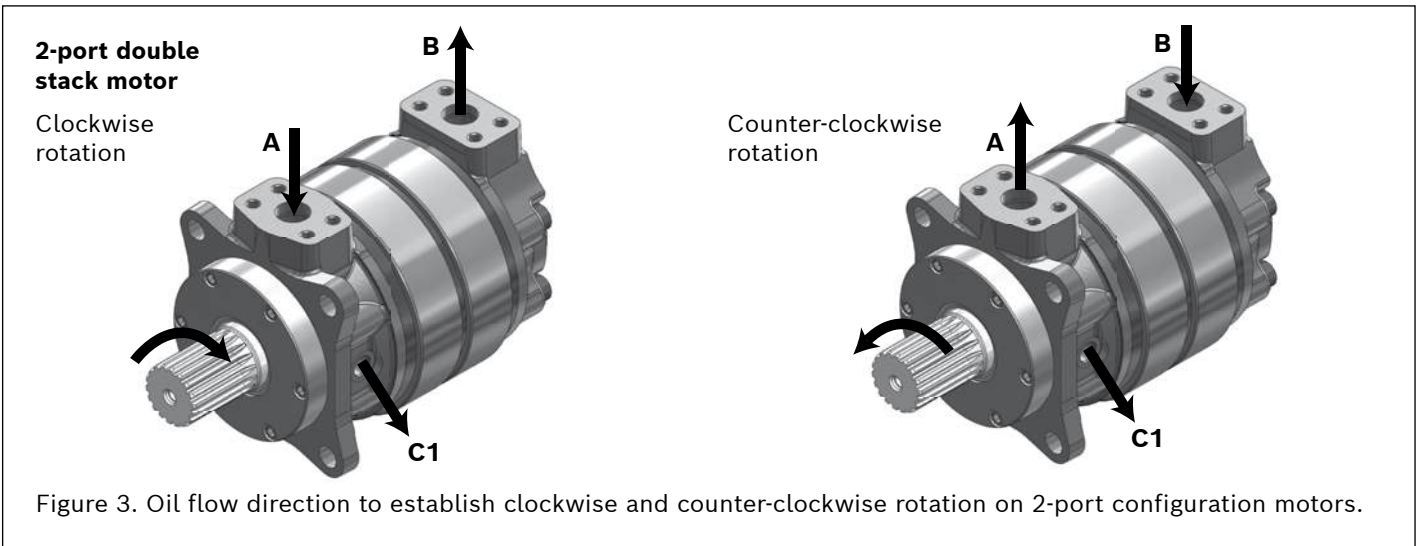
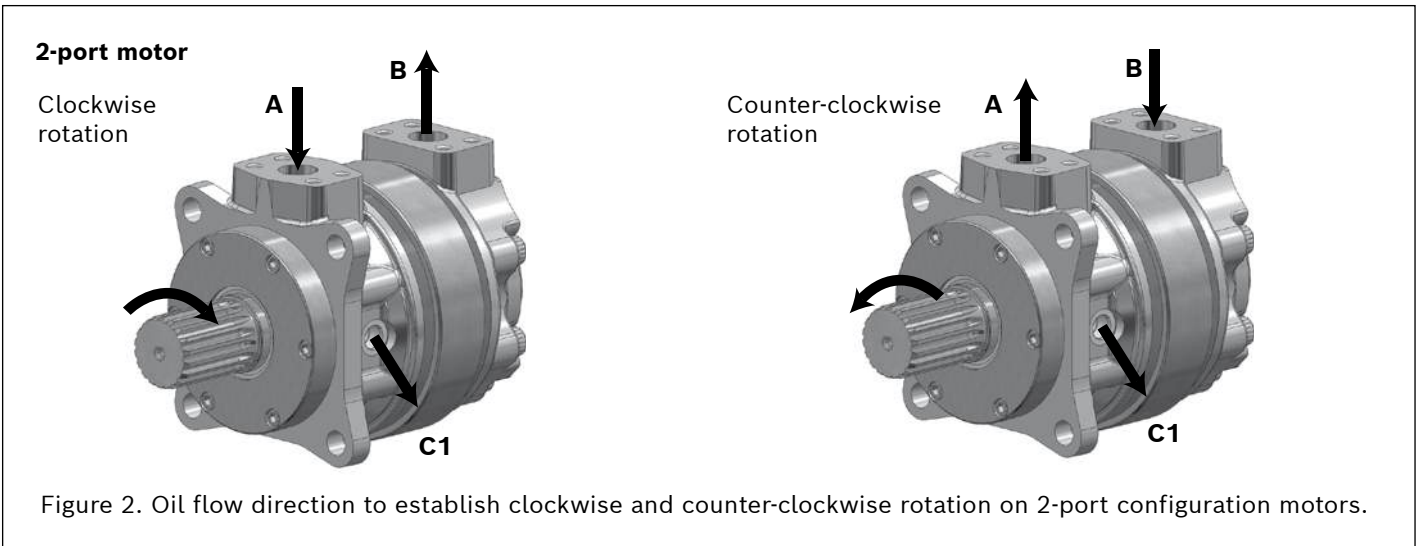

## Technical Data

### Motor specifications

Standard Series Code 61	Displacement		Pressure				Speed		Torque @ 3000 psid (207 bar)*	
	(in <sup>3</sup> /rev)	(cm <sup>3</sup> /rev)	Continuous		Intermittent		Continuous	Intermittent	Continuous	
			(psid)	(bar)	(psid)	(bar)	(rpm)	(rpm)	(lb-ft)	(Nm)
MV037-A,C	12	197	3000	207	3500	241	1000	1200	410	556
	16	262					1000	1200	553	750
	20	328					1000	1200	722	979
	26	426					800	1000	920	1247
	32	524					700	950	1143	1550
	37	606					600	800	1315	1783

High Performance Series Code 62	Displacement		Pressure				Speed		Torque @ 4500 psid (310 bar)*	
	(in <sup>3</sup> /rev)	(cm <sup>3</sup> /rev)	Continuous		Intermittent		Continuous	Intermittent	Continuous	
			(psid)	(bar)	(psid)	(bar)	(rpm)	(rpm)	(lb-ft)	(Nm)
MV037-D	12	197	4500	310	5000	345	1000	1200	637	864
	16	262					1000	1200	851	1154
	20	328					1000	1200	1104	1497
	26	426					800	1000	1399	1897
	32	524					700	950	1735	2352
	37	606					600	800	2007	2721

\* Torque values are average performance data measured at maximum speeds with 100 SUS (20cSt) and standard rotating group.

#### Note:

1. When considering 2-port double stack or 4-port motors, any two displacements can be combined. The resultant torque is the sum of the 2 displacements.
2. Maximum speed is limited by the highest displacement selected.
3. Intermittent duty cycle is six (6) seconds per minute.
4. Higher speeds or pressure may be permissible under certain conditions. Consult factory.

## Technical data

### Choice of hydraulic fluid

Bosch Rexroth Rineer high torque vane motors are primarily designed to operate on conventional petroleum based hydraulic oils. The hydraulic oil can be chosen in consultation with the oil supplier or your local sales office, bearing the following requirements in mind:

### General

The oil shall have FZG (90) fail stage minimum 11 described in IP 334 (DIN 51354). The oil must also contain inhibitors to prevent oxidation, corrosion and foaming. The viscosity of mineral oil is highly dependent on the temperature. The final choice of oil must depend on the operating temperature that can be expected at the motor or that has been established in the system and not in the hydraulic tank.

High temperatures in the system greatly reduce the service life of oil and rubber seals, as well as resulting in low viscosity, which in turn provides poor lubrication. Content of water shall be less than 0.1%.

Oil used in the system should be filtered by a minimum of 25 micron filter.

### Fluid Cleanliness

System Pressure	
< 3000 psi / 207 bar	> = 3000 psi / 207 bar
19/17/14*	18/16/13

\* ISO 4406 Standard

### Viscosity

Minimum Operating Viscosity	100 SSU / 20 cSt
Maximum Operating Viscosity	250 SSU / 54 cSt

Minimum operating viscosities must be met even at maximum temperature. Operating below 20 cSt will result in reduced life expectancy.

Maximum fluid temperature should not exceed 180 °F (82 °C).

Please consult with a Bosch Rexroth Rineer Applications Engineer when using fire resistant fluid, water glycols, biodegradable fluids, or viscosities outside above recommendations.

### Seals

#### Buna N (NBR)

Temperature Range:

–65 °F to +250 °F (–54 °C to +121 °C)

Buna N is a copolymer of butadiene and acrylonitrile with excellent compatibility with petroleum products. For exposure in low temperatures it is necessary to sacrifice some high temperature resistance. The product is superior in compression set, cold flow, tear, and abrasion resistance. Inferior in resistance to ozone, sunlight or weather. It is generally recommended for petroleum, water, diester, and water-glycol. Not recommended for use with halogenated hydrocarbons, phosphate ester, ketones, acids, and brake fluids.

#### Fluorocarbon (FKM) (Viton)

Temperature Range:

–20 °F to +350 °F (–29 °C to +177 °C)

Viton is a linear copolymer of vinylidene fluoride and hexafluoro propylene which offers the widest temperature range and chemical resistance. The product is compatible and recommended for use with most fluids and gases such as petroleum, silicate ester, diester, halogenated hydrocarbons, and most phosphate esters. Viton has very good ozone, weather and aging resistance. It is not recommended for ketones, glycol based brake fluids, superheated steam, formic and acetic acids.

#### Disogrin (TODI/Polyurethane)

Temperature Range:

–54 °F to +230 °F (–48 °C to +110 °C)

Disogrin is a high performance polyurethane. This compound is primarily used on O-rings for heavy duty applications and possesses extremely high mechanical properties, offering outstanding resistance to abrasion, tear and extrusion over a large range of temperatures. It has high temperature stability resulting in very low compression set required for sealing ensuring maximum service life. It is suitable for use with petroleum based fluids and some



## Technical data

biodegradable (synthetic and natural Ester) fluids. Bosch Rexroth Rineer offers two types of rotary seals, namely a lip seal and quad ring seal designs in both NBR and FKM materials. Radial lip seals accommodate external radial loads imposed on the shaft and higher speeds to a greater degree than quad seal designs. Both designs will accommodate axial loading on the shaft.

Heat failure of the material is the most common failure mode for a rotary seal. Reducing the friction at the shaft / seal interface is the most effective method of reducing heat build up on the seal. The higher the pressure to be sealed combined with high shaft speeds results in increased friction (heat buildup), decreasing seal life. Properly performing rotary seals offer unique challenges. Our seals operate with an oil film under the seal / shaft contact area that separates the two surfaces reducing surface wear and providing cooling to the contact area. Slippage oil which by-passes the vanes, rotor and timing plate interface accumulates in the case and lubricates the

bearings and seals.

### Shaft seal options

Seal Type	Maximum Case Pressure	External Loading
Radial Lip Seal	35 psig (2.4 bar)	Radial / Axial
Quad Seal	100 psig (6.9 bar)	Low Radial / Axial
No Shaft Seal	500 psig (35 bar)	N/A

When the motor is mated to a gearbox, bearing box, or overhung load adapter, it is possible to specify the motor to have no shaft seal which would allow motor case flow to flush the companion component. In this instance, the driven component must have a case connection to allow flow back to tank at a pressure low enough for the rating of its shaft seal.

## Technical data

### Selecting / Sizing a Motor

Motor selection is dependent on the application and generally the required horsepower, motor speed range, and available supply pressure are to be defined. Alternatively desired output torque and speed for a given application can be used. Motor speed (shaft speed) is a function of flow delivered to the motor and displacement. Torque output is a function of differential pressure and motor displacement. The charts illustrated are based on actual performance data and account for losses in a given motor.

For example:

An application requirement is 50 hp (37.28 kW) at 200 rpm with an available supply pressure of 3200 psi (221 bar) and a return line pressure of 200 psi (14 bar). The pressure differential is 3000 psi (207 bar).

#### Calculations:

Theoretical torque (ideal no losses):

#### Metric:

$$T = \frac{P \times 9549.09}{n} = \frac{37.28 \times 9549.09}{200} = 1780 \text{ N-m}$$

#### U.S.:

$$T = \frac{P \times 5252}{n} = \frac{50 \times 5252}{200} = 1313 \text{ lb-ft}$$

Theoretical displacement (ideal no losses):  
for condition  $T = 1780 \text{ N-m}$  ( $T = 1313 \text{ lb-ft}$ )

#### Metric:

$$d = \frac{T \times 62.81}{p} = \frac{1780 \times 62.81}{207} = \sim 540 \text{ cc}$$

#### U.S.:

$$d = \frac{T \times 75.4}{p} = \frac{1313 \times 75.4}{3000} = 33 \text{ cir}$$

Referencing the chart “Torque 37 cir (606 cc)”

A 37 cir (606 cc) displacement motor at a pressure 3000 psid (207 bar) will develop torque of approximately 1313 lb-ft (1780 N-m).

Referencing the chart “Total Required Flow 37 cir (606 cc)”

A 37 cir (606 cc) displacement motor at a pressure of 3000 psid (207 bar) operating at 200 rpm will require a total flow of approximately 36 gpm (136.3 lpm).

### Nomenclature

Symbol	Measurable Quantity	U.S.	Metric
$d$	Displacement	cir or $\frac{in^3}{rev}$	cc or $\frac{cm^3}{rev}$
$Q$	Flow	gpm or $\frac{gal}{min}$	lpm or $\frac{liters}{min}$
$n$	Shaft Speed	rpm or $\frac{revolutions}{min}$	rpm or $\frac{revolutions}{min}$
$P$	Power	hp	kW
$\Delta p$	Differential pressure	psid	bar
$T$	Torque	lb-ft	N-m

### Calculation Fundamentals

U.S.	Metric
$T = \frac{P \times 5252}{n}$	$T = \frac{P \times 9549.09}{n}$
$T = \frac{d \times \Delta p}{75.4}$	$T = \frac{d \times \Delta p}{62.81}$
$P_{shaft} = \frac{T \times n}{5252}$	$P_{shaft} = \frac{T \times n}{9549.09}$
$P_{shaft} = \frac{Q \times \Delta p}{1714}$	$P_{shaft} = \frac{Q \times \Delta p}{599.29}$
$Q = \frac{d \times n}{231}$	$Q = \frac{d \times n}{1000}$
$n = \frac{P \times 5252}{T}$	$n = \frac{P \times 9549.09}{T}$
$d = \frac{T \times 75.4}{\Delta p}$	$d = \frac{T \times 62.81}{\Delta p}$

### Unit Conversions

Quantity	Symbol	Metric	Convert	U.S.
Torque	$T$	N-m	÷ 1.356	lb-ft
Power	$P$	kW	x 1.341	hp
Displacement	$d$	cm <sup>3</sup> /rev	÷ 16.385	in <sup>3</sup> /rev
Flow Rate	$Q$	lpm	÷ 3.78	gpm
Rotational Speed	$n$	rpm	=	rpm
Pressure	$p$	bar	x 14.504	psi

**Technical data**

**Flow & output torque – 12 cir**

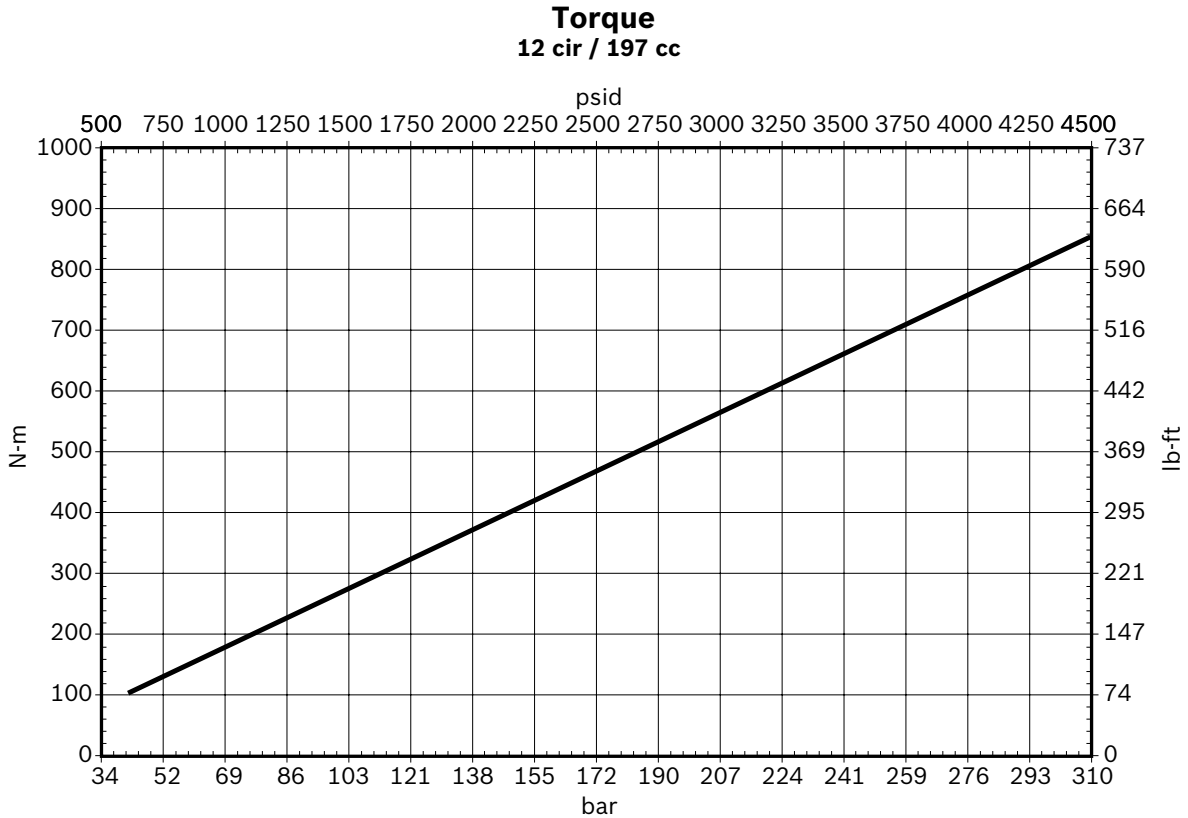
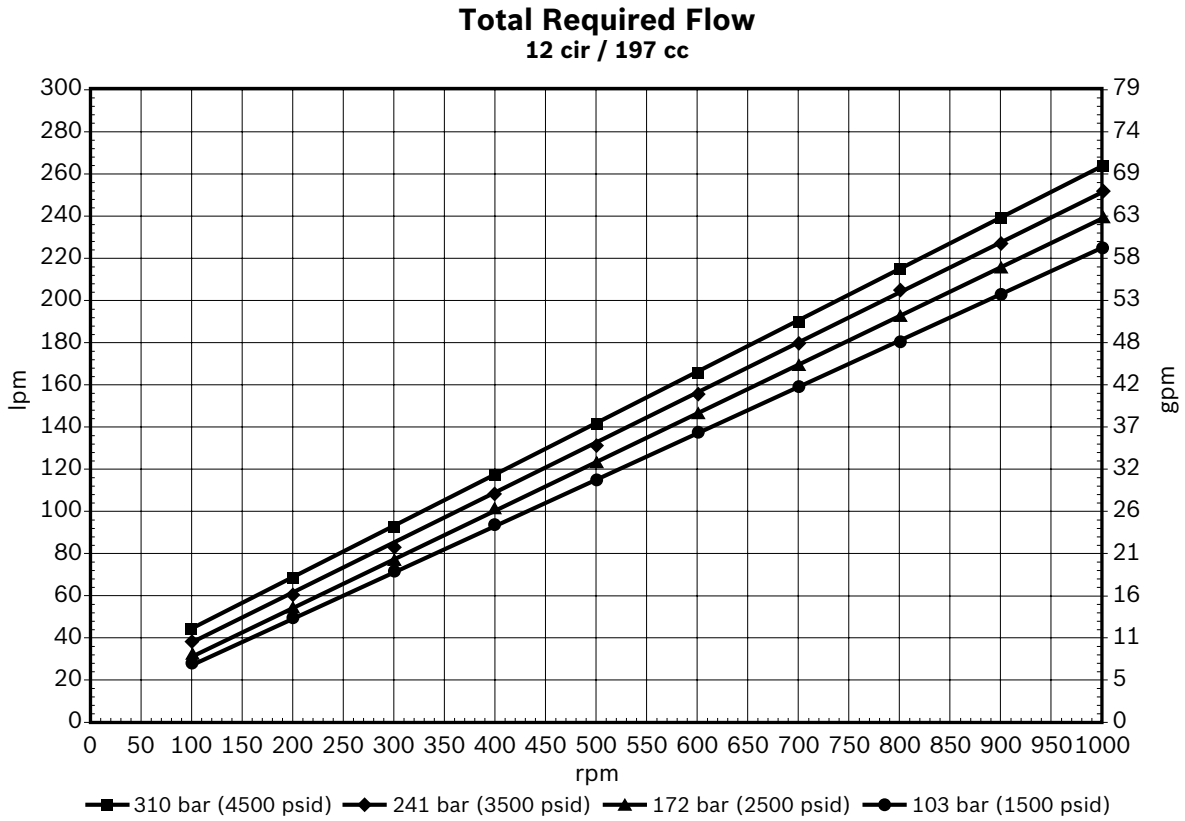

Technical data

Flow & output torque – 16 cir

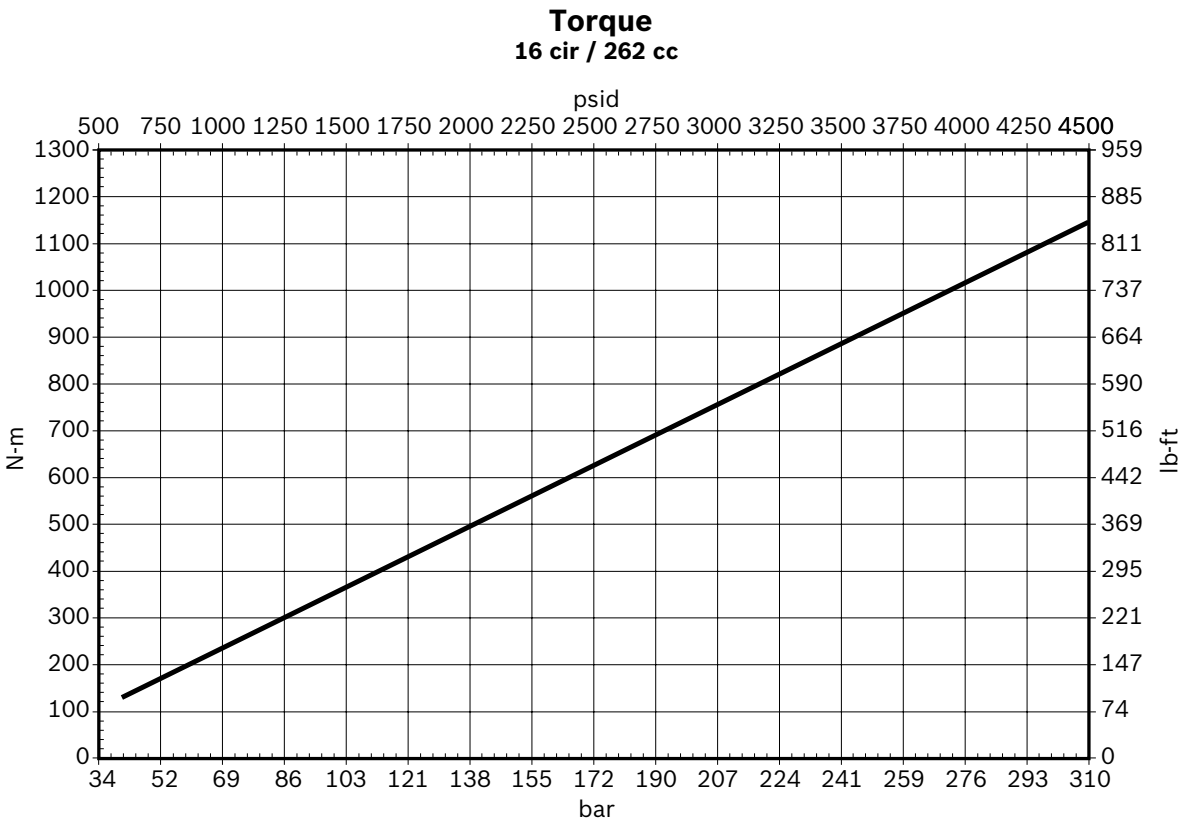
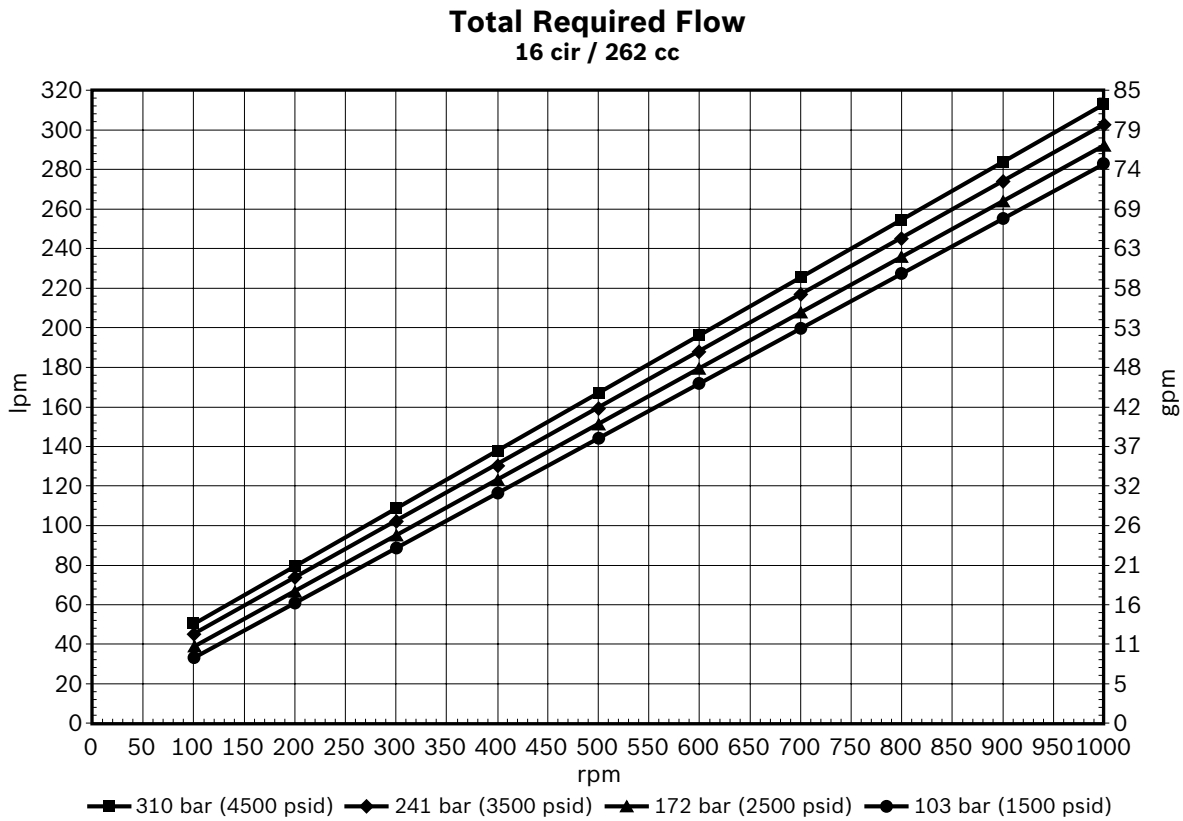

**Technical data**

**Flow & output torque – 20 cir**

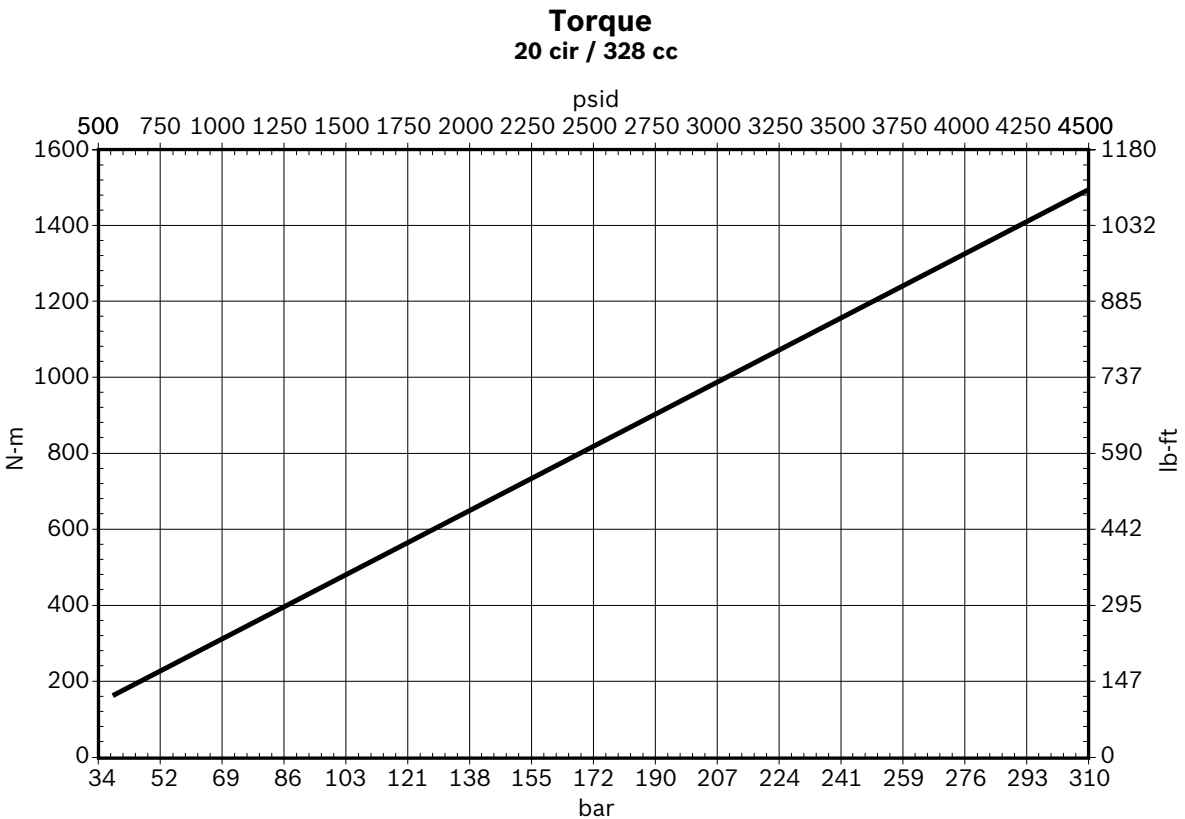
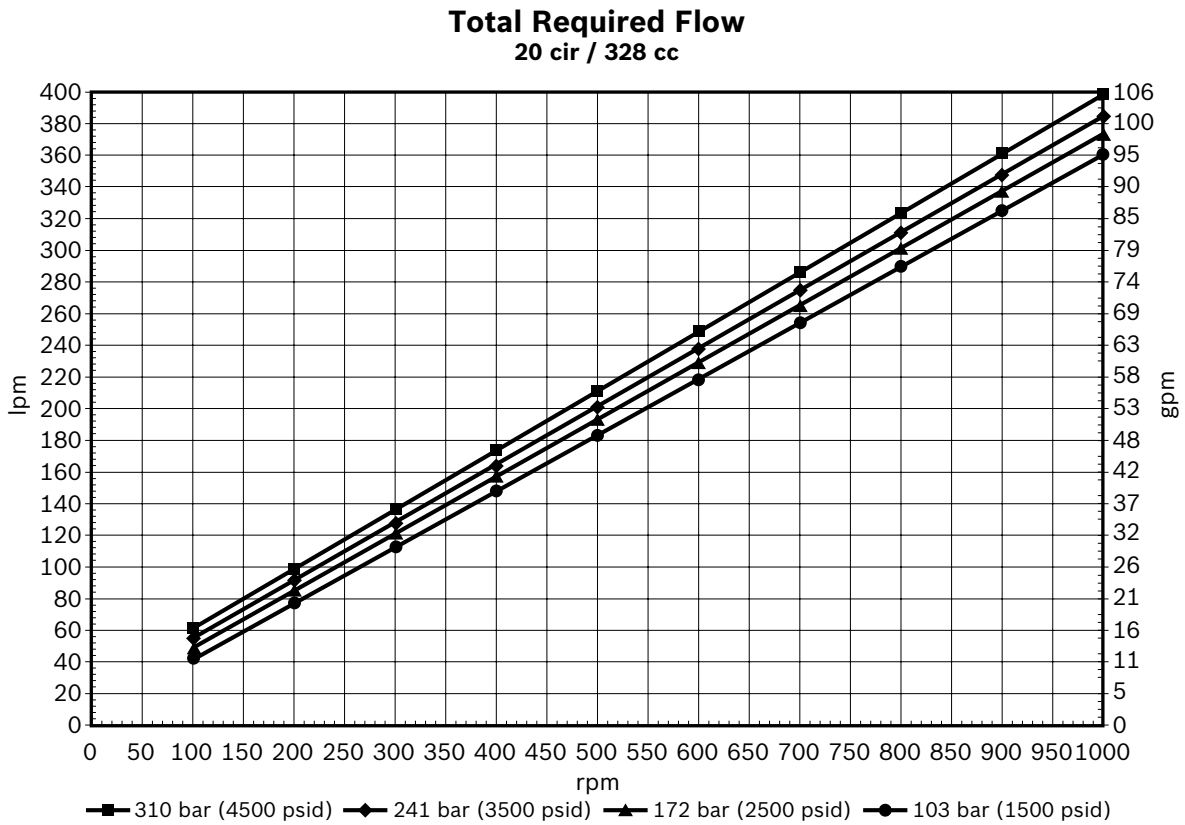

Technical data

Flow & output torque – 26 cir

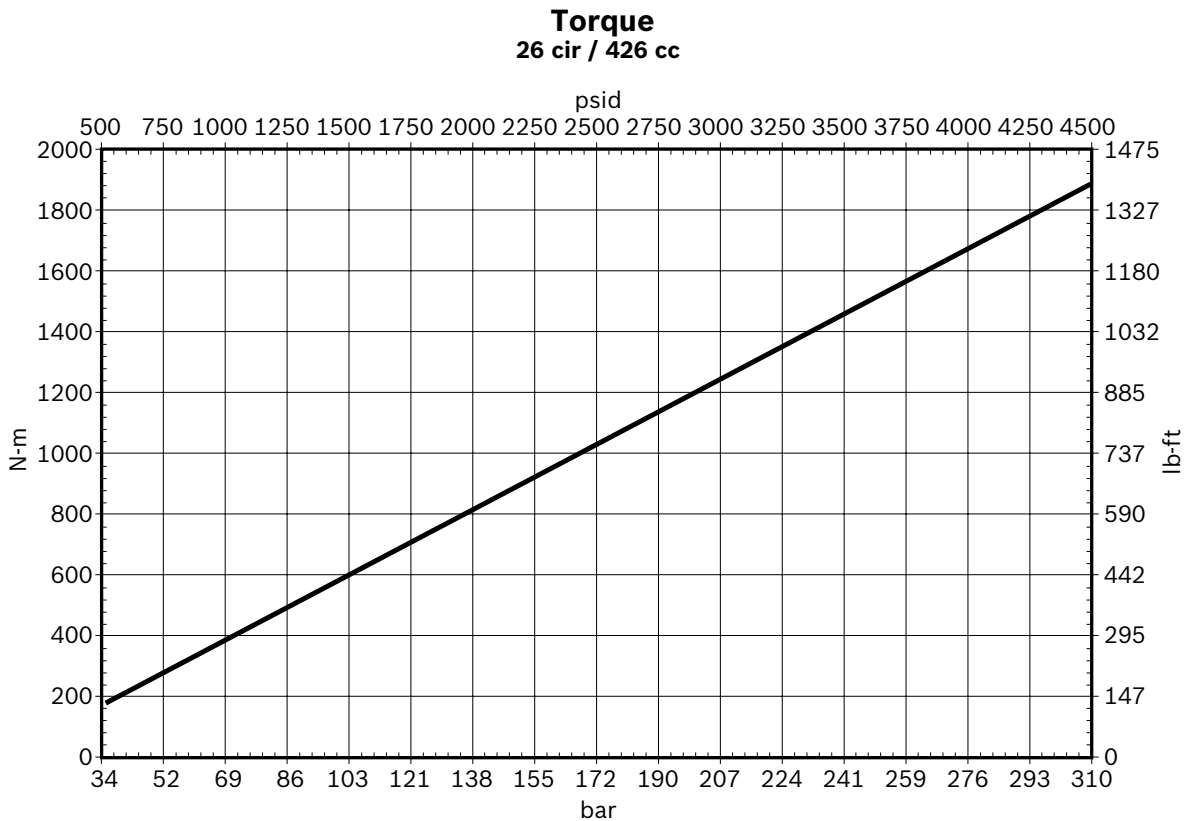
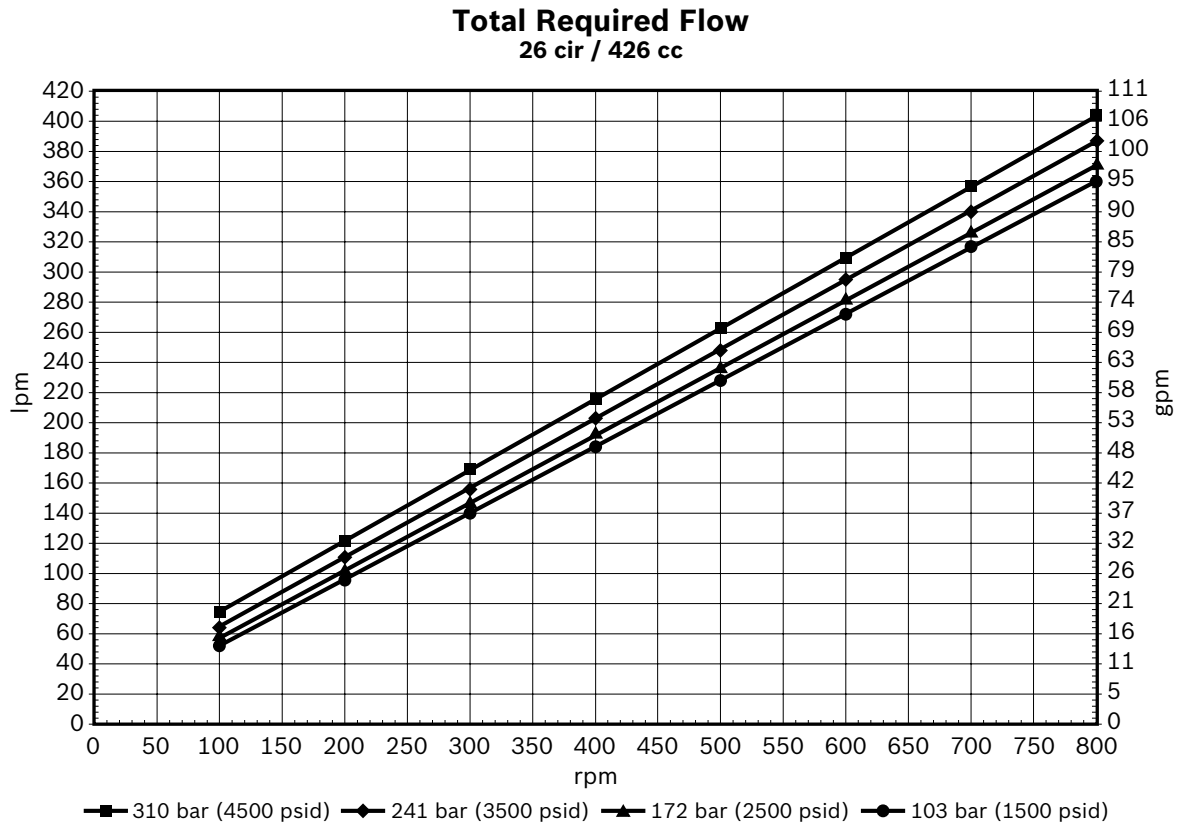

**Technical data**

**Flow & output torque – 32 cir**

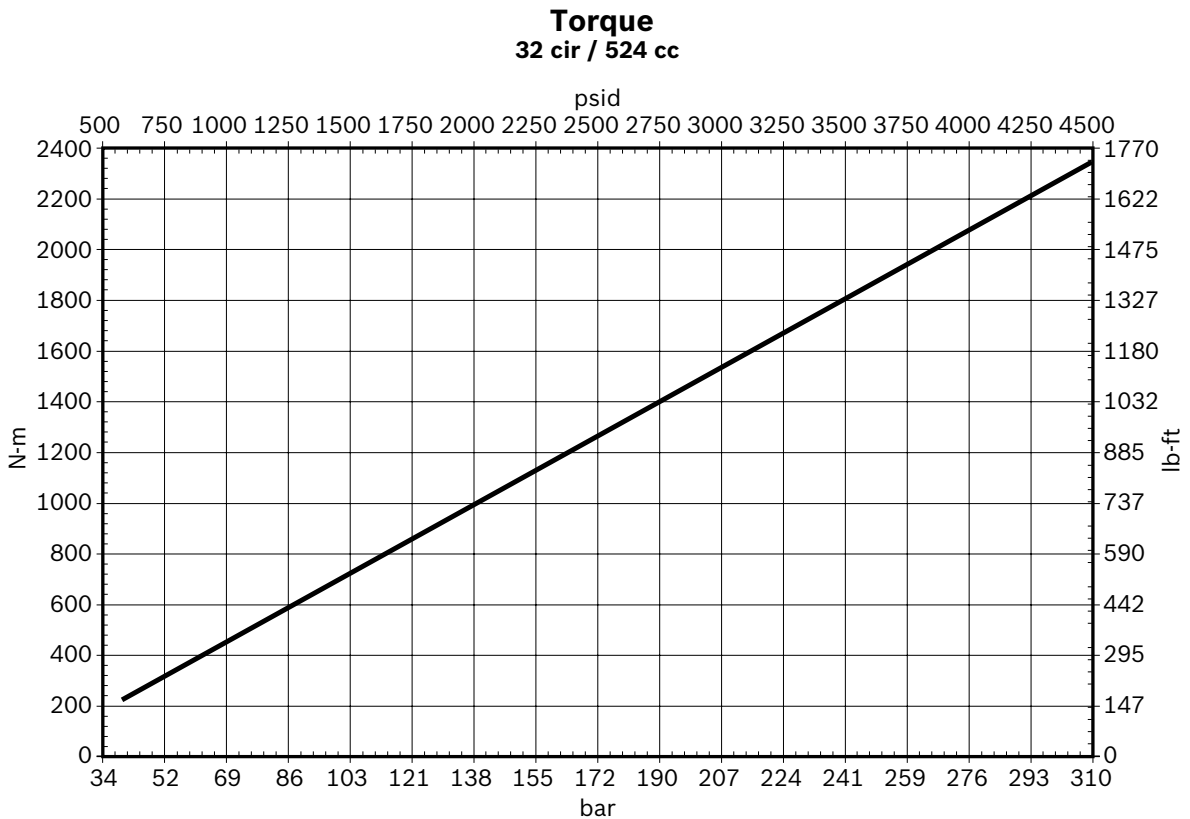
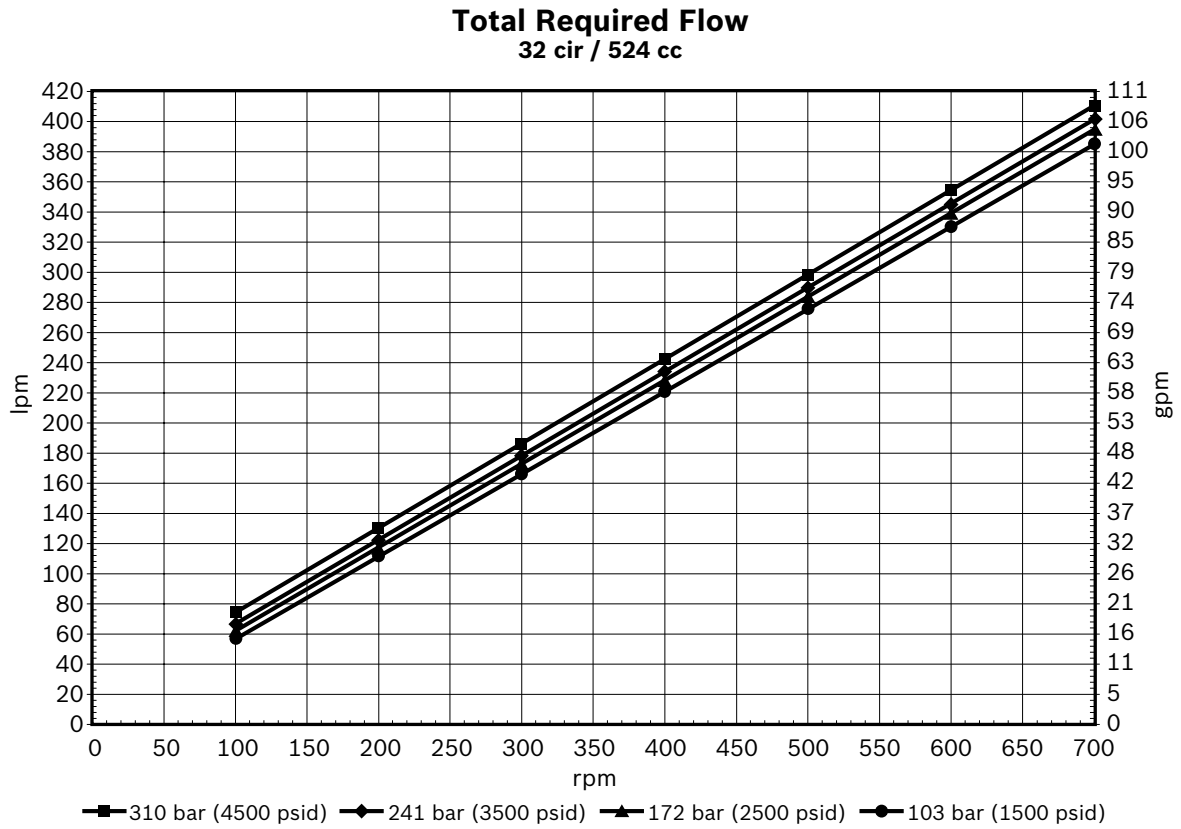

Technical data

Flow & output torque – 37 cir

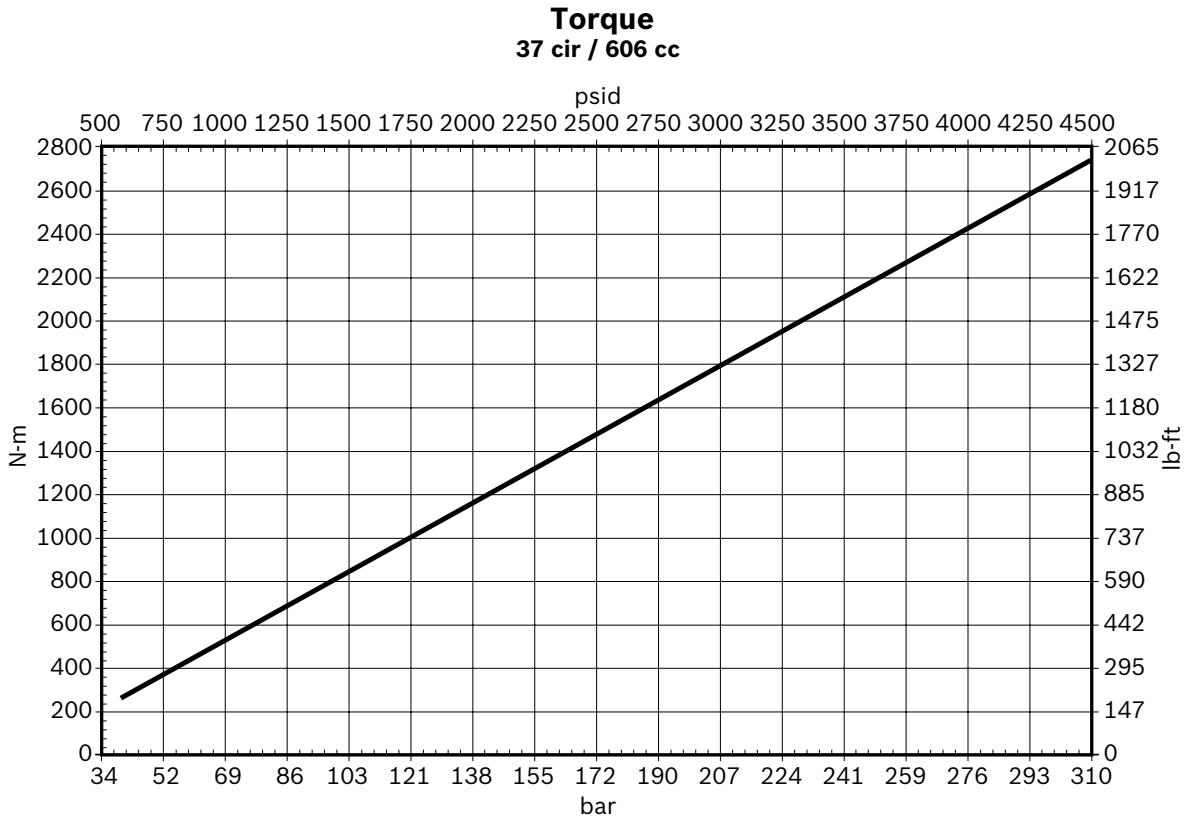
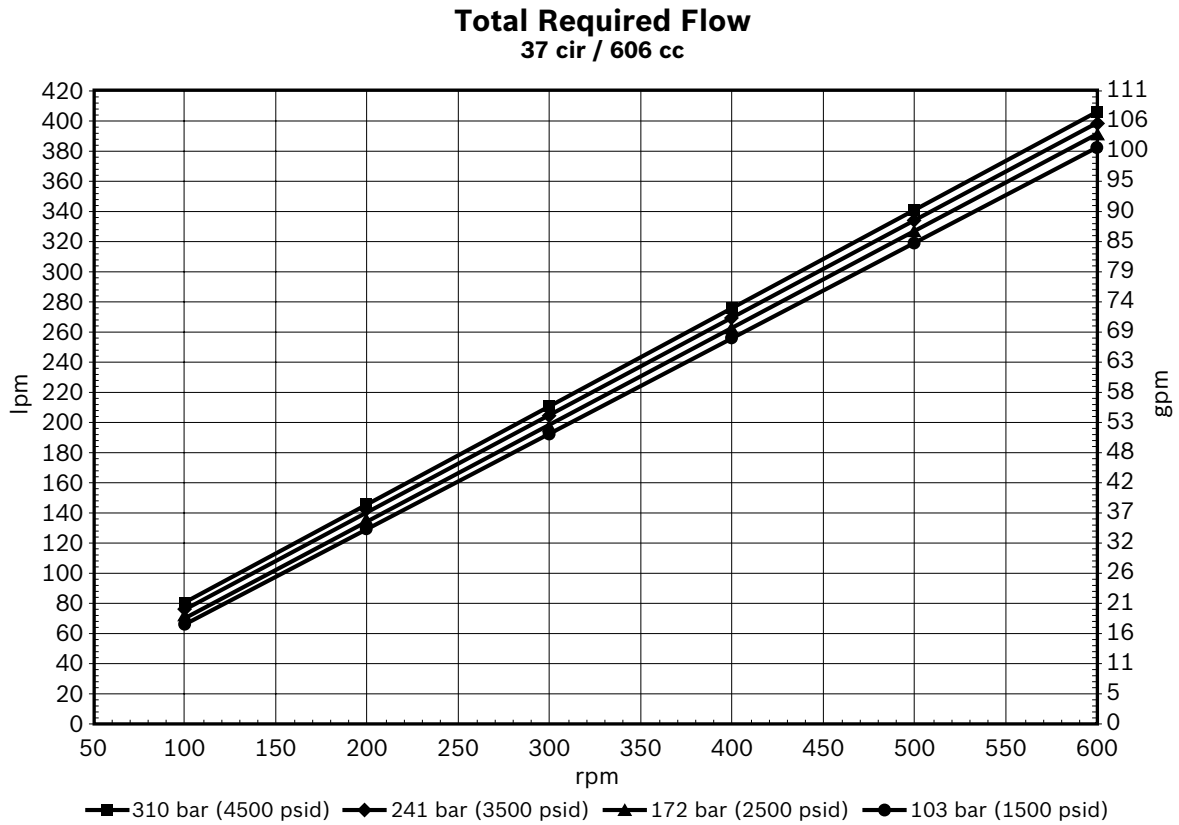



**Technical data**

**Bearing data – Code 61 standard motor (B1 bearing)**

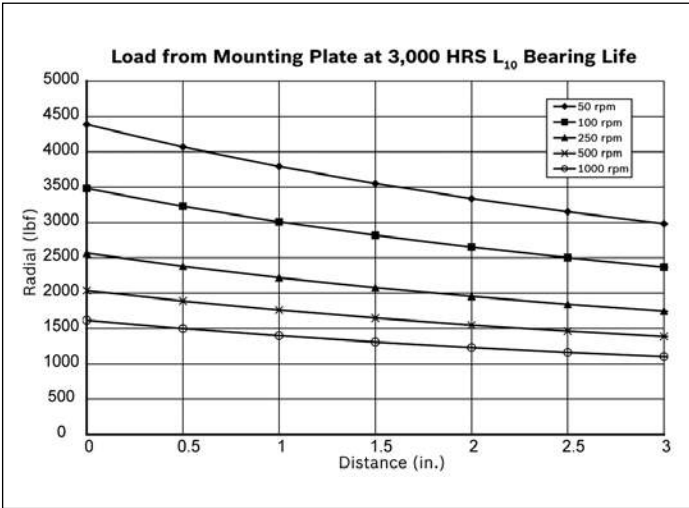
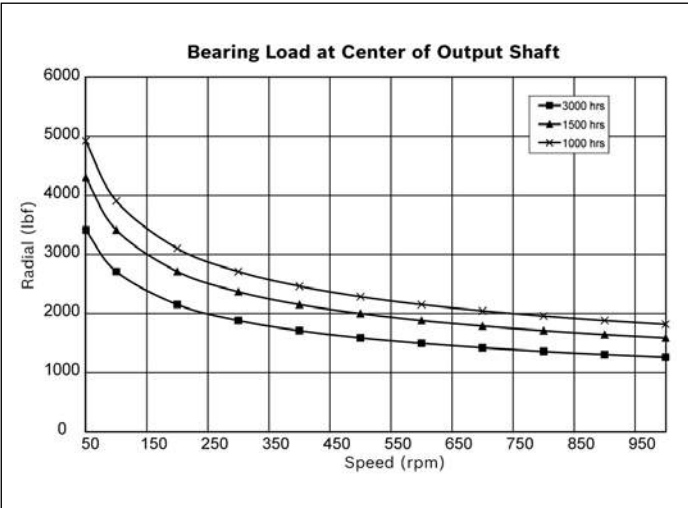
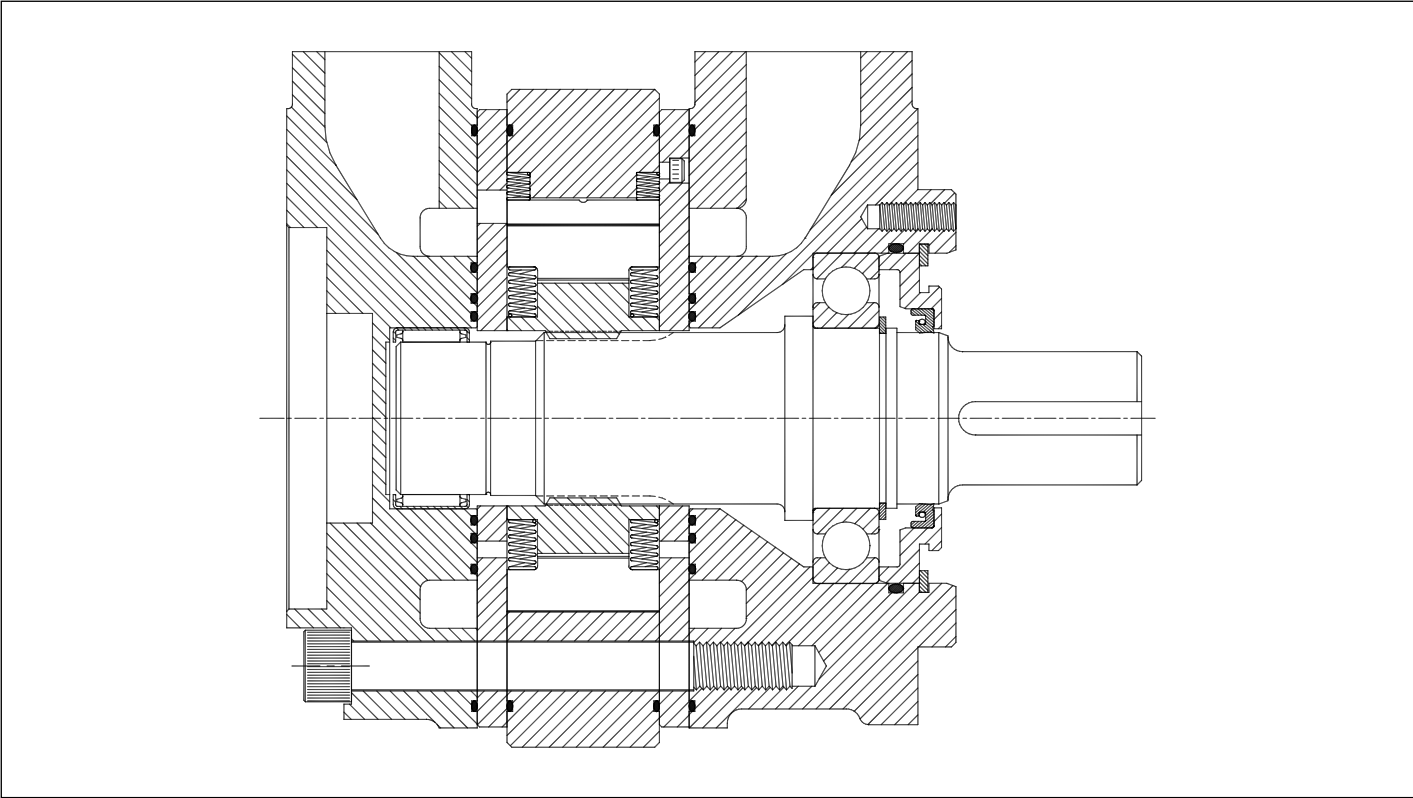

**Bearing loading**

The bearings in the 37 Series can accept radial load per the radial capacity charts above. Thrust loading is not recommended for the standard motor. For thrust-type applications, see the thrust capable motor bearing chart.

Technical data

Bearing data – Code 61 standard motor (B2 bearing)

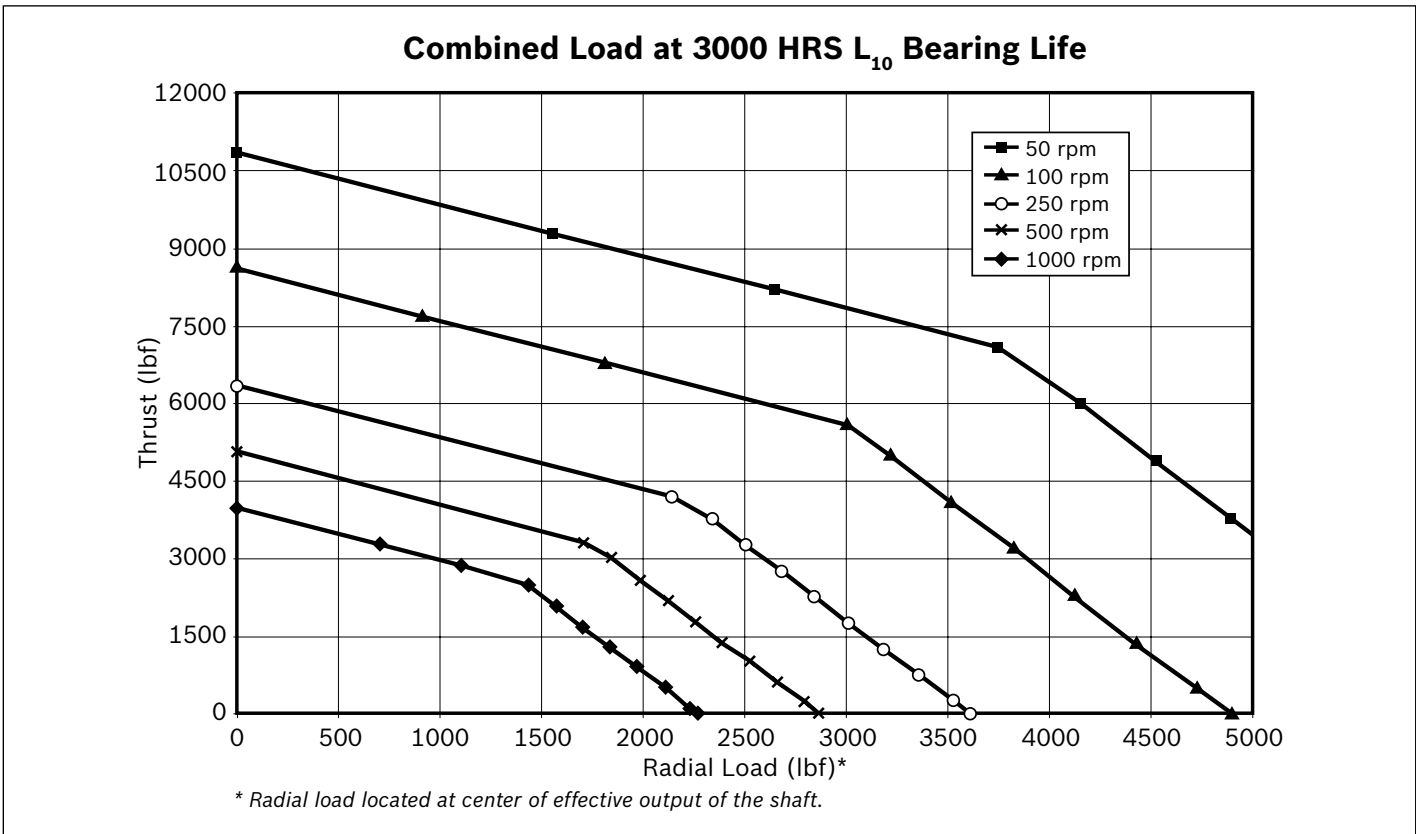
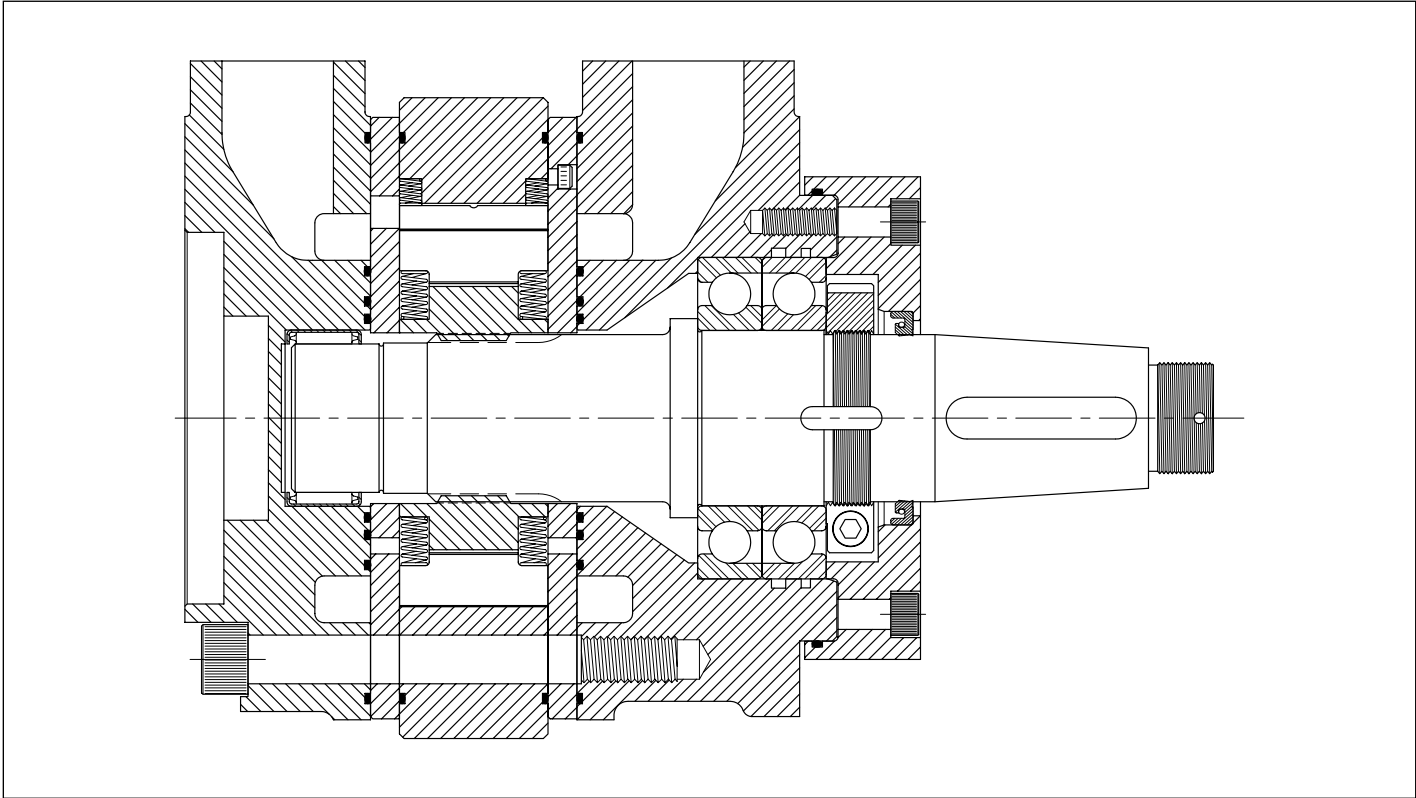

**Technical data**

**Bearing data – Code 61 standard motor (B3 bearing)**

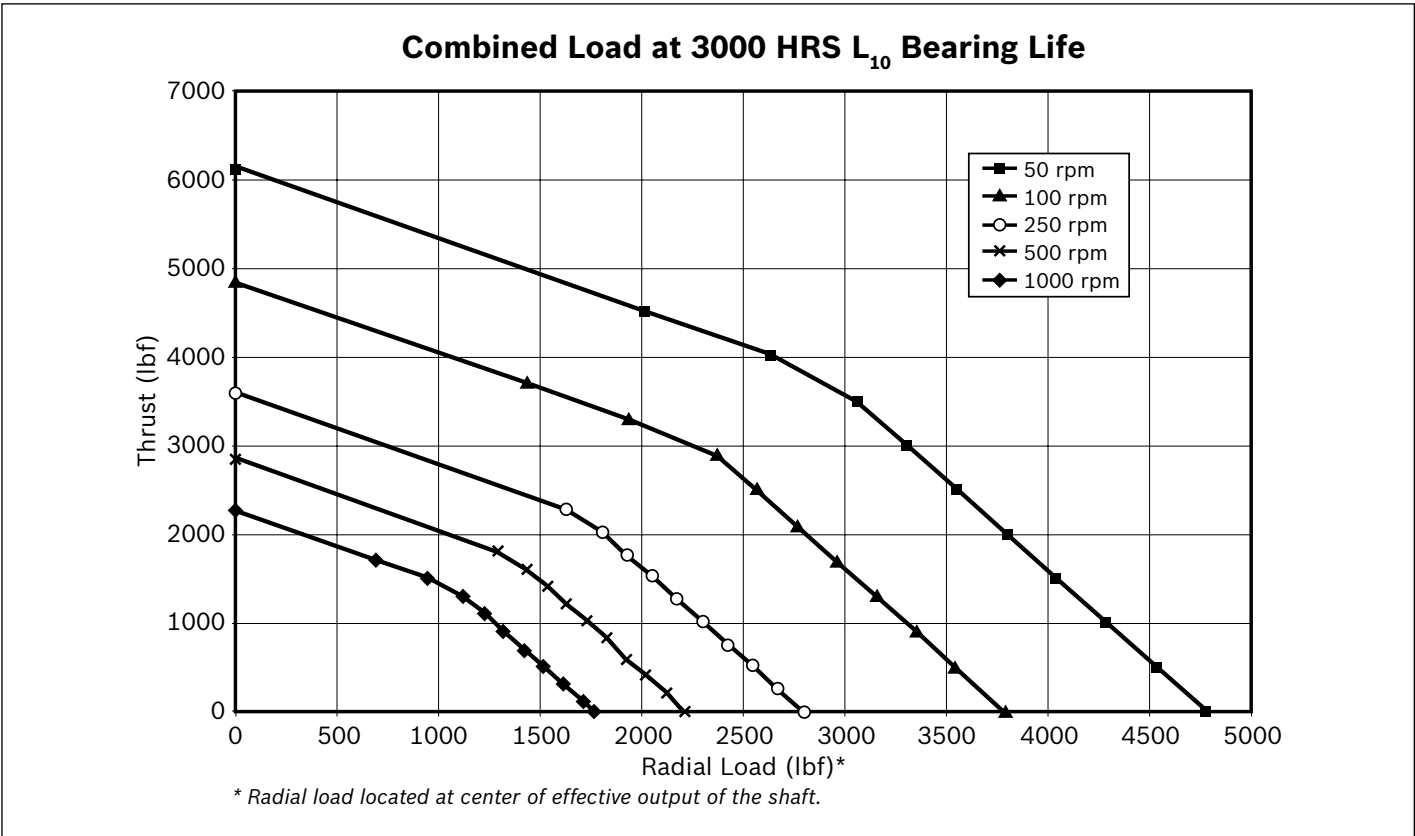
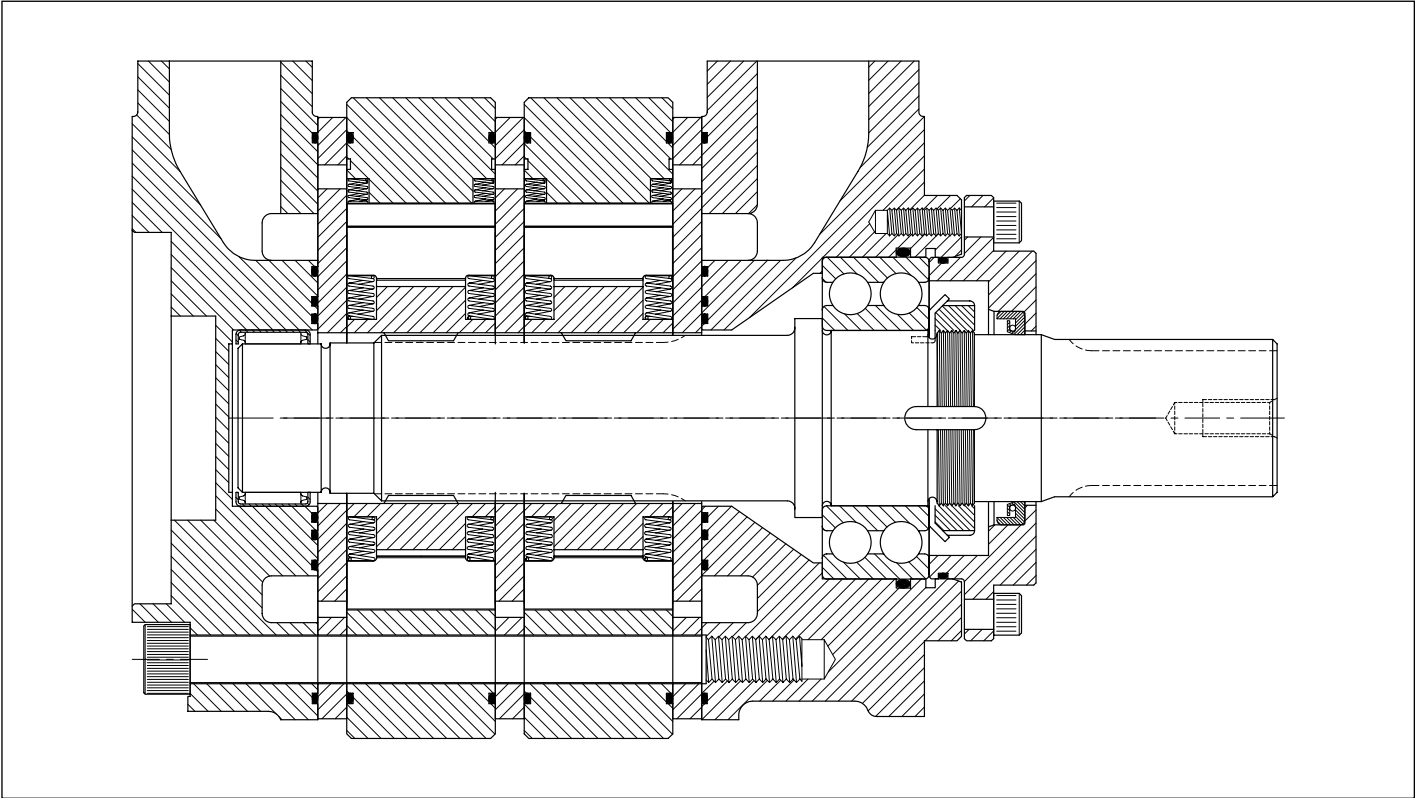

**Technical data**

**Bearing data – Code 61 (T1 bearing)**

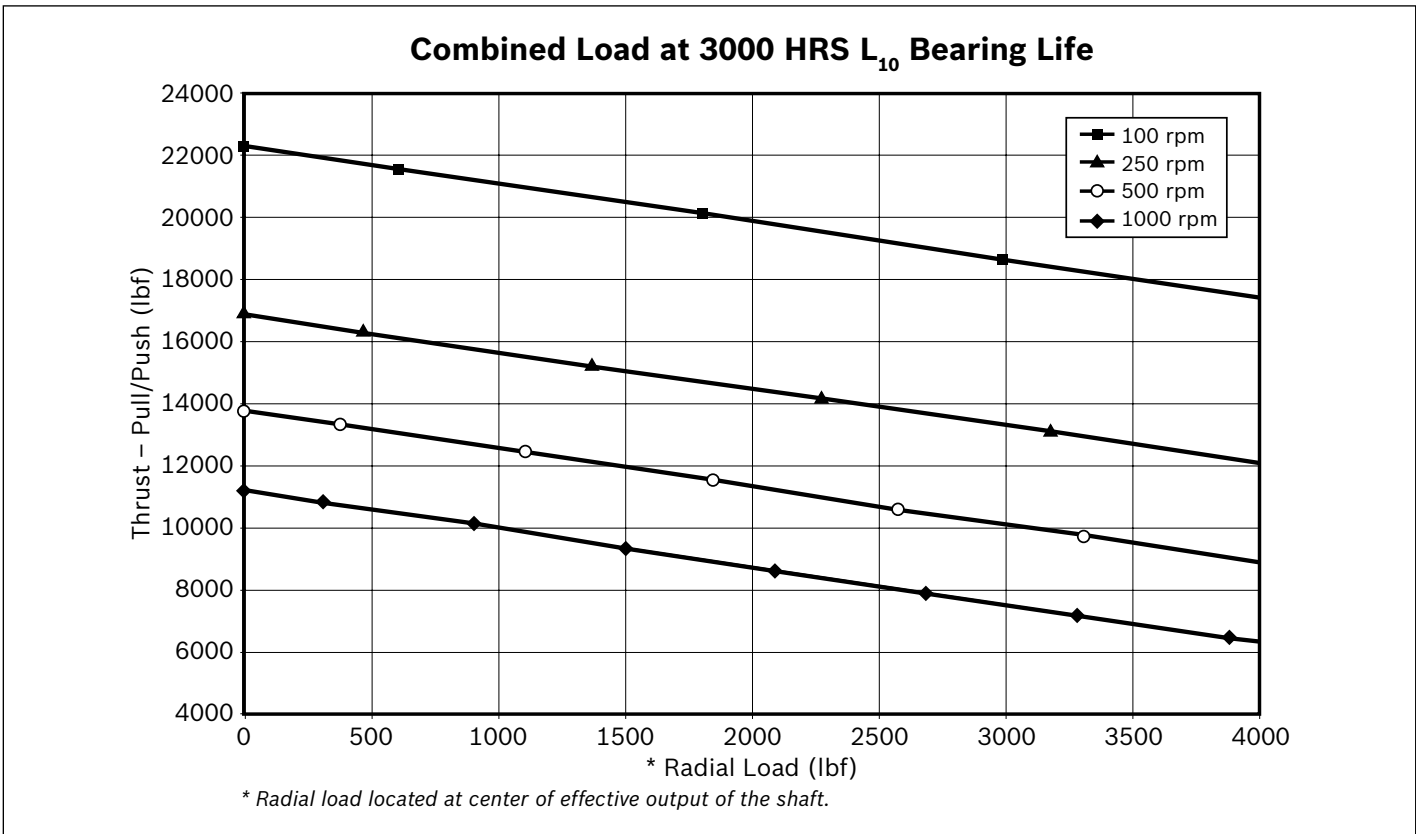
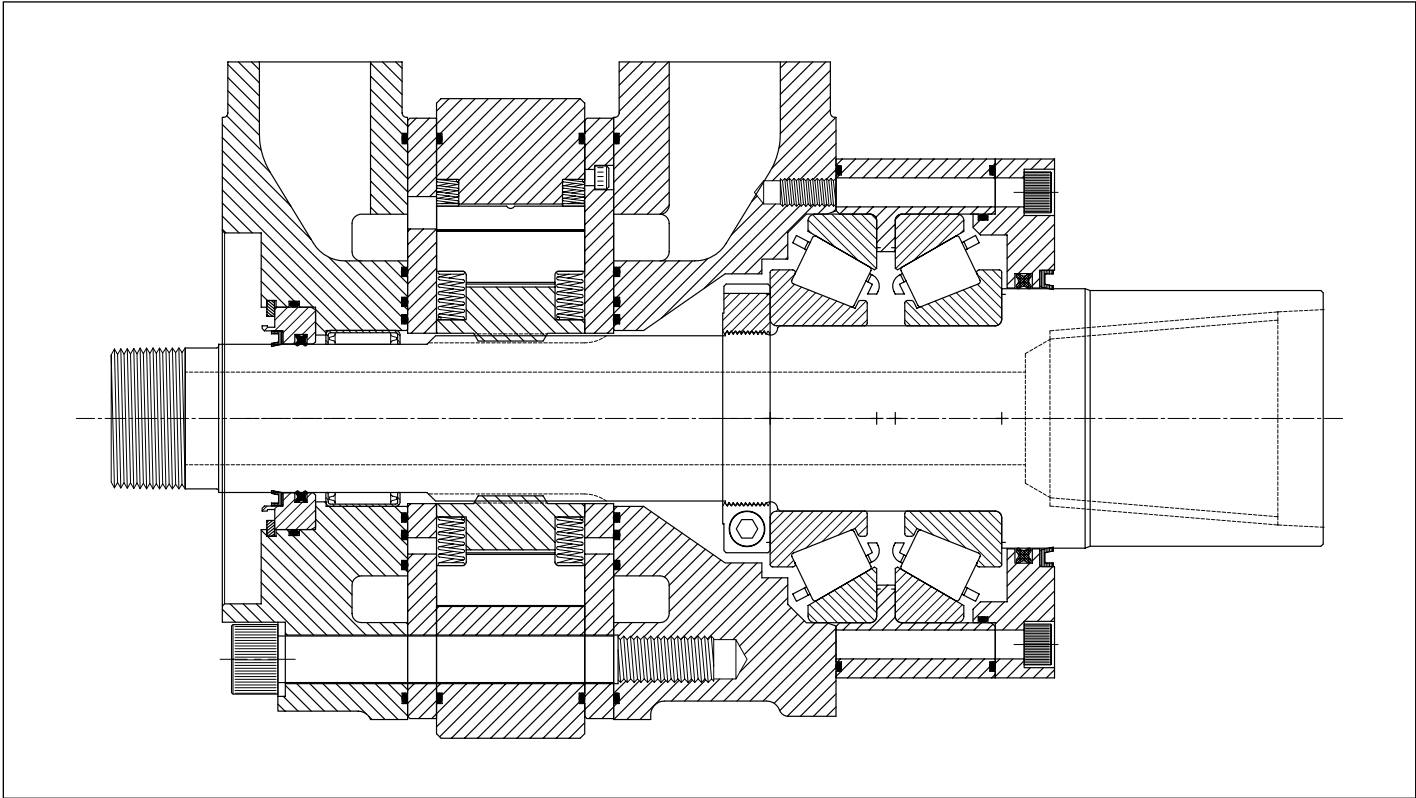

**Technical data**

**Bearing data – Code 62 standard motor (T1 bearing)**

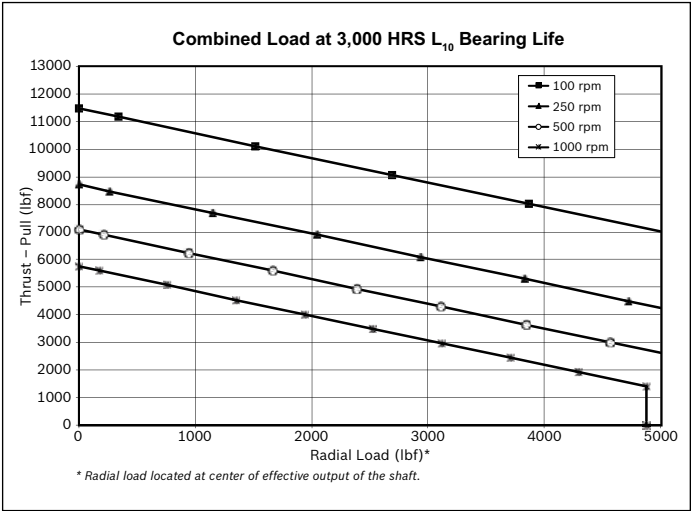
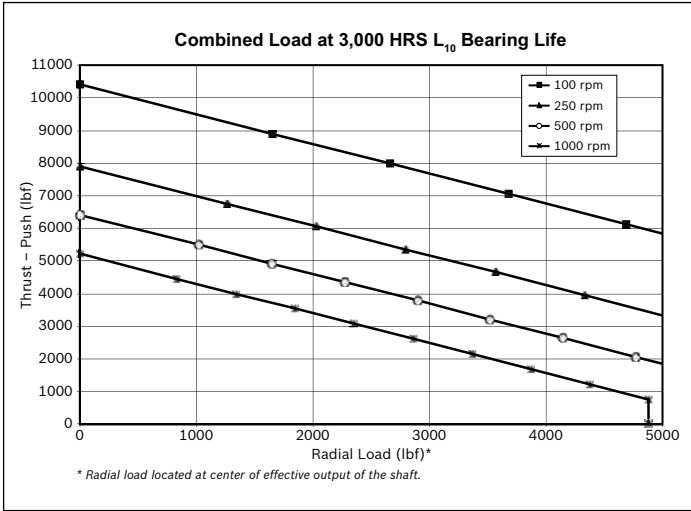
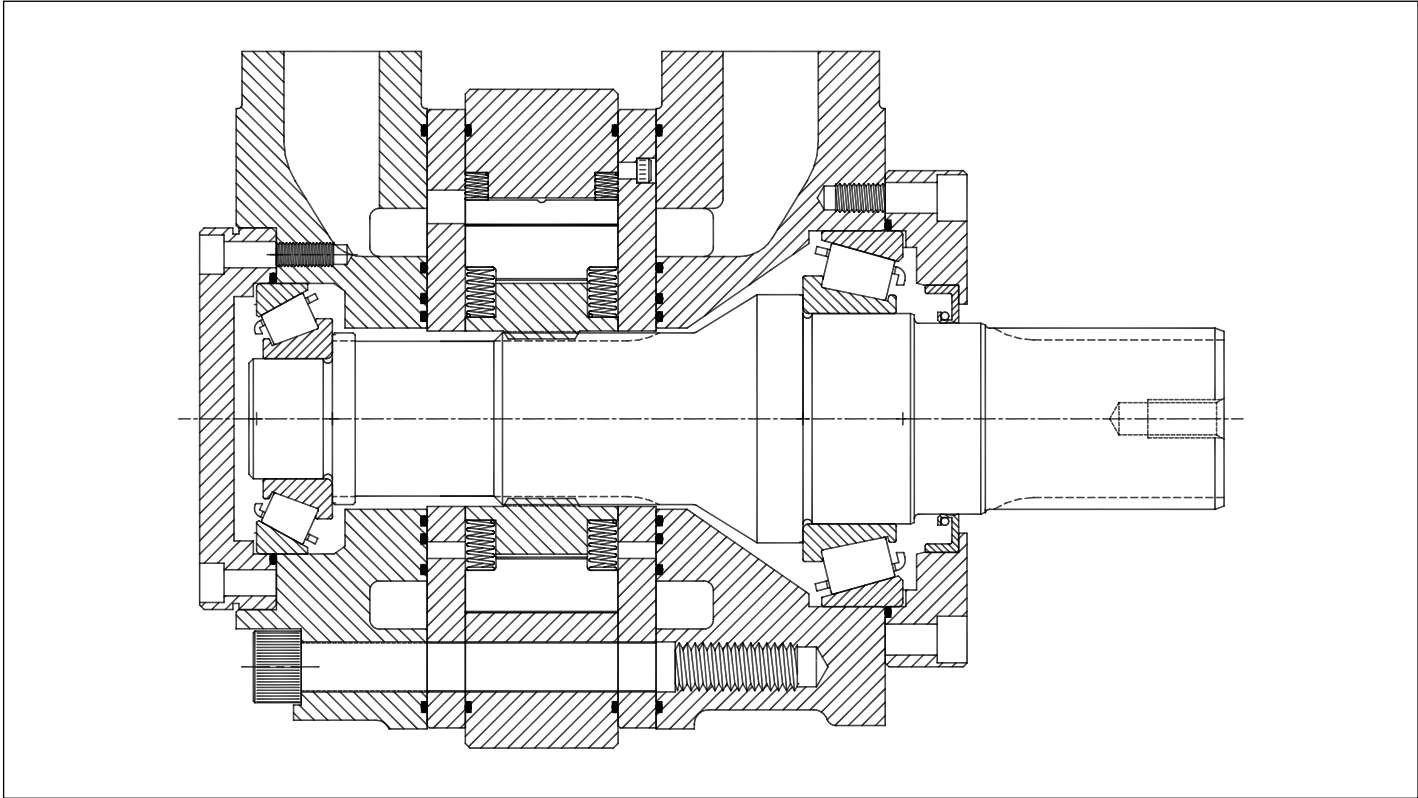

Technical data

Bearing data – Code 62 (T2 bearing)

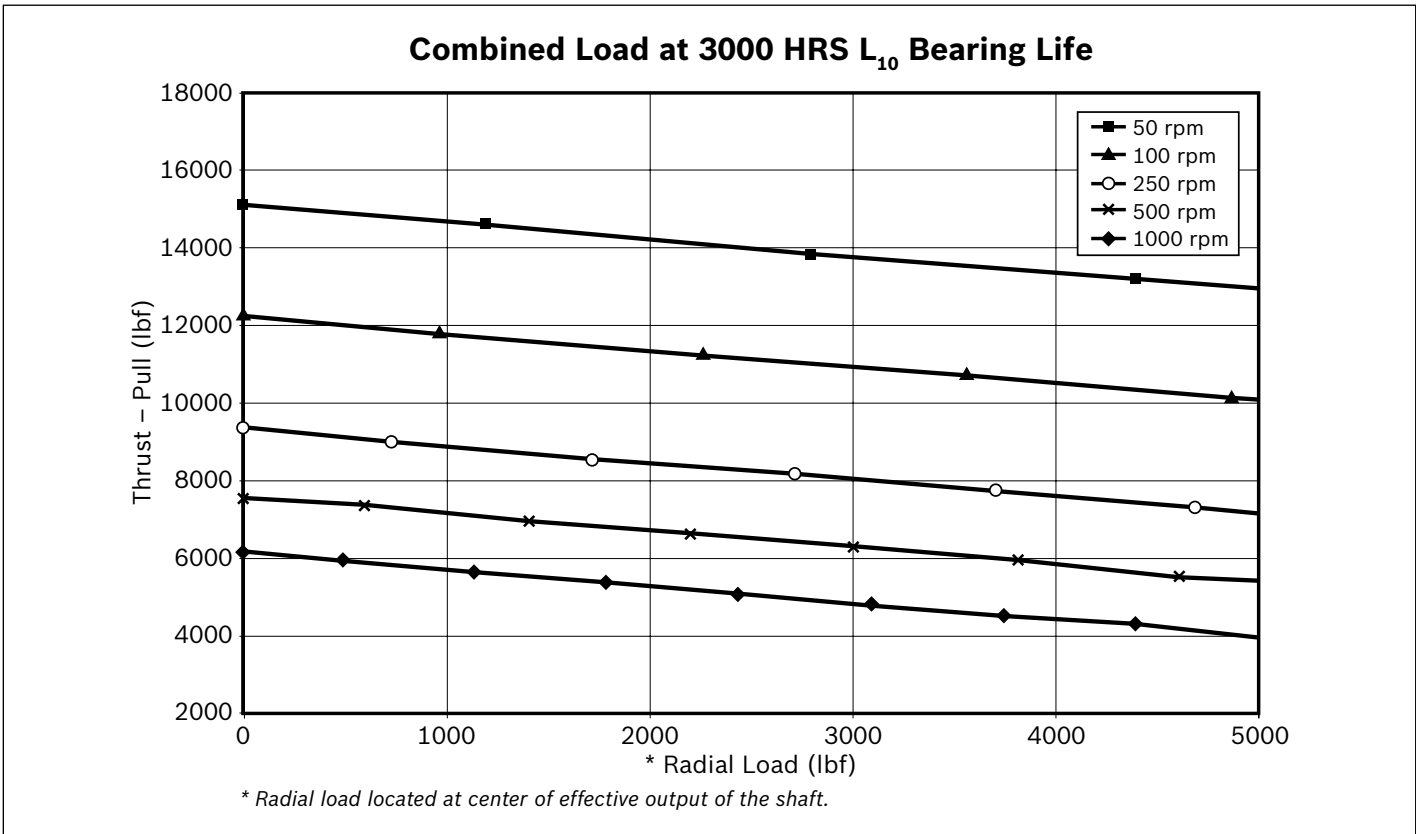
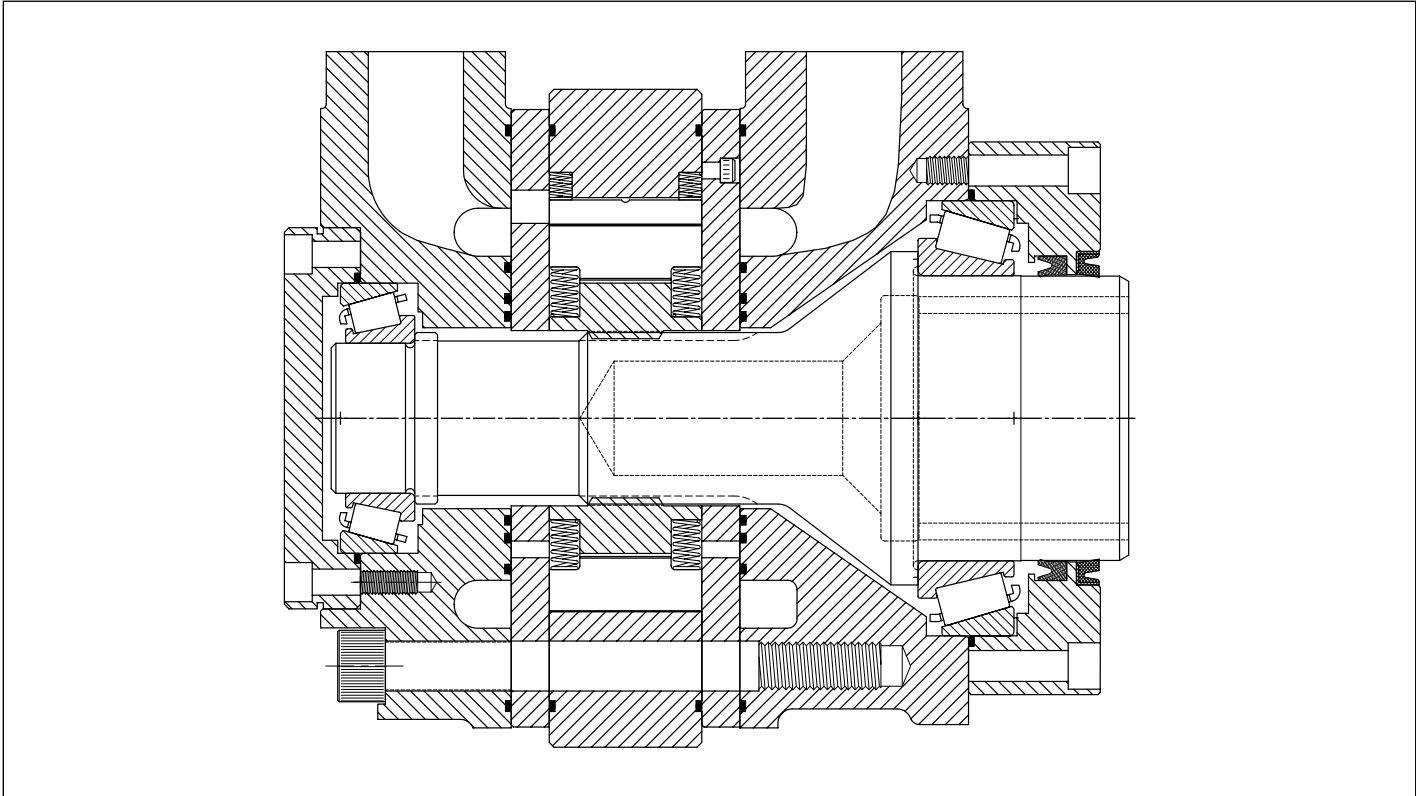

**Technical data**

**Bearing data – Code 62 standard motor (T4 bearing)**

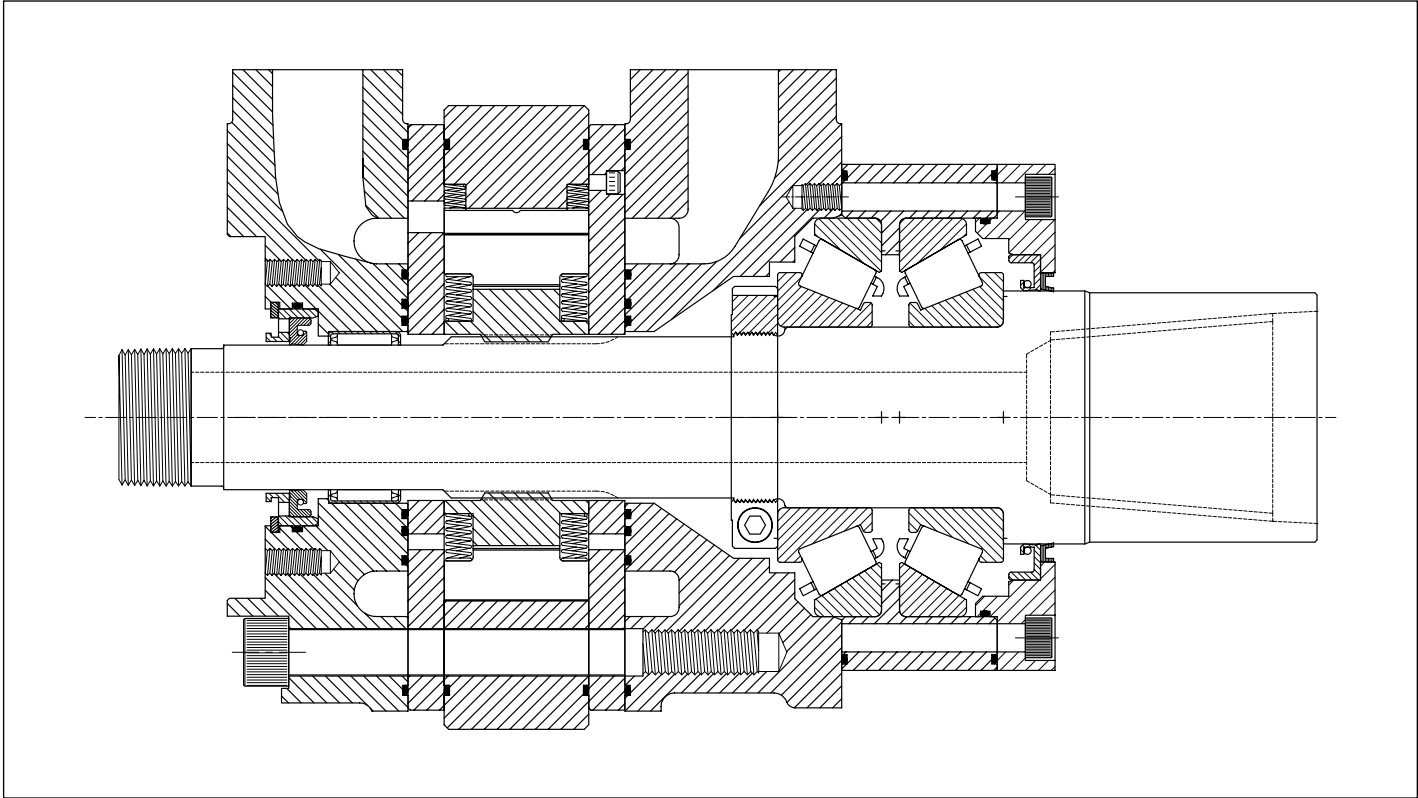

**Combined Load at 3000 HRS  $L_{10}$  Bearing Life**

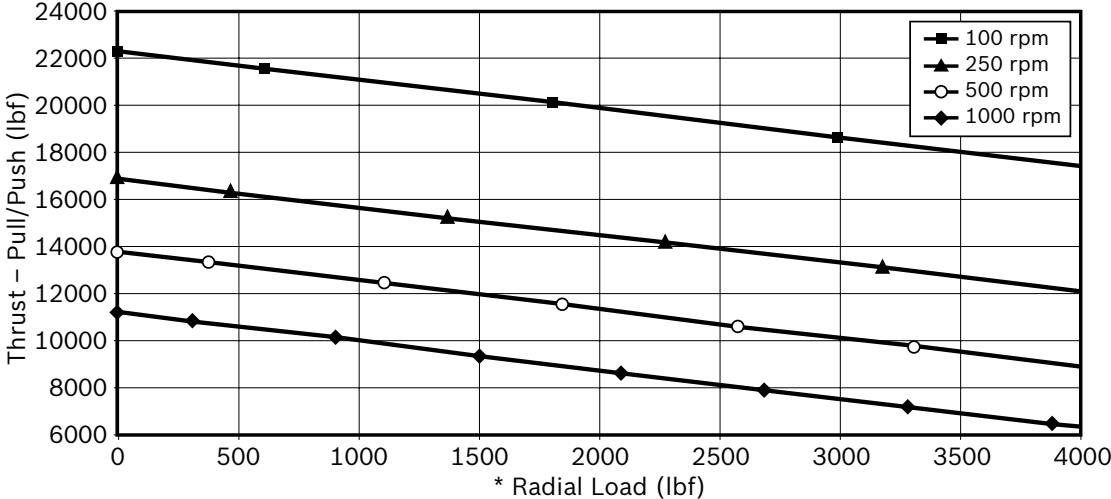

\* Radial load located at center of effective output of the shaft.

Permissible Radial Load		Operating Torque	
(lbf)	(N)	(ft-lbf)	(N-m)
3500	15569	3062-3115	4151-4224
3000	13345	3384-3438	4588-4661
2500	11121	3706	5025
2000	8896	3975	5389

For additional information, consult factory.

**Technical data**

**Bearing data – Code 62 standard motor (T5 bearing)**

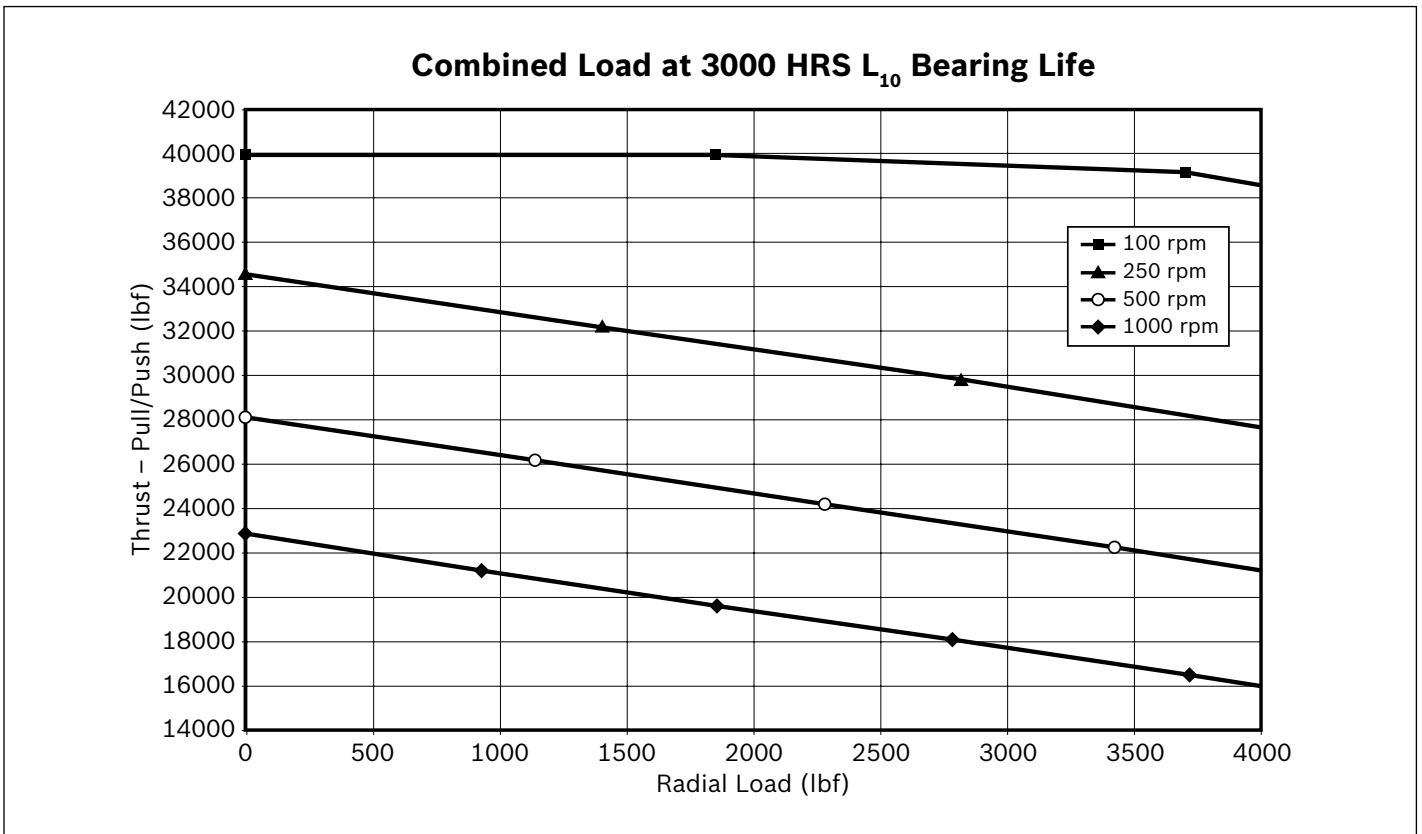
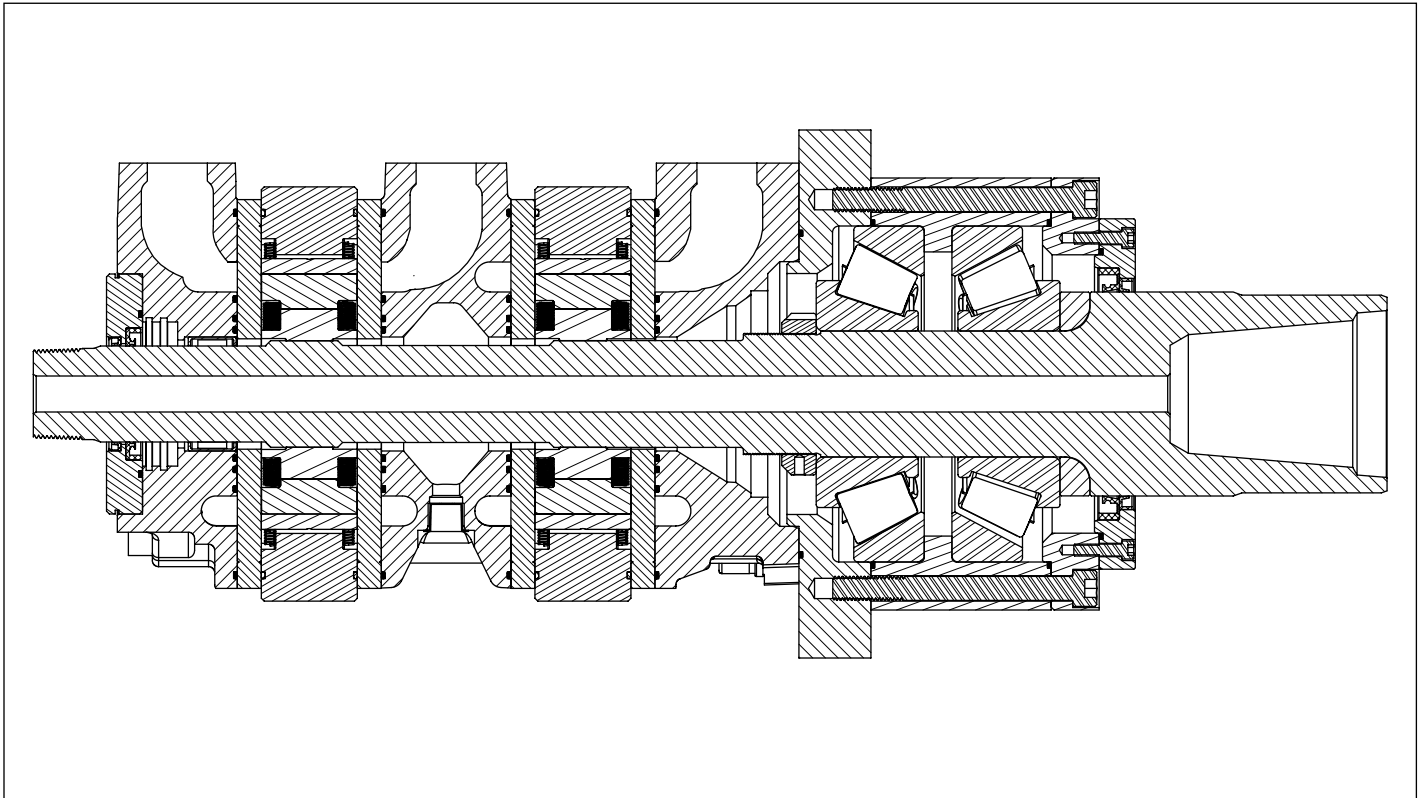



The drawings on the following pages represent basic motor configurations.

**Unit dimensions**

**Code 61 (B1 bearing)**

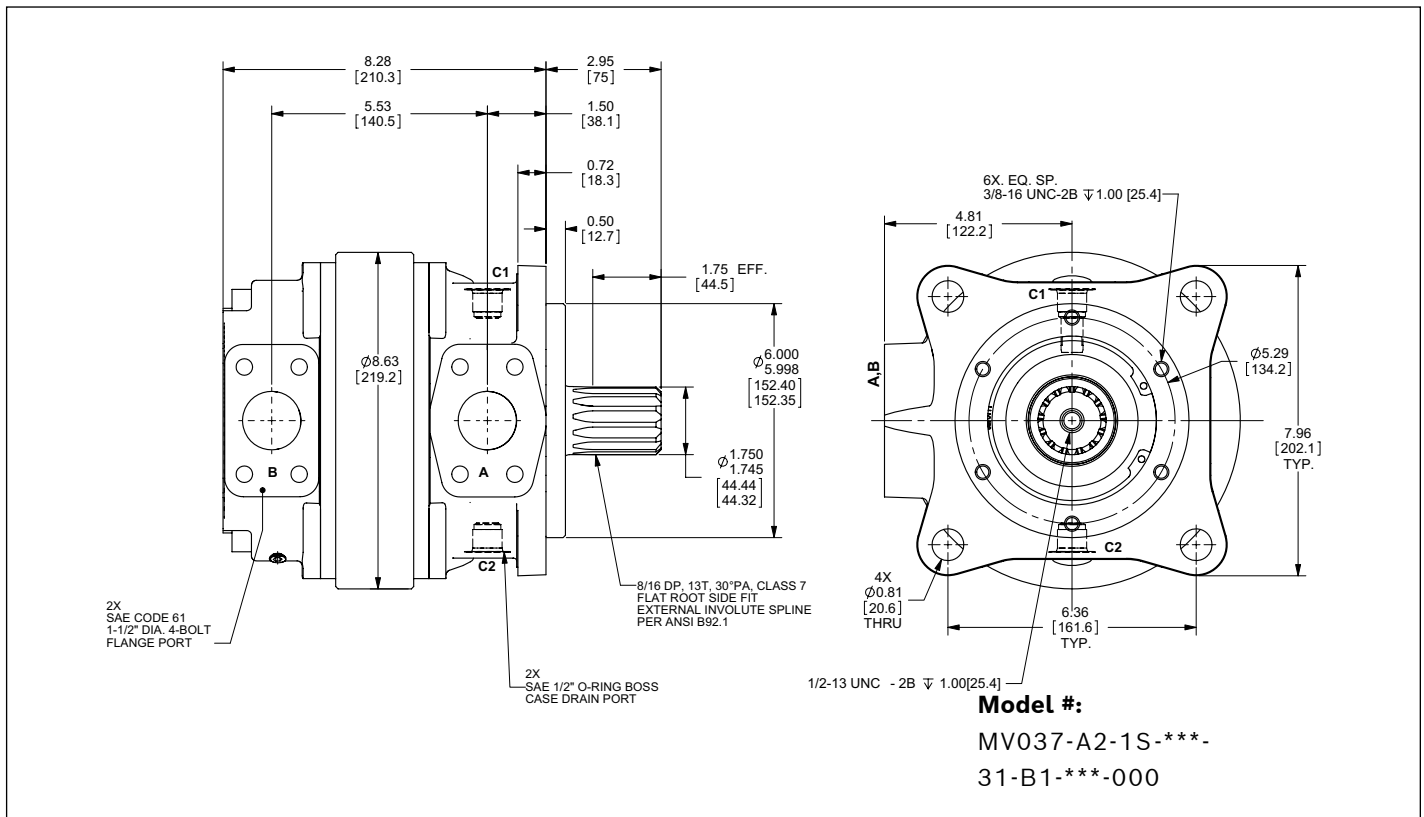
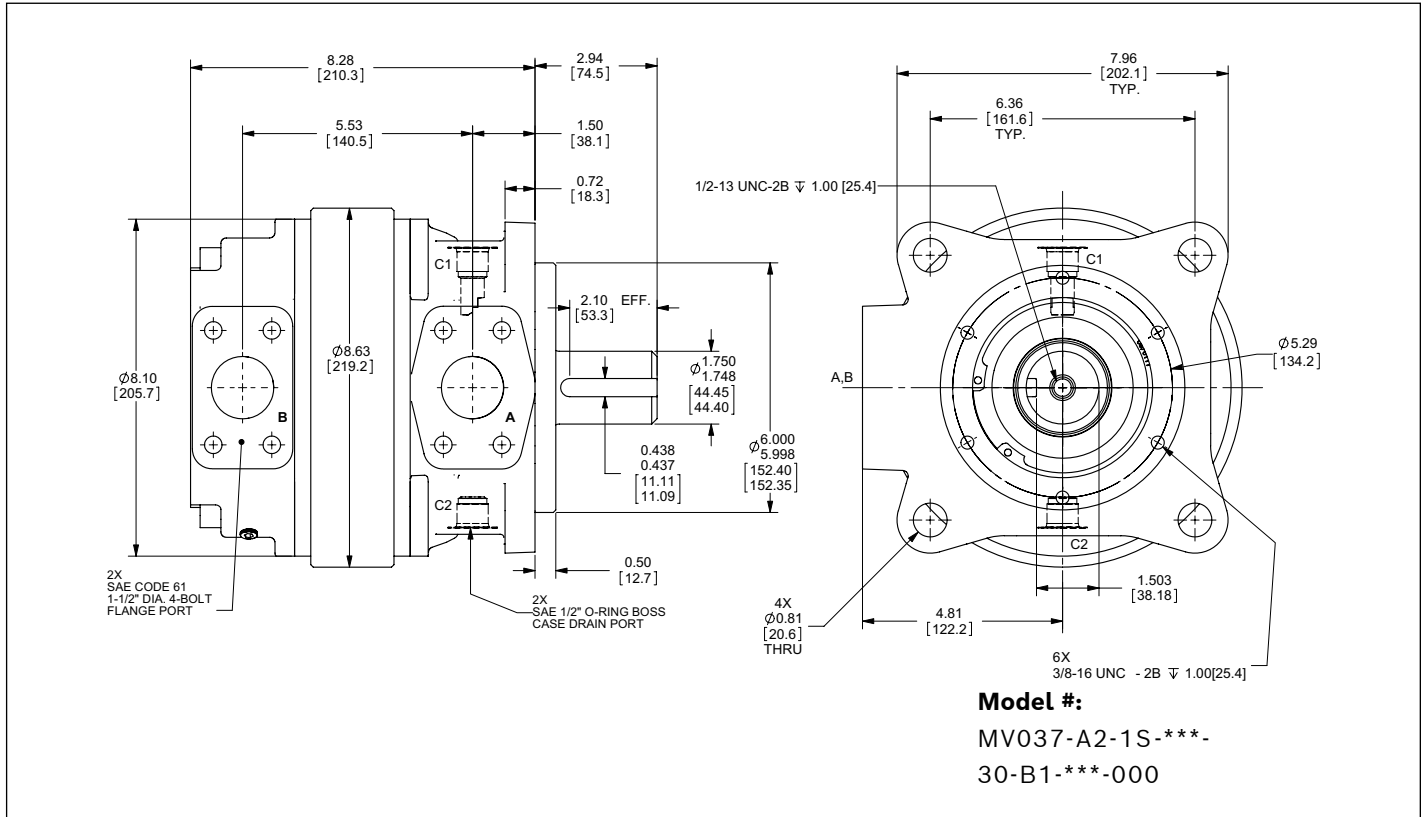

Unit dimensions

Code 61 (B1 bearing) – continued

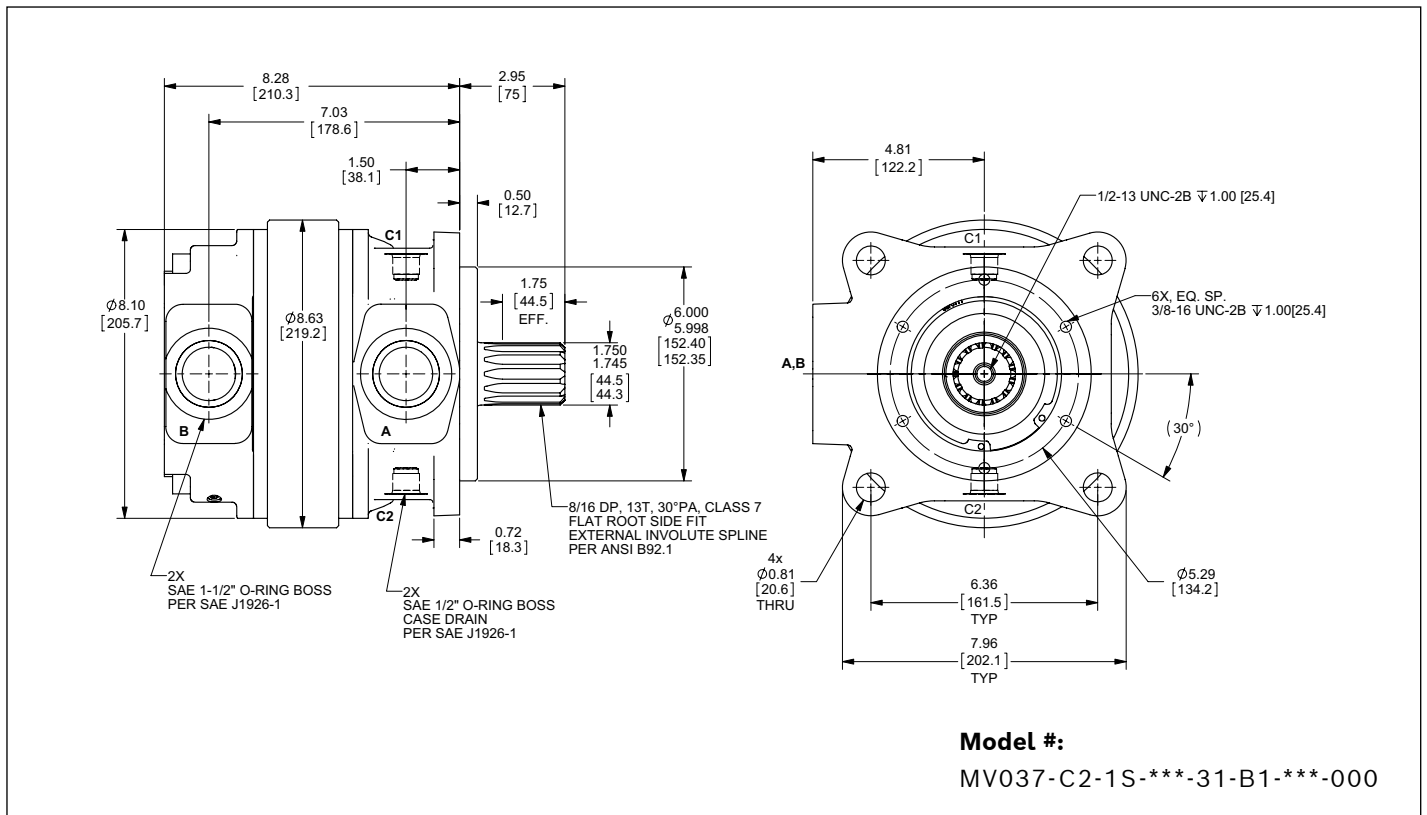
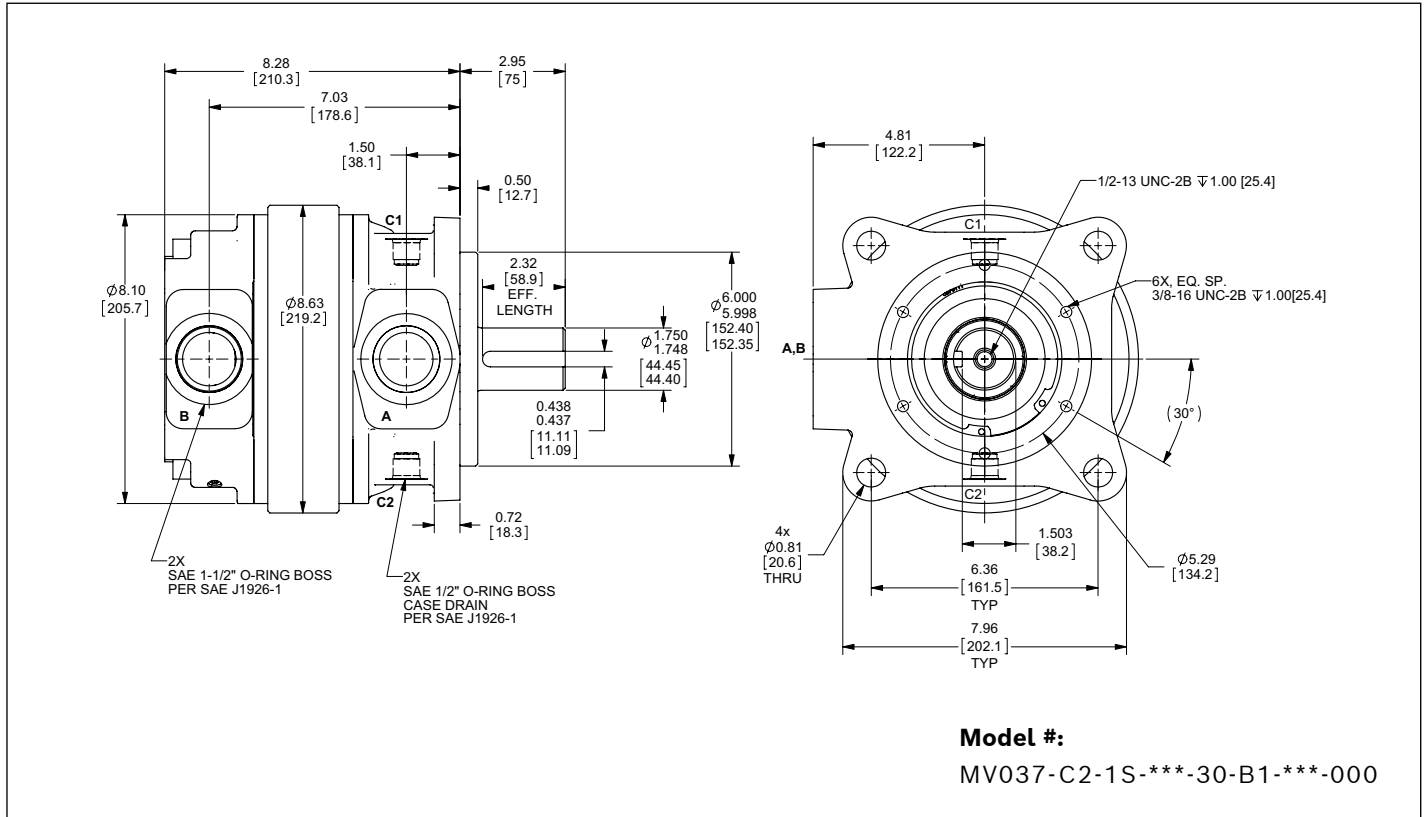

Unit dimensions

Code 61 (B1 bearing) – continued

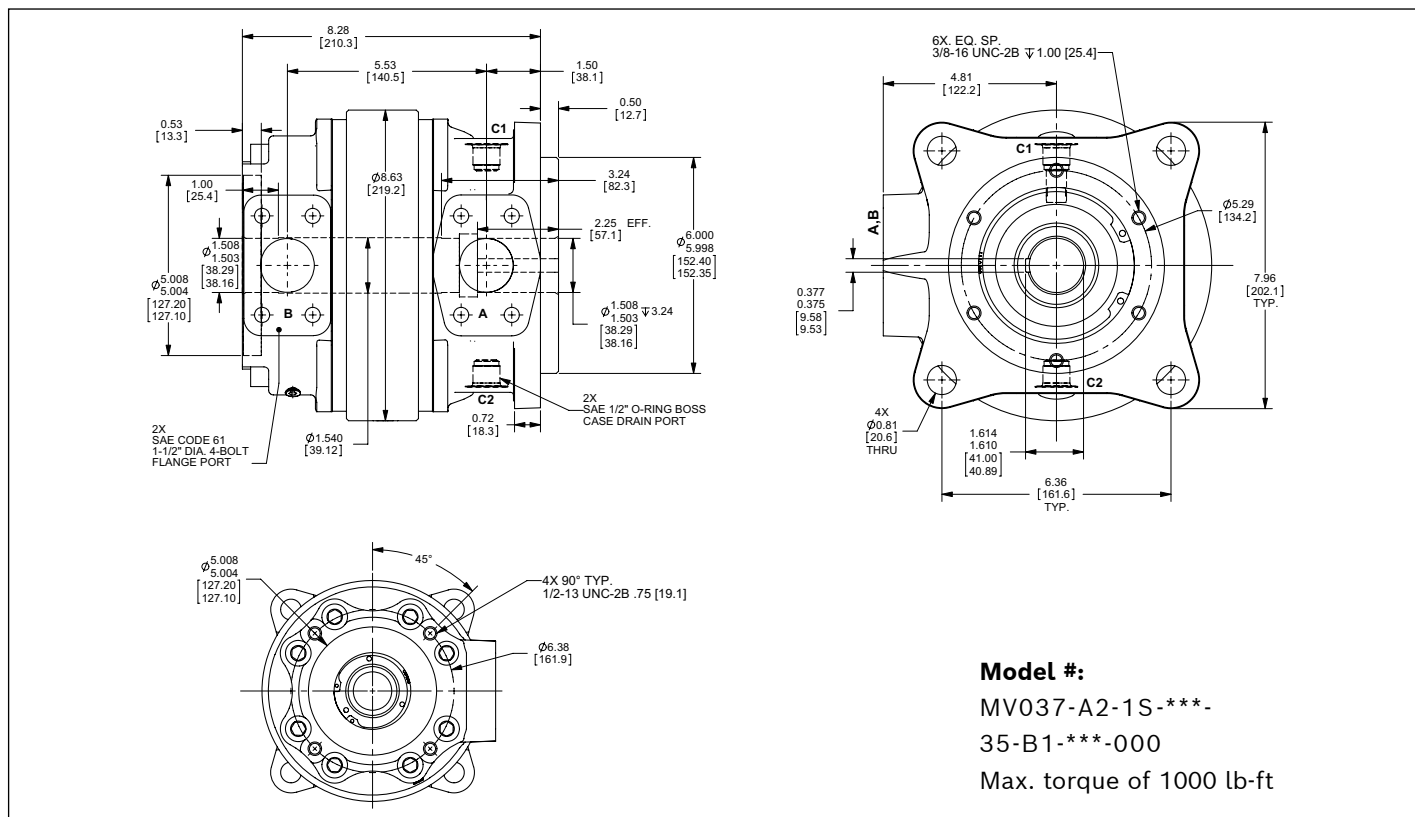
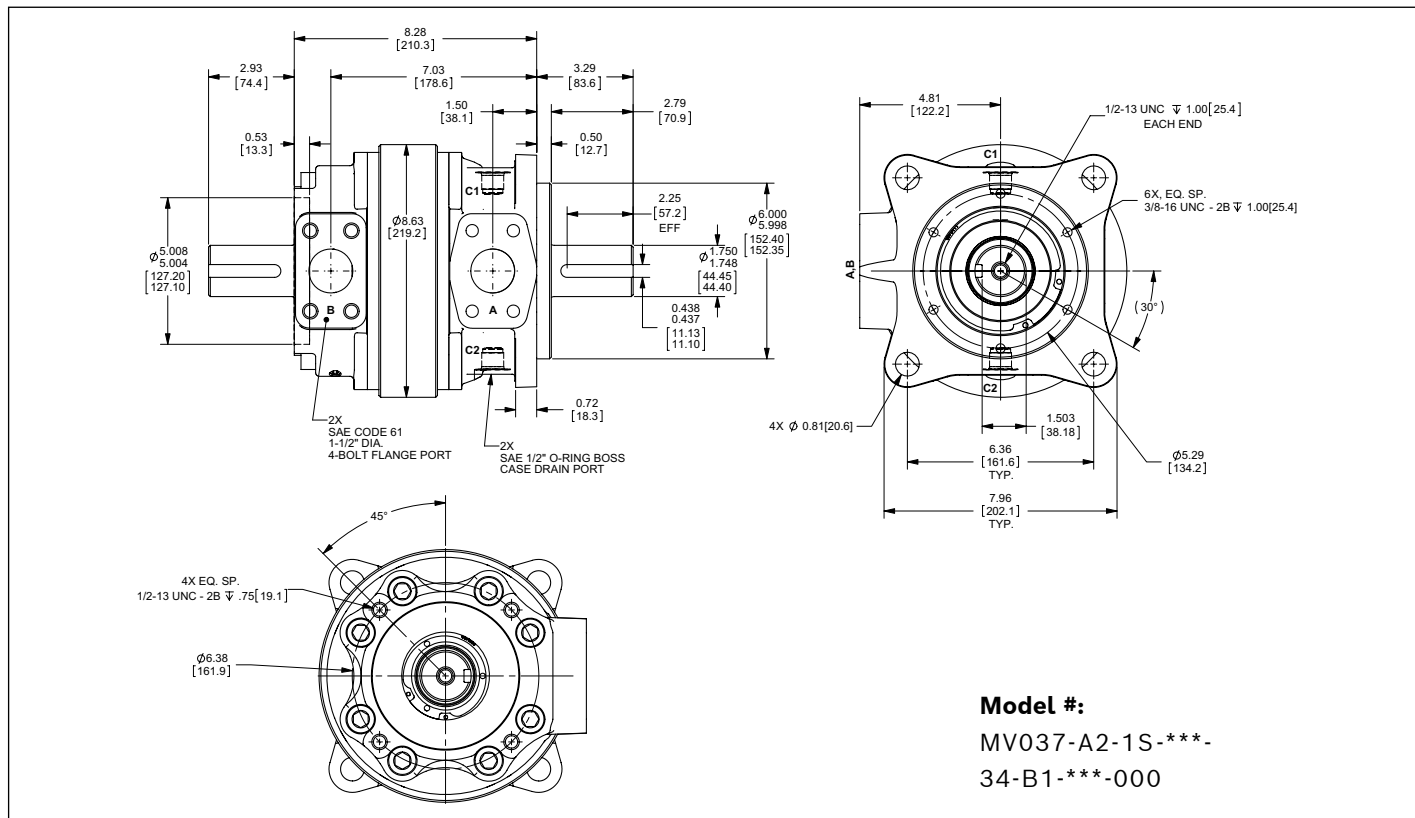

Unit dimensions

Code 61 (B1 bearing) – continued

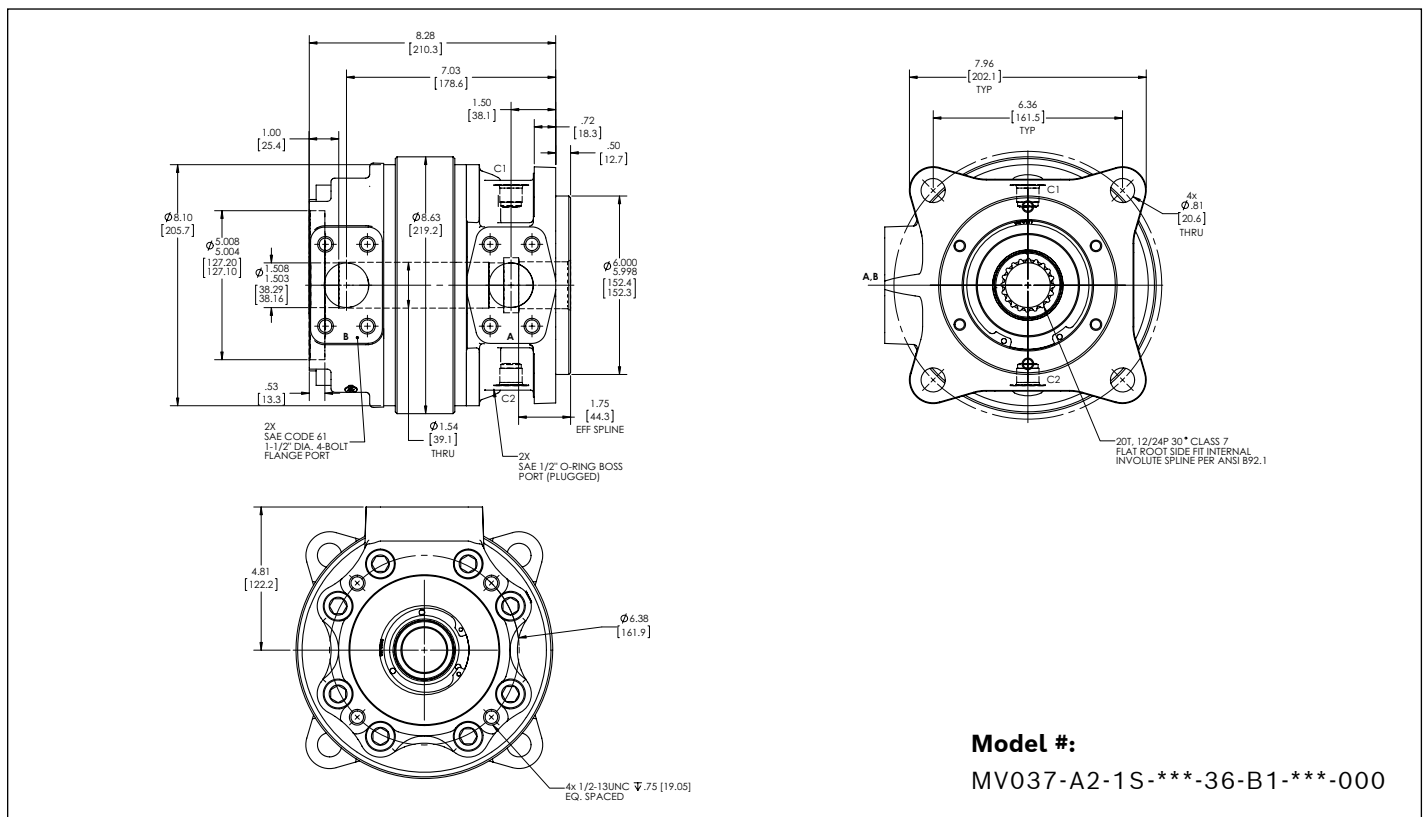
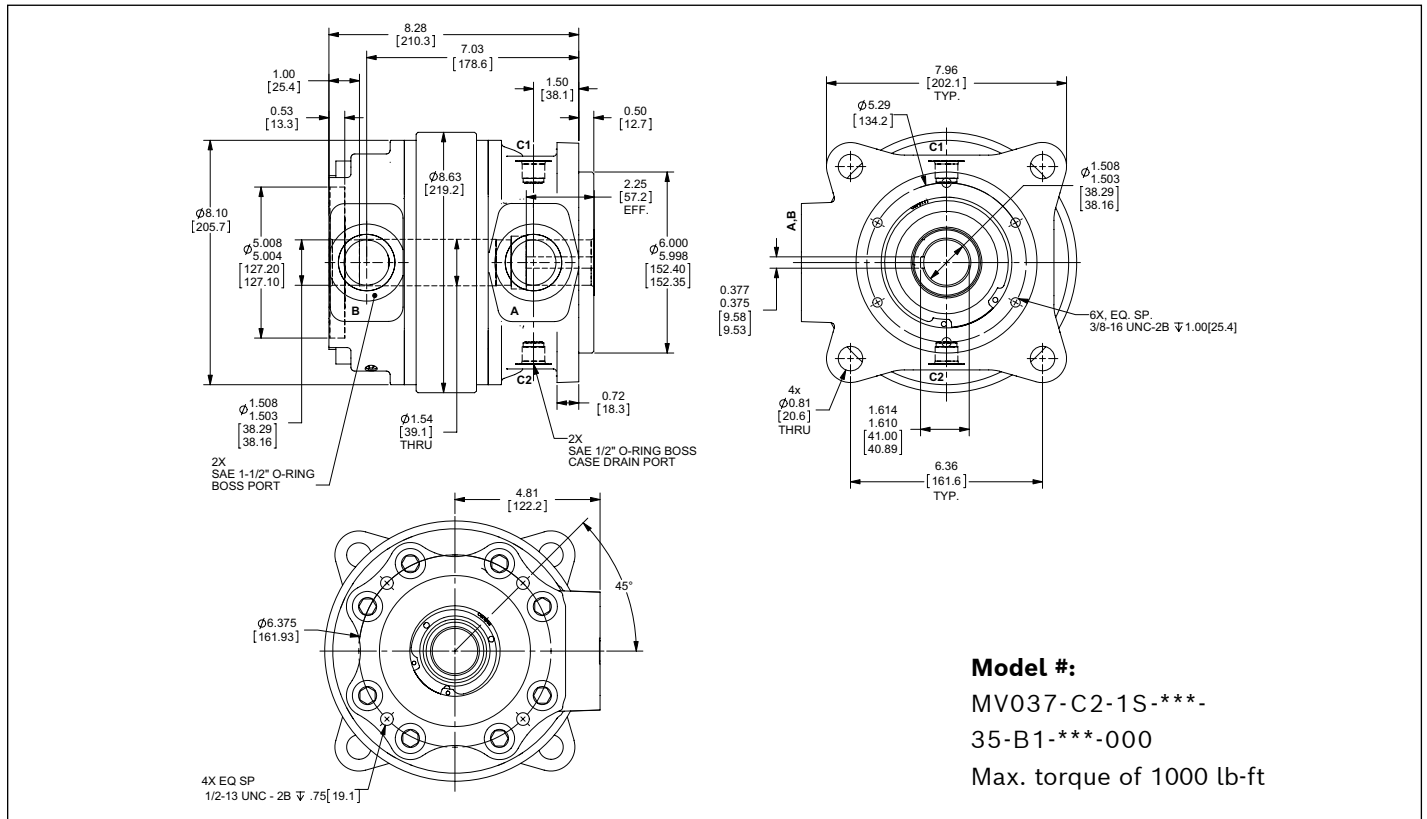

Unit dimensions

Code 61 (B1 bearing) – continued

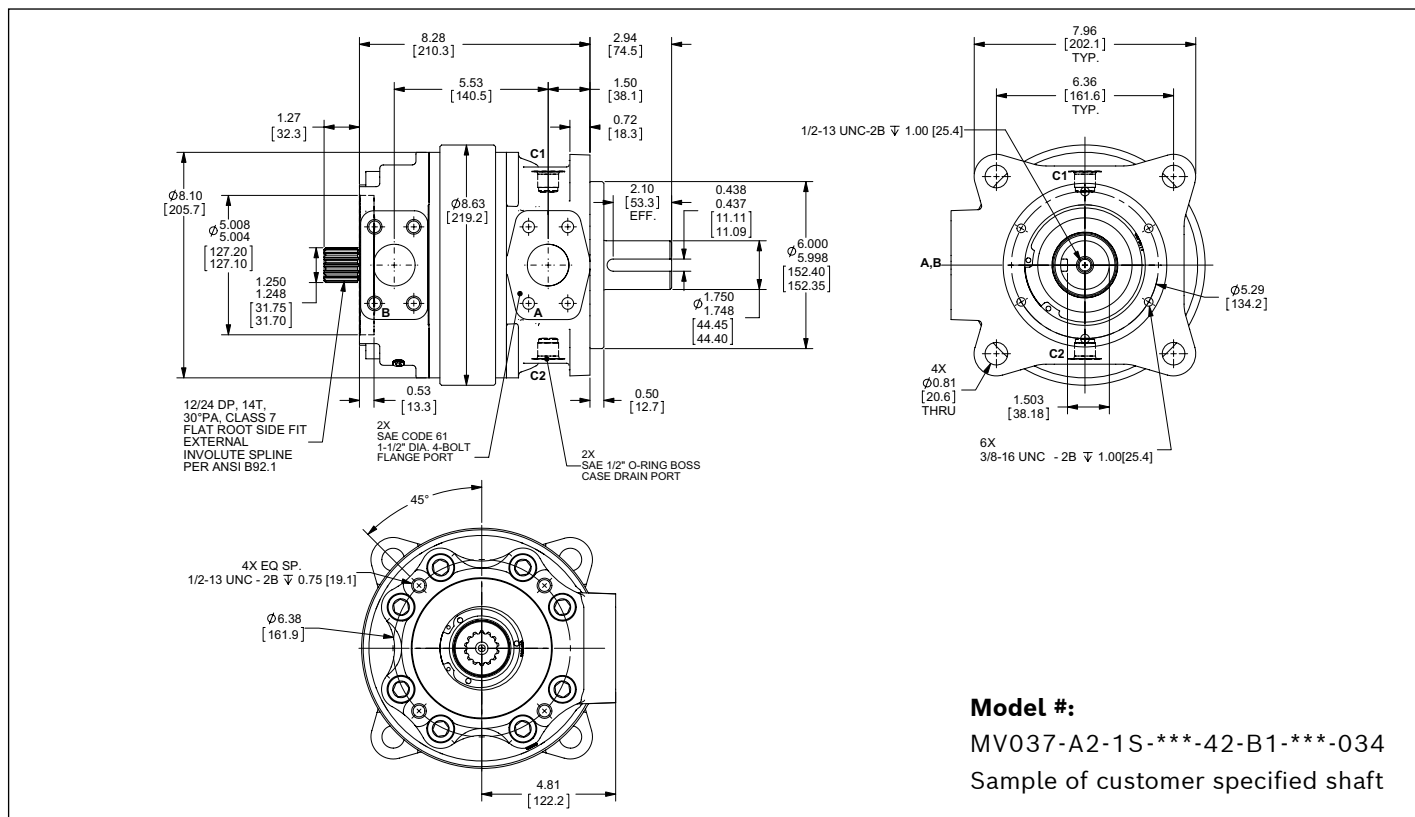
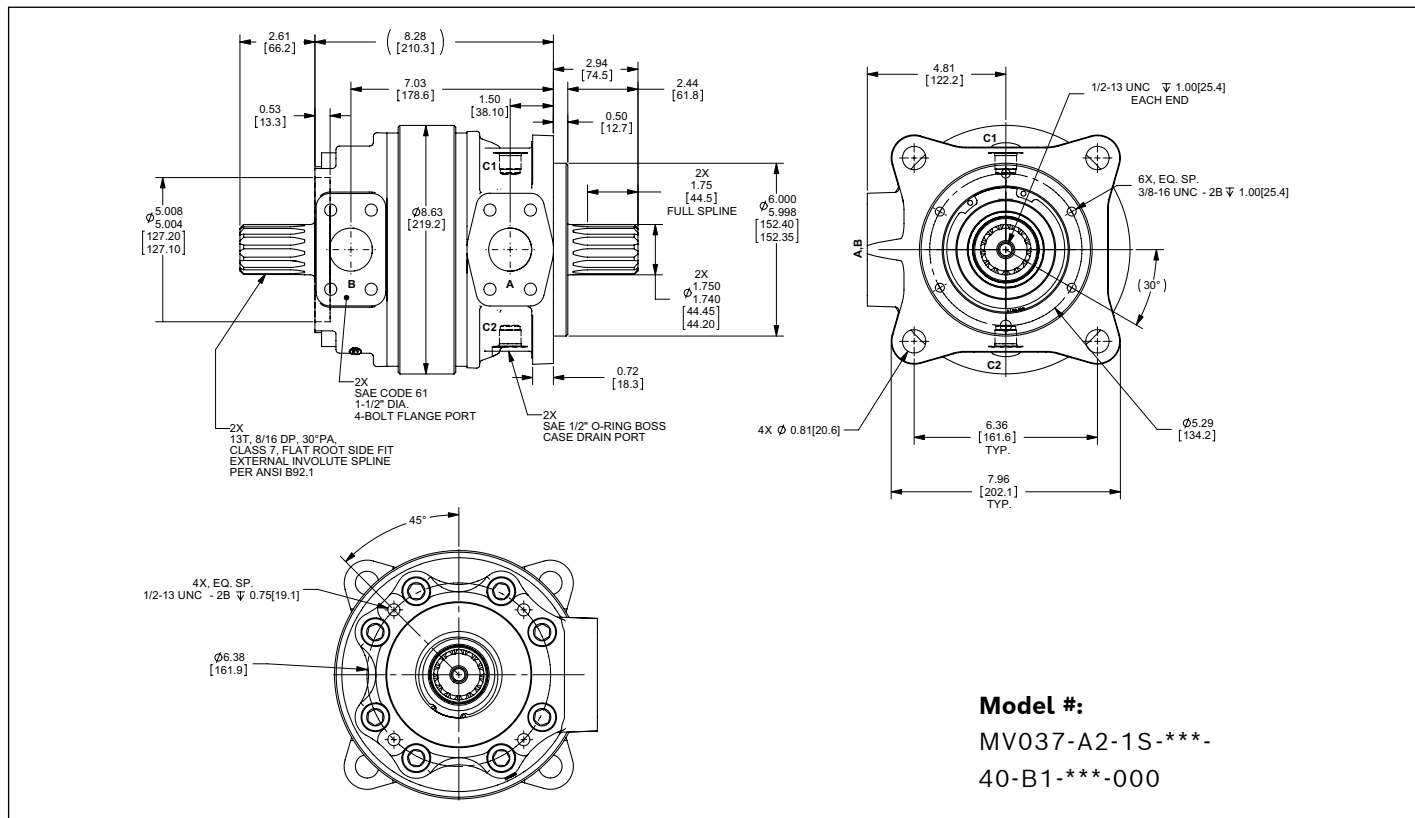

Unit dimensions

Code 61 (B1 bearing) – continued

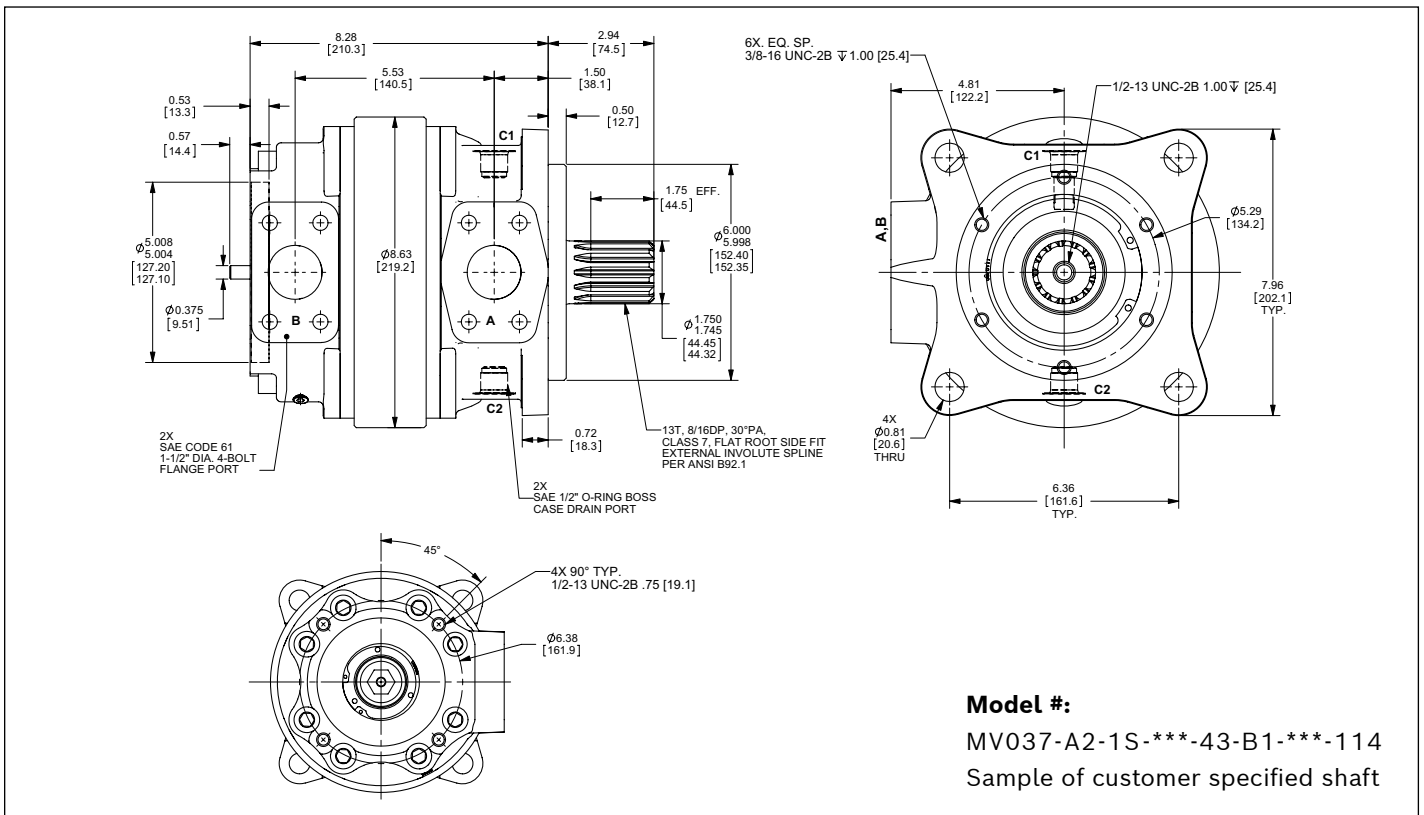
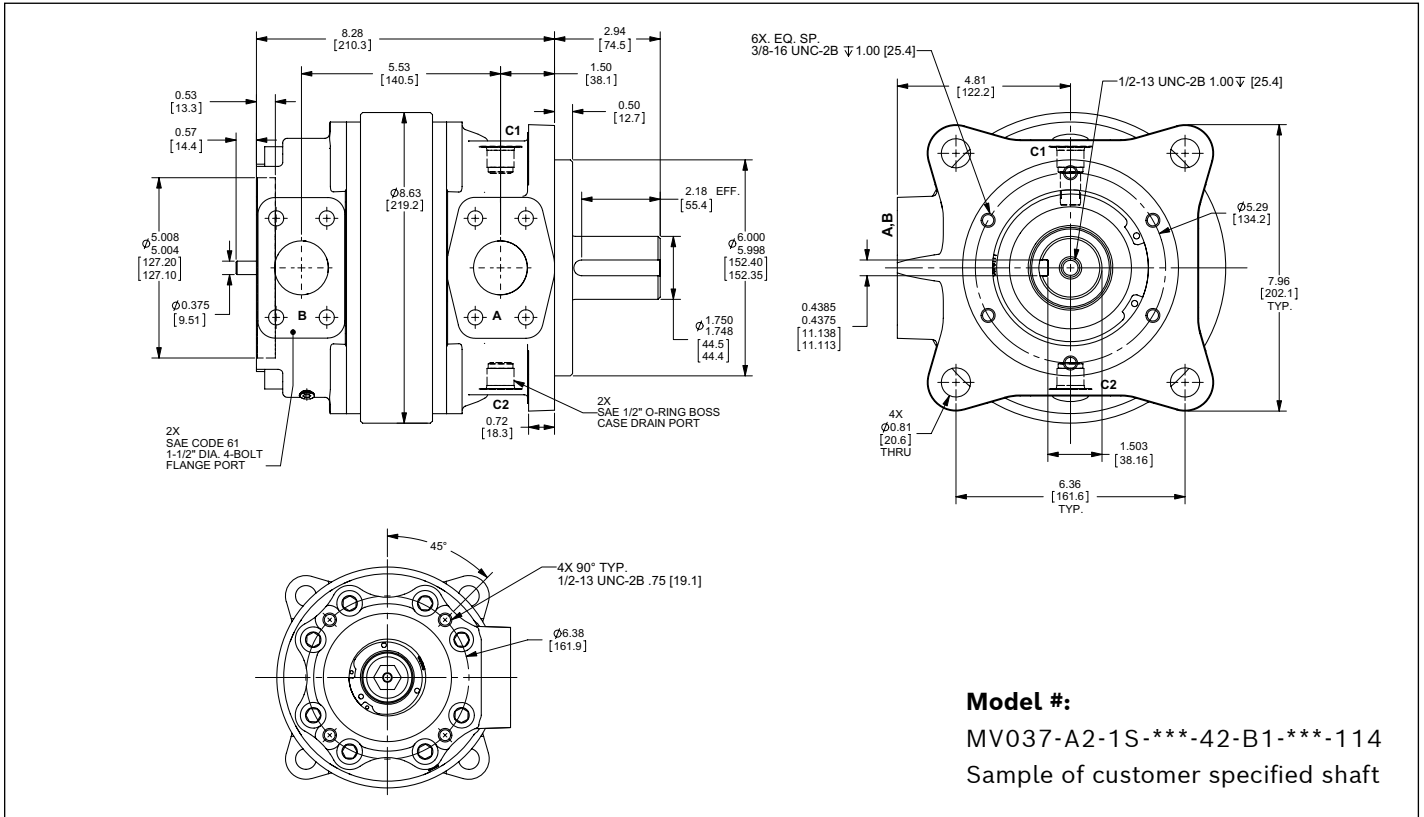



Unit dimensions

Code 61 (B3 bearing)

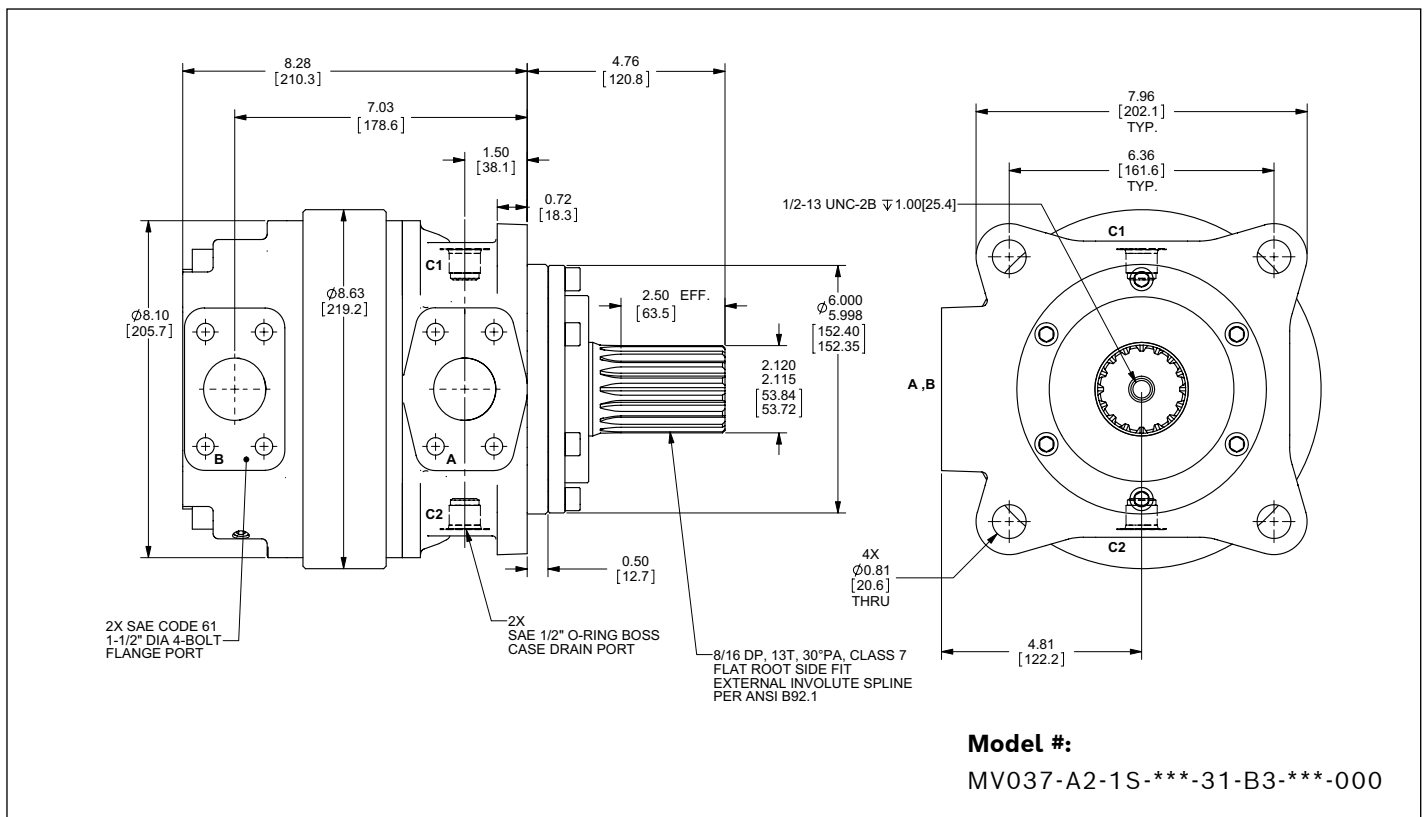
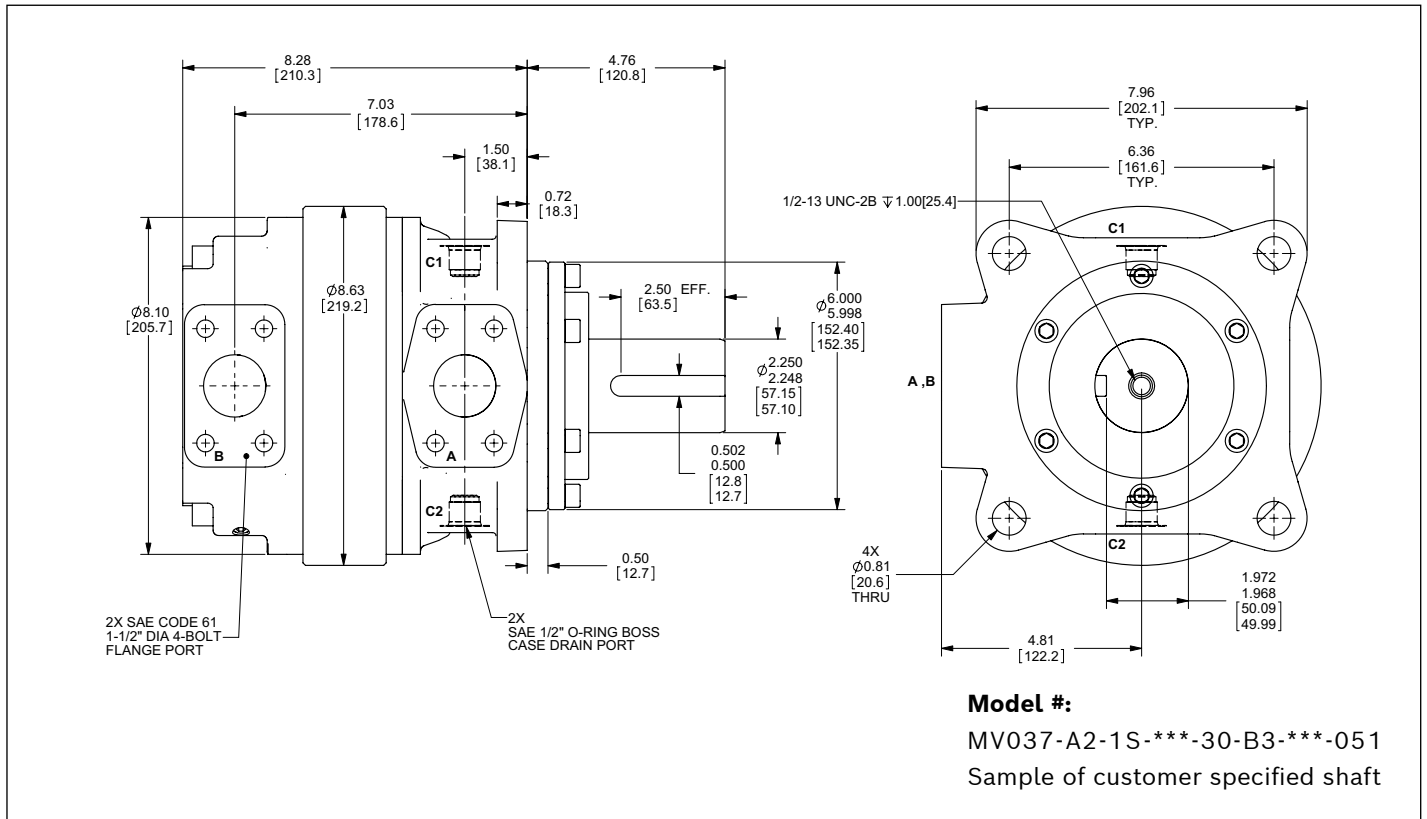



Unit dimensions

Code 61 (B3 bearing) – continued

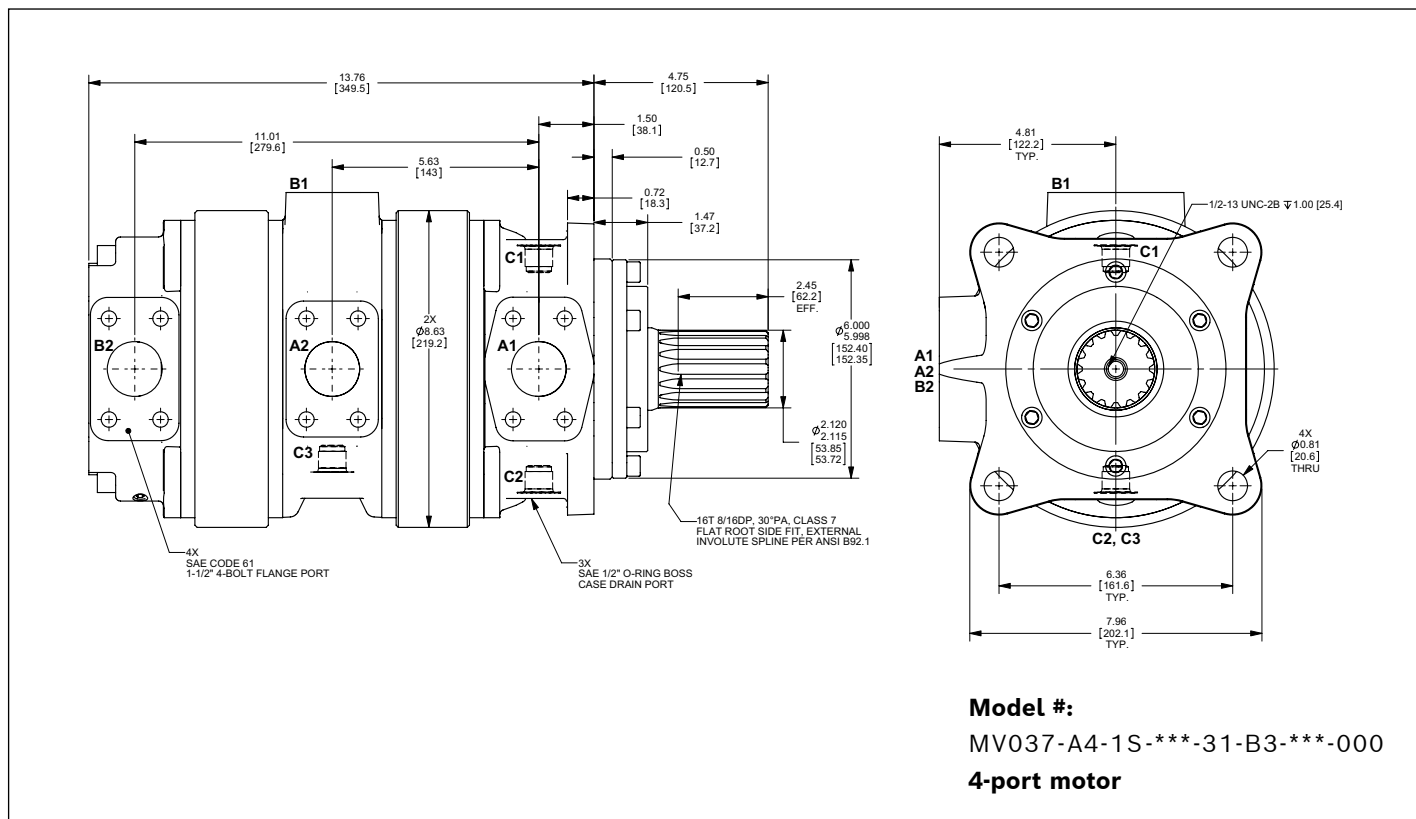
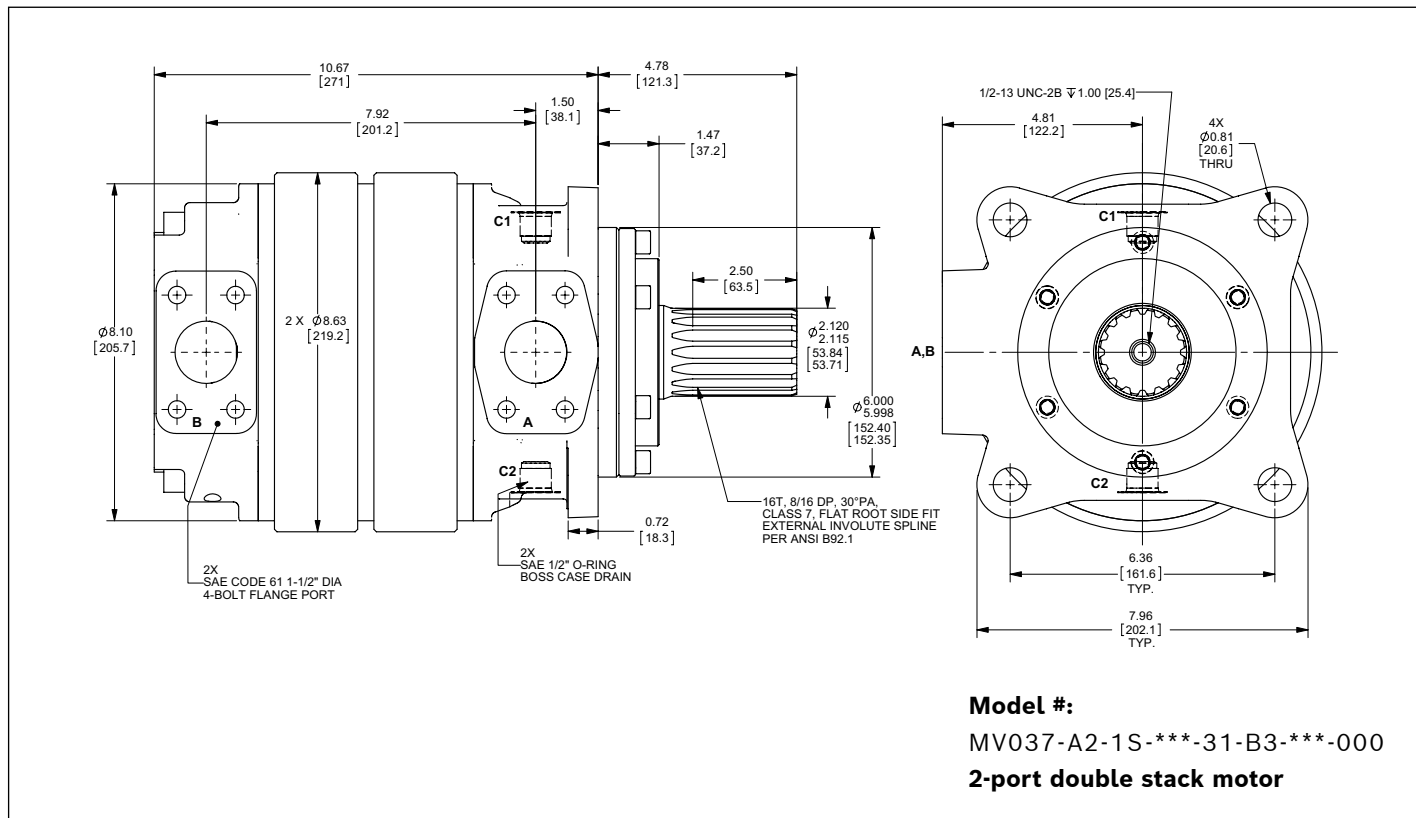

Unit dimensions

Code 61 (B3 bearing) – continued

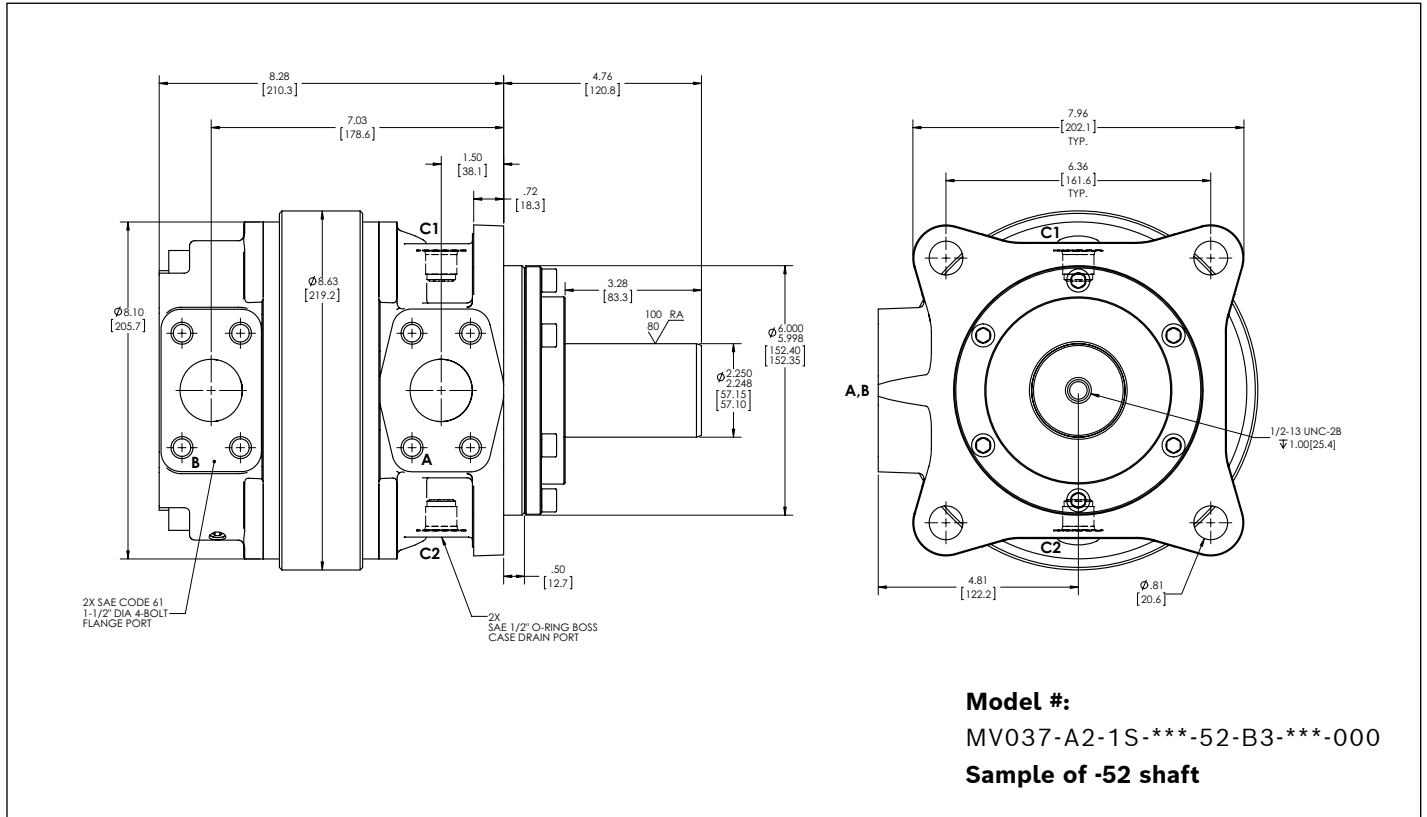

Unit dimensions

Code 62 (T1 bearing)

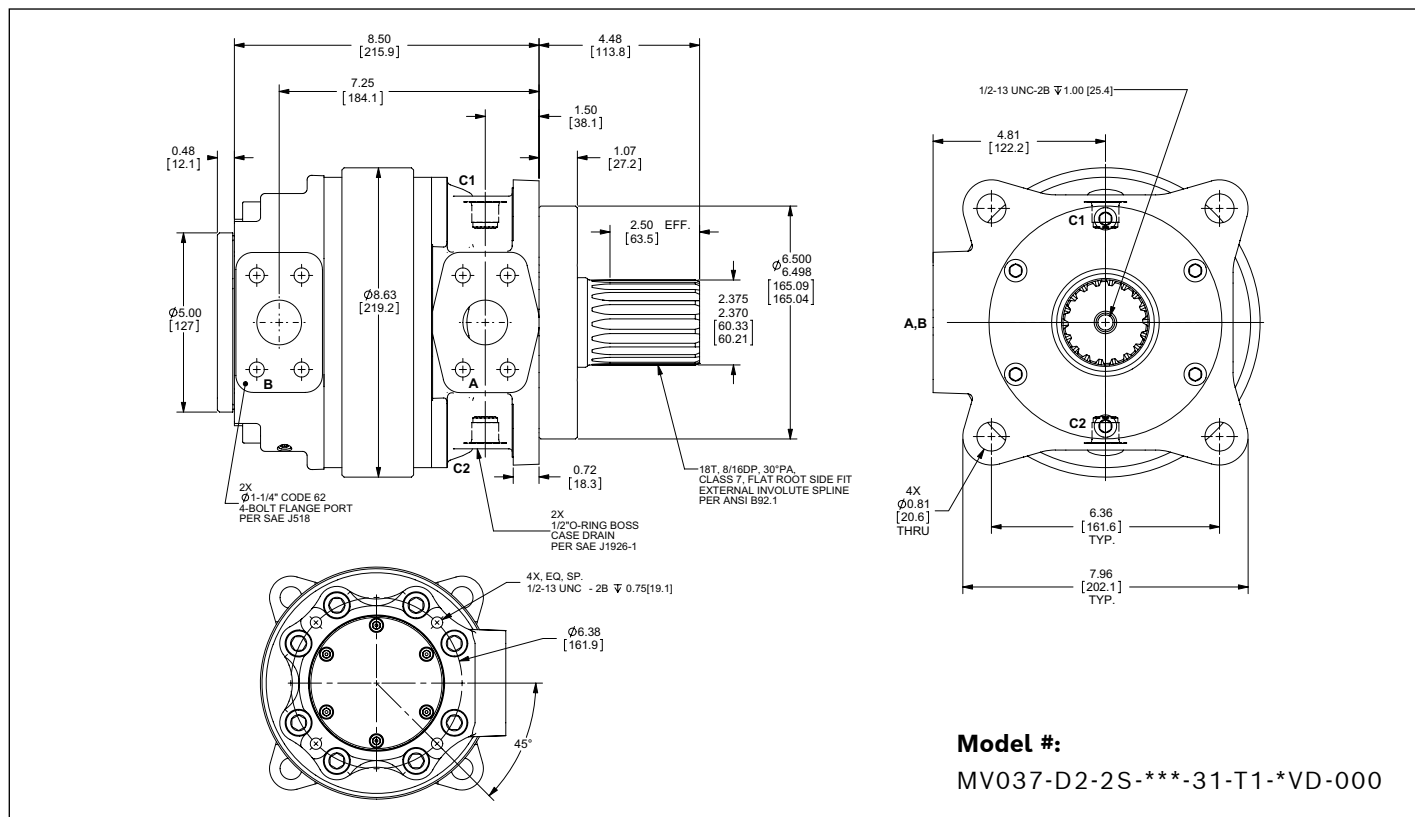
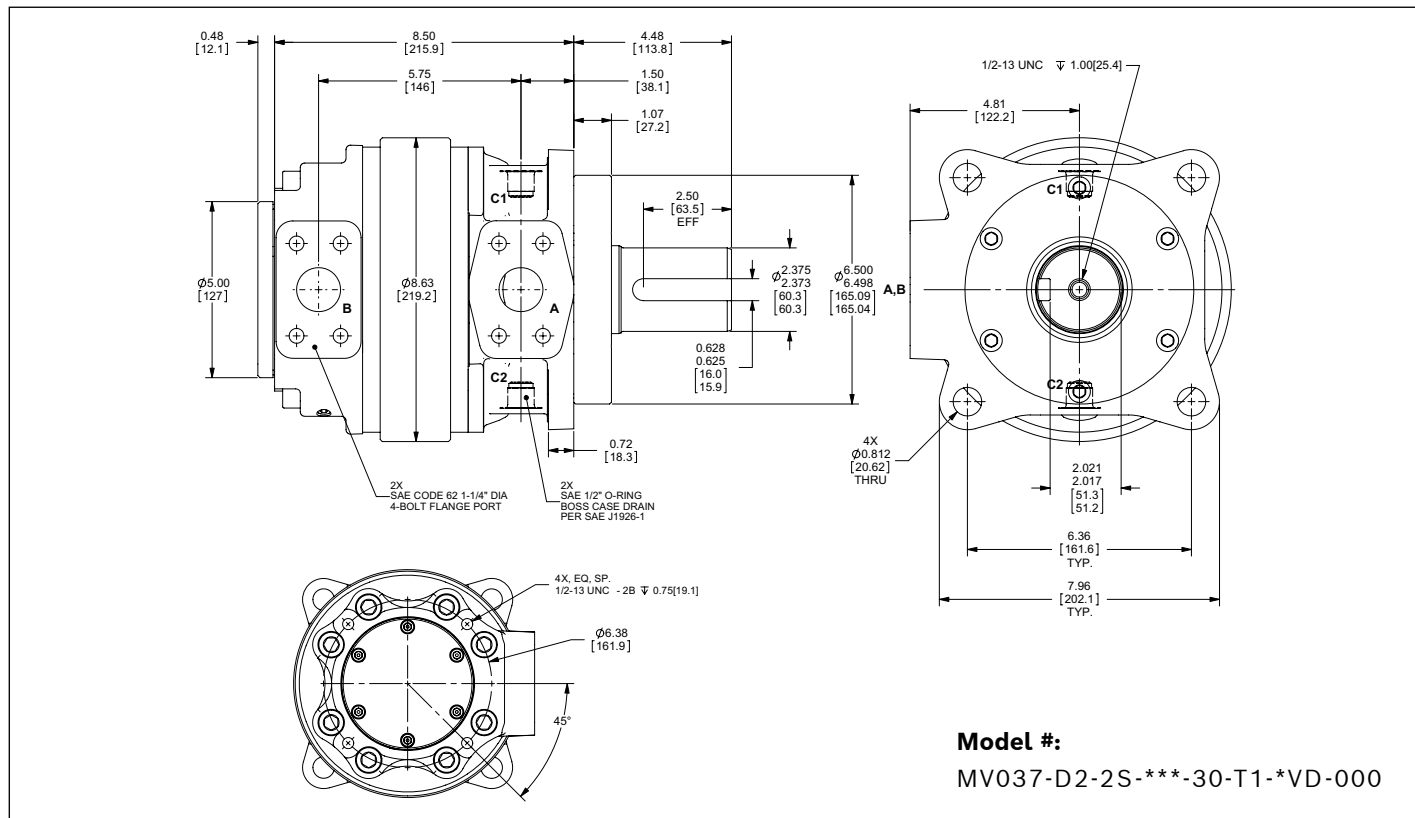

Unit dimensions

Code 62 (T1 bearing) – continued

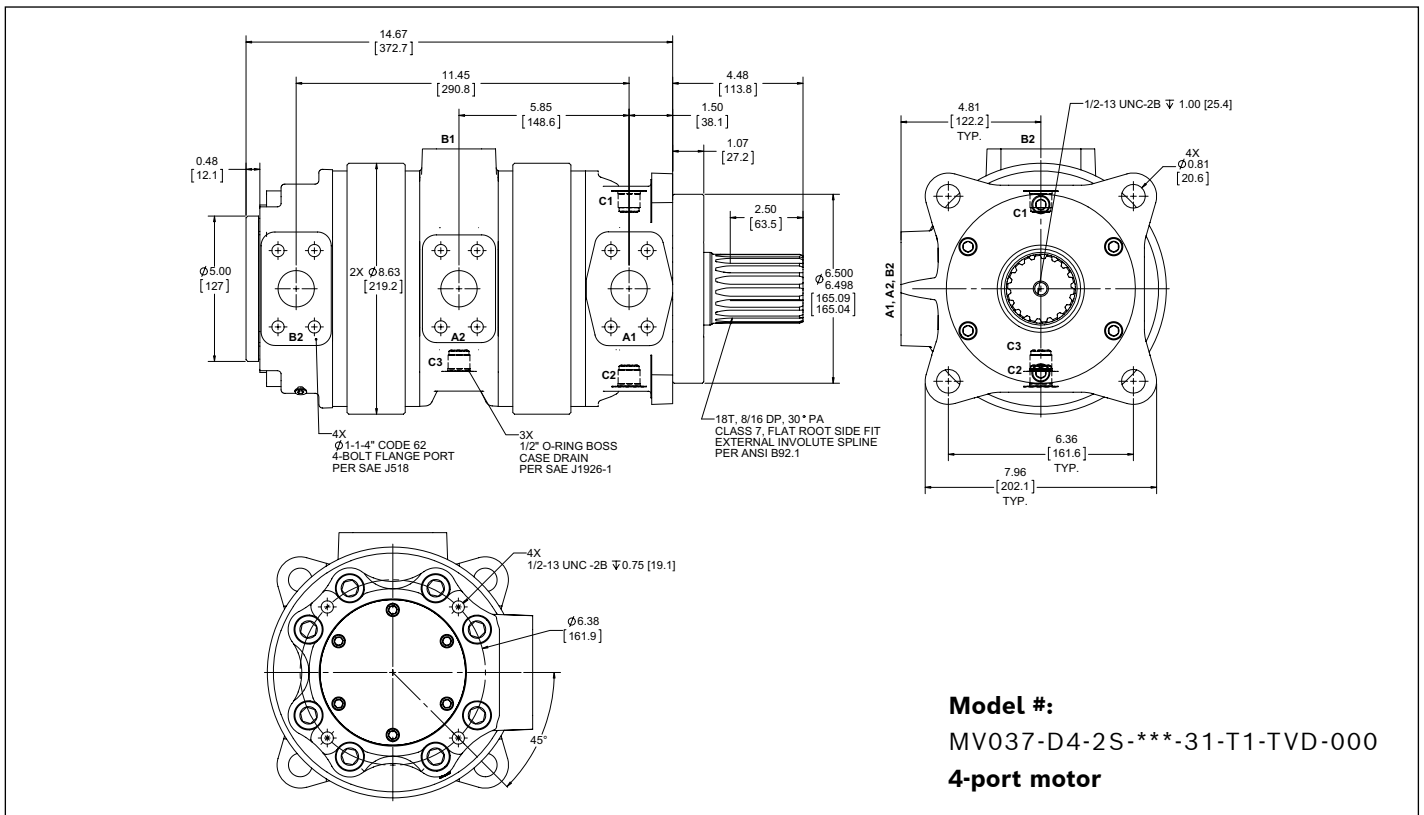
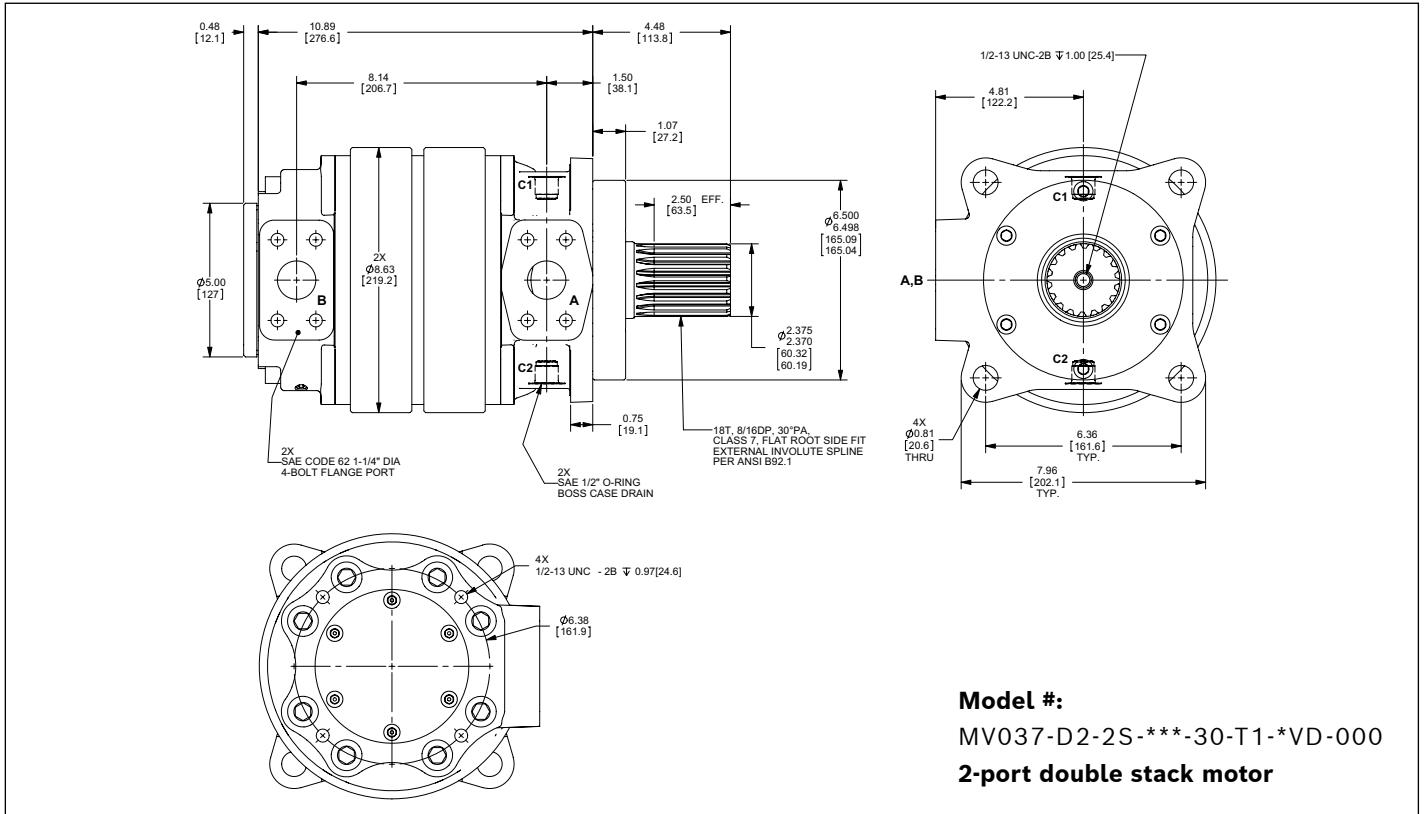

Unit dimensions

Code 62 (T1 bearing) – continued

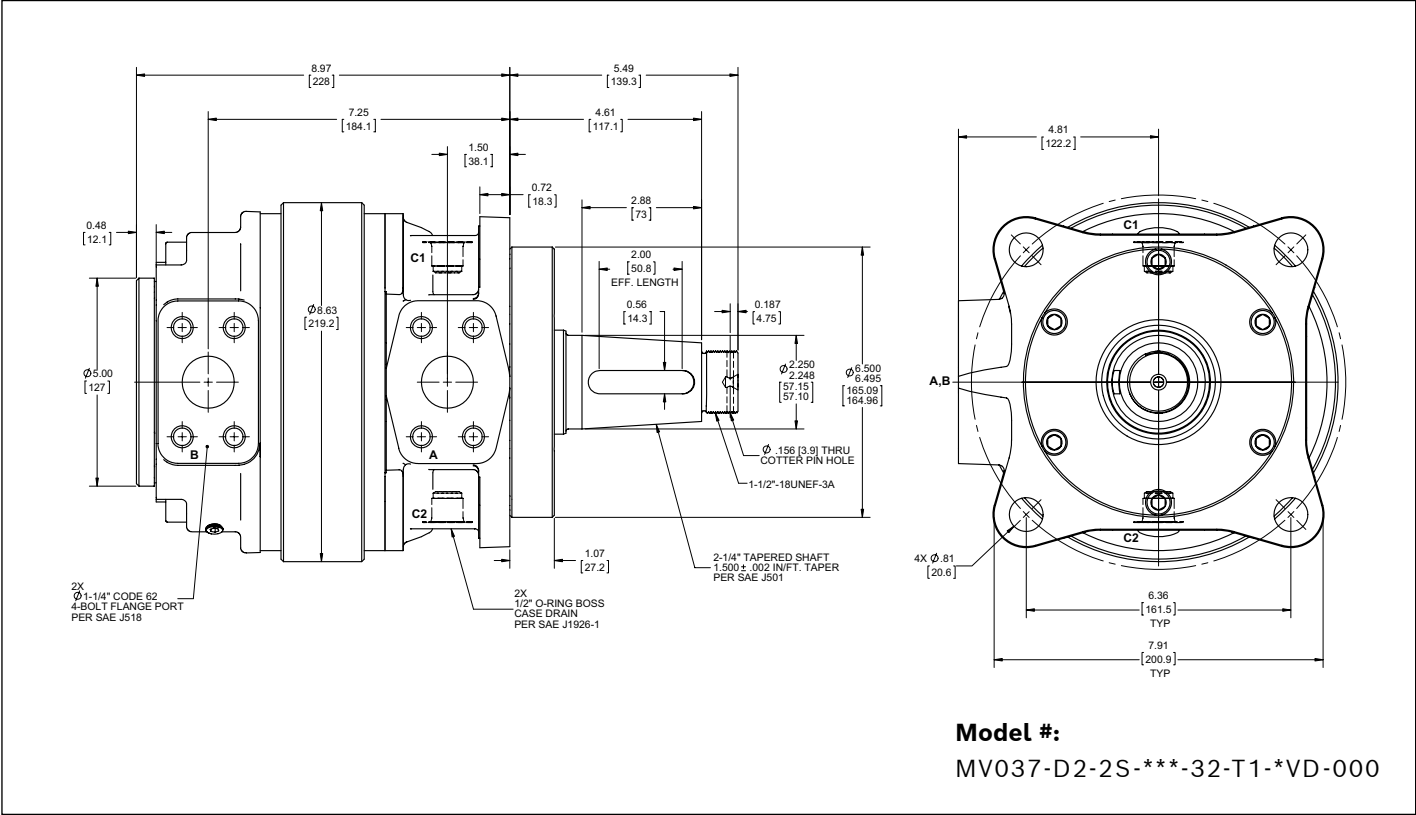

Model #: MV037-D2-2S-\*\*\*-32-T1-\*VD-000

### Unit dimensions

#### Code 62 (T4 bearing)

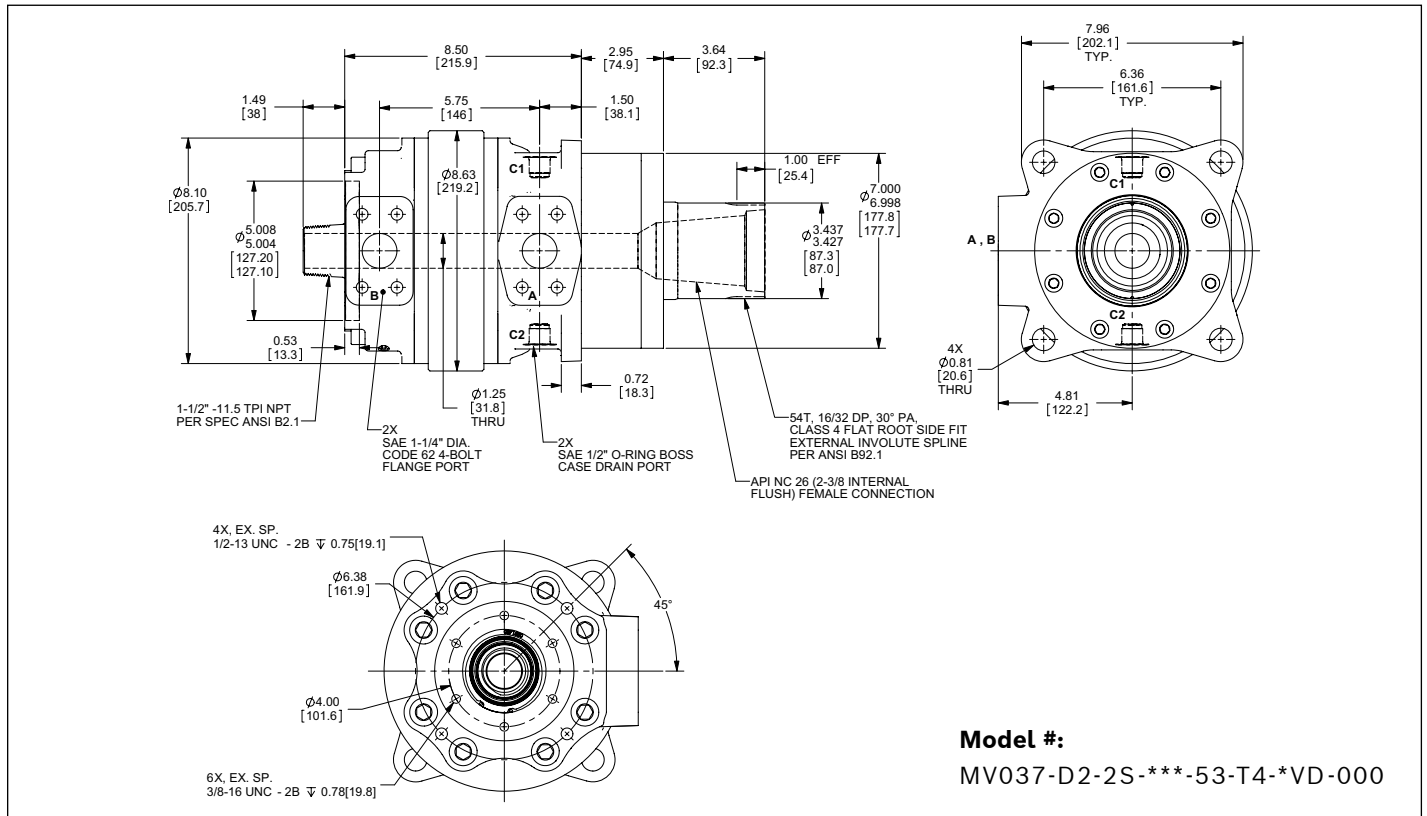

**Model #:**  
MV037-D2-2S-\*\*\*-53-T4-\*VD-000

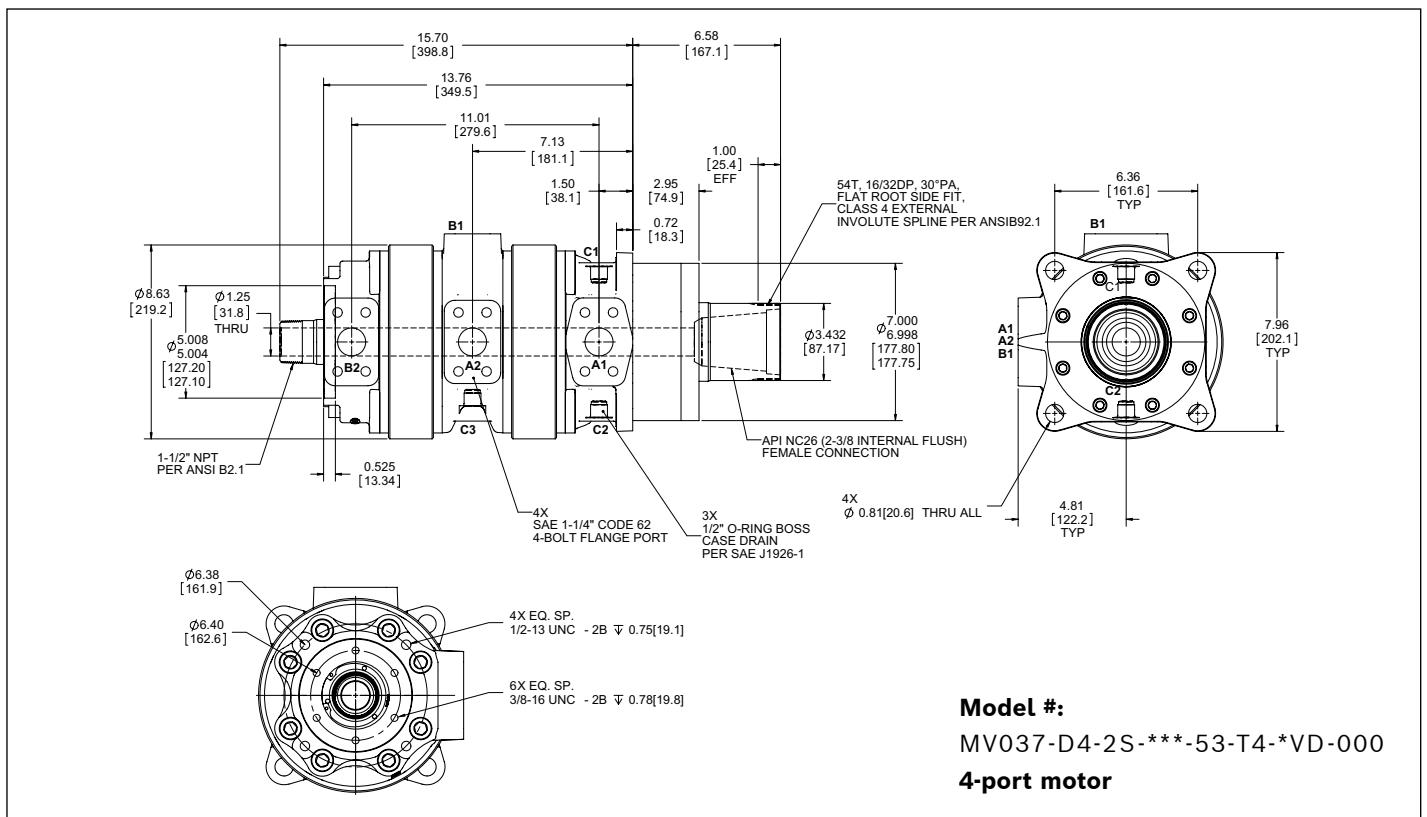

**Model #:**  
MV037-D4-2S-\*\*\*-53-T4-\*VD-000  
**4-port motor**

Unit dimensions

Code 62 (T5 bearing)

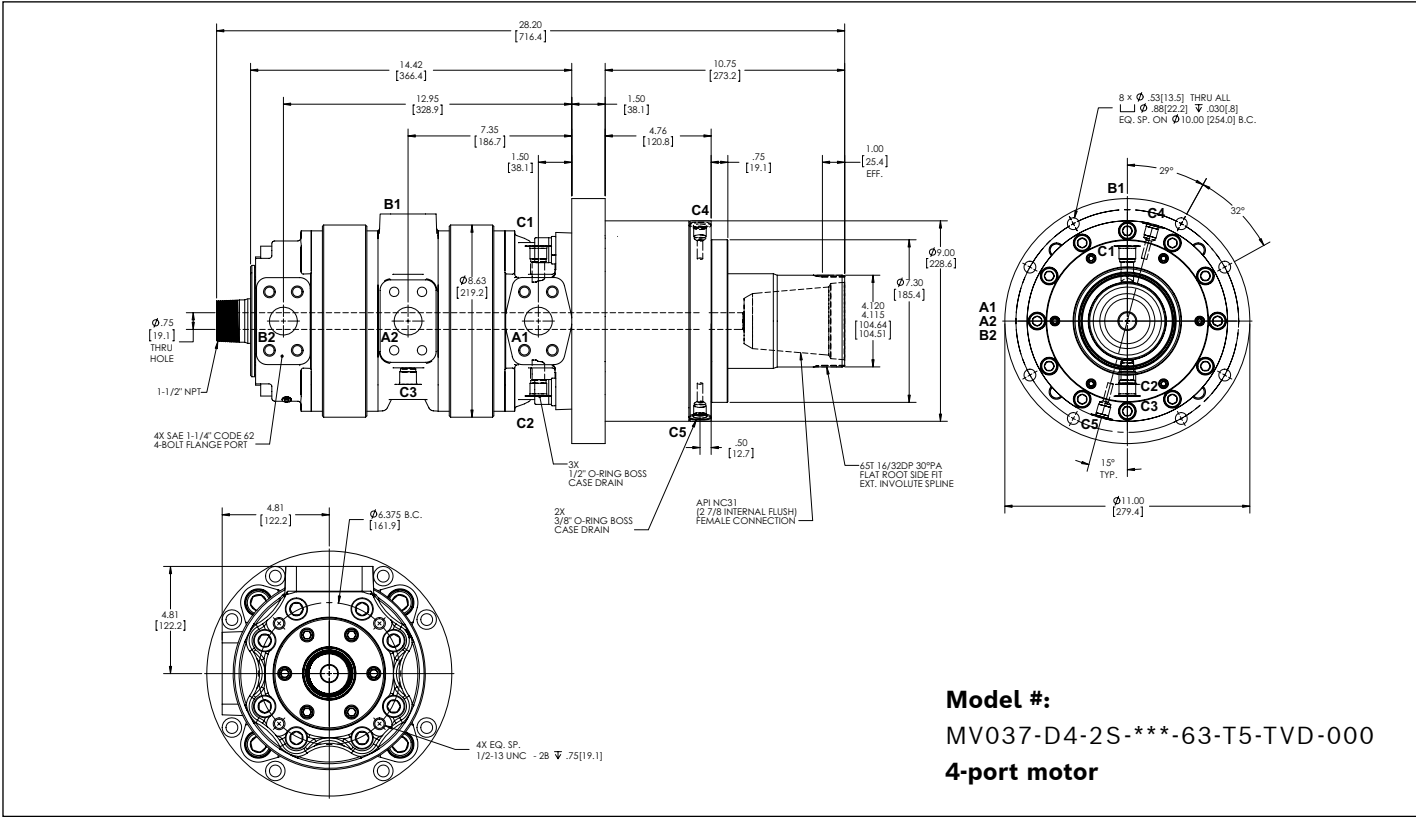

## Engineering guidelines

### Case Drain

The 37 Series motors **REQUIRE** an external case drain of sufficient size to prevent back pressure in excess of 35 psi (2.4 bar) for radial lip seals or 100 psi (6.9 bar) for quad seals. A case drain line must be run to the reservoir with minimum restriction as to not exceed the rated capacity of the seals; any unused case drain ports must be plugged. Never plug all case drain ports as this will cause build up of pressure in the motor case and blow out the shaft seal. The case drain line should return directly to the reservoir below the surface of the oil, and as far away as possible from the pump suction line. Refer to the unit drawings for case drain port locations. Use of the case drain port at the highest elevation is recommended.

### Thermal Shock

Consideration to cold temperature environments must be provided in the event that a temperature differential exists between the motor and the system in excess of 50 °F (28 °C). Contact a Bosch Rexroth Rineer representative if this is a possibility. In cold temperature environments it may be necessary to warm up the oil in the hydraulic system before the system is used. Typically the warm up is limited to the oil, the pump and directional control valve; leaving other components in the circuit such as the motor cold. When a directional control valve is shifted, the warm oil in the hydraulic system flows through a cold motor resulting in a non-uniform expansion of the internal parts of the motor which may lead to galling and component failure. Low pressure oil can be circulated through the motor case at a maximum flow rate of 3 gpm (11 lpm) or idled at low speed of 20 rpm maximum until the motor temperature is within 50 °F (28 °C) or less than system oil temperature.



## Engineering guidelines

### Circuit design

#### 2-port motor circuit

When fluid flow is provided to the “A” port, the rotation of the shaft as seen from its end will be clockwise. The “B” port will be return line flow. Using the “B” port for inlet

flow will simply reverse the direction of rotation of the shaft and the “A” port will become the return line port.

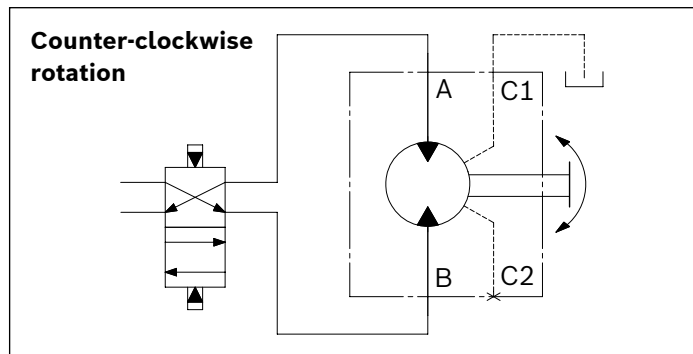
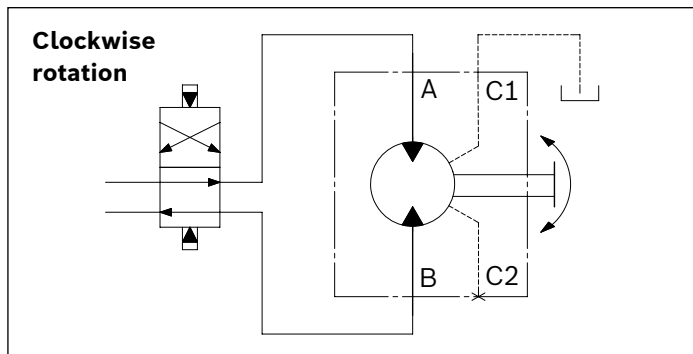

#### 4-port motor circuit

The front housing has a port designated “A1.” The center housing has 2 each ports designated “A2” and “B1”. Port “A2” is on the same plane as port “A1”. Port “B1” is offset from “A2” by 90 degrees. The rear housing has a port designated “B2” and is located on the same plane as “A1”

and “A2.” The 4-port motor is capable of single speed and with external valving, two speed operation. Two-speed operation with the 4-port motor can be accomplished using either series/parallel or logic circuits.

#### Series/parallel circuit

When using a series/parallel circuit with the 4-port motor, equal displacement rotating groups must be used. See the

circuit diagram below for reference only.

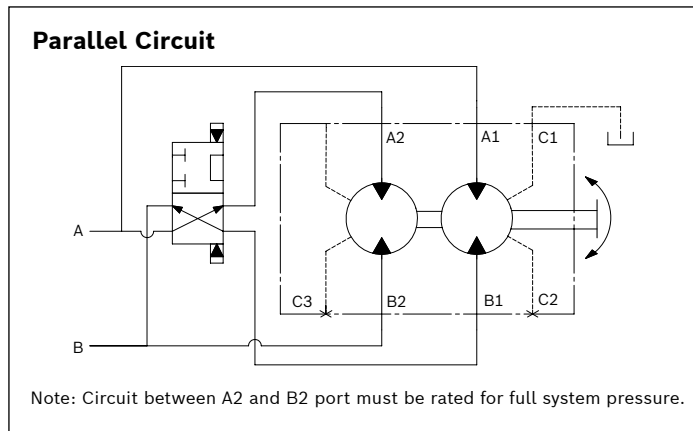
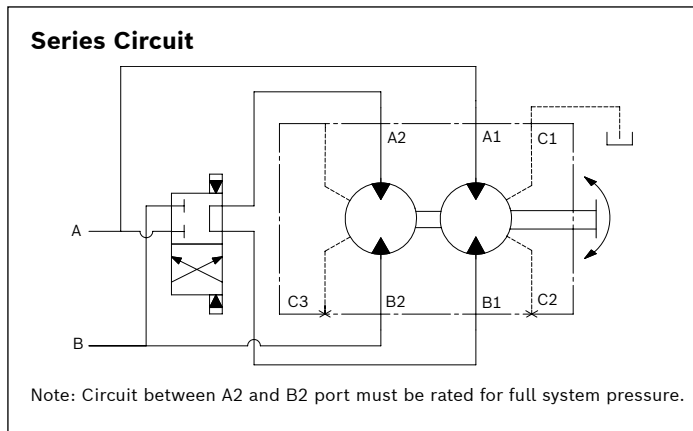

## Notes

A large grid of small dots, intended for taking notes. The grid consists of approximately 25 columns and 40 rows of dots, spaced evenly across the page.

**Notes**

A large grid of small dots, intended for taking notes. The grid consists of approximately 25 columns and 40 rows of dots, spaced evenly across the page.

**Bosch Rexroth Corp.**  
Hydraulics  
8 Southchase Court  
Fountain Inn, SC 29644-9018  
U.S.A.  
Telephone (864) 967-2777  
Facsimile (864) 967-8900  
[www.boschrexroth-us.com](http://www.boschrexroth-us.com)

© All rights reserved Bosch Rexroth Corp. This document, as well as the data, specifications and other information set forth in it, are the exclusive property of Bosch Rexroth Corp. It may not be reproduced or given to third parties with its consent.

The data specified above only serve to describe the product. No statements concerning a certain condition or suitability for a certain application can be derived from our information. The information given does not release the user from the obligation of own judgment and verification. It must be remembered that our products are subject to a natural process of wear and aging.