

High Torque Radial Piston Motors MRD and MRV Type

Dual and variable displacement (up to 7000 cm³/rev)

Conversion factors

1 kg	2.20 lb
1 N	0.225 lbf
1 Nm	0.738 lbf ft
1 bar	14.5 psi
1 l	0.264 US gallon
1 cm ³	0.061 cu in
1 mm	0.039 in
1 °C	(5/9)(°F-32)
1 kW	1.34 hp

Conversion factors

1 lb	0.454 kg
1 lbf	4.448 N
1 lbf ft	1.356 Nm
1 psi	0.068948 bar
1 US gallon	3.785 l
1 cu in	16.387 cm ³
1 in	25.4 mm
1 °F	(9/5)(°C) + 32
1 hp	0.7457 kW

**WARNING – USER RESPONSIBILITY**

This document and other information from Calzoni Hydraulics provide product or system options for further investigation by users having technical expertise.

The user, through its own analysis and testing, is solely responsible for making the final selection of the system and components and assuring that all performance, endurance, maintenance, safety and warning requirements of the application are met. The user must analyze all aspects of the application, follow applicable industry standards, and follow the information concerning the product in the current product catalog and in any other materials provided from Calzoni Hydraulics.

To the extent that Calzoni Hydraulics provide component or system options based upon data or specifications provided by the user, the user is responsible for determining that such data and specifications are suitable and sufficient for all applications and reasonably foreseeable uses of the components or systems.

Content	Page
General information	4
Functional description	6
Technical data	10
Ordering information	12
Overall dimensions	16
Hydraulic fluids	29
Operating diagrams.....	31
Installation and commissioning notes	46
Service life and motor selection.....	50

General Information

Calzoni MRD (dual displacement) and MRV (continuously variable displacement) hydraulic motors are of the radial piston type. Unique Fluid Column Technology is utilized to achieve superior performances compared to competitive designs. The motors are engineered for high mechanical and volumetric efficiency over a wide range of speed and torque.

Due to their special design, the MRD/MRV motors deliver their maximum performance when the application requires high torque values. The MRD/MRV motors combine precise and smooth movements, both at low speed and during acceleration and deceleration transitions.

In addition, the high starting torque (up to 96%) allows the user to select a smaller displacement of the motor, optimizing the size of all the other system's components.

Other typical characteristics of MRD/MRV motors are:

- high power to weight ratio
- high volumetric and mechanical efficiency
- high resistance to thermal shock
- very low operating noise levels
- suitable for fire-resistant and biologically degradable fluids
- extremely well suited for control engineering applications
- reversible operation (motor and pump)

MRD/MRV motors are grouped into 8 different frame sizes, with the possibility to customize both maximum and minimum displacement values to suit specific application requirements.

Motors can be customized by selecting different types of shafts, speed sensors, seals, and connection flanges.

Optional accessories include gearboxes and parking brakes.

Furthermore, MRD/MRV motors can be equipped with optional built-on manifold blocks (cross relief, anti-cavitation, flushing and drain valves) to suit the customer needs.

To ensure high quality production standards, we maintain a Quality Assurance System, certified to standard ISO 9001:2015, ISO 14001:2015, ISO 45001:2018

The product has been approved by ABS for use on ABS classed vessels..

ATEX version is available for use in potentially explosive atmospheres (Directive 2014/34/EU).

Hydraulic symbols

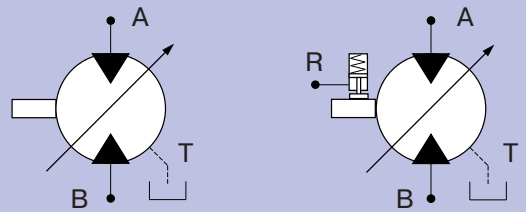

Motor without brake

Motor with brake

Hydraulic motor	
Construction	Dual and variable displacement radial piston motors, fluid column type
Mounting type	Flange
Maximum pressure	Up to 420 bar (6000 psi) ⁽¹⁾
Displacement	Up to 7'000 cm ³ /rev (425 in ³ /rev)
Torque	Up to 32'000 Nm (23'600 lbf-ft)
Temperature range	-30 to +80 °C (-22° to +176°F)
Direction of rotation	Reversible (clockwise / counterclockwise)
Operation type	Reversible (motor and pump) ⁽²⁾
⁽¹⁾ = Peak value, see operating diagrams for complete motor parameters; ⁽²⁾ = Charge pressure is required during pumping operation (refer to "Operating diagrams" section).	

Examples of installations

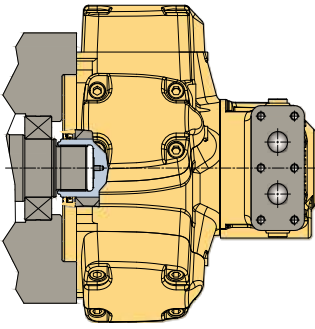

Flange mounted motor

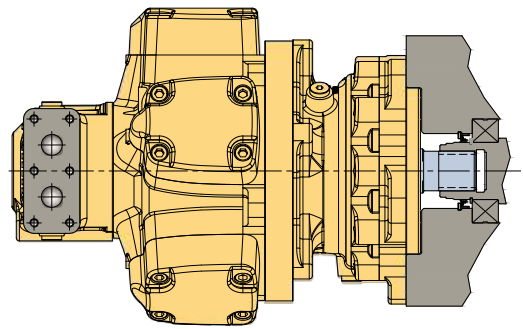

Flange mounted motor
with parking brake

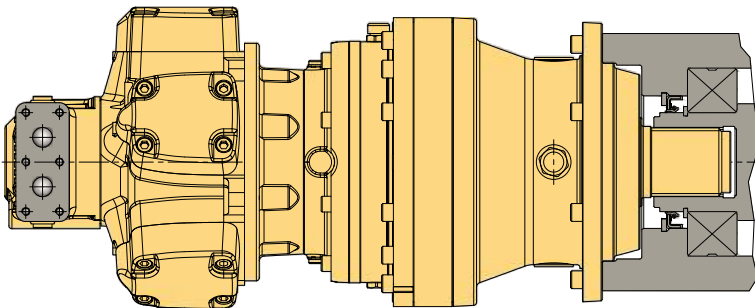

Flange mounted motor with gearbox and parking brake

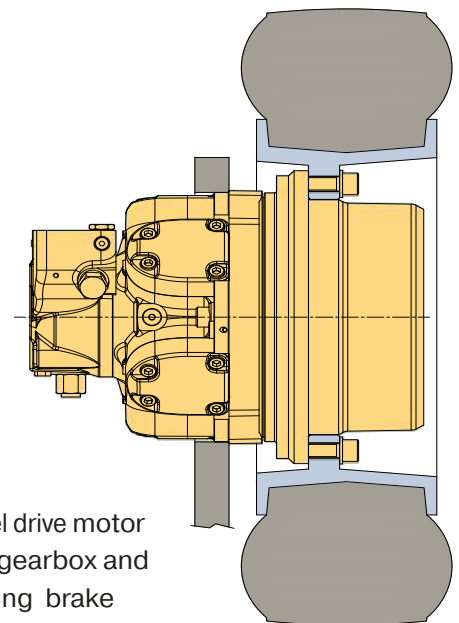

Wheel drive motor
with gearbox and
parking brake

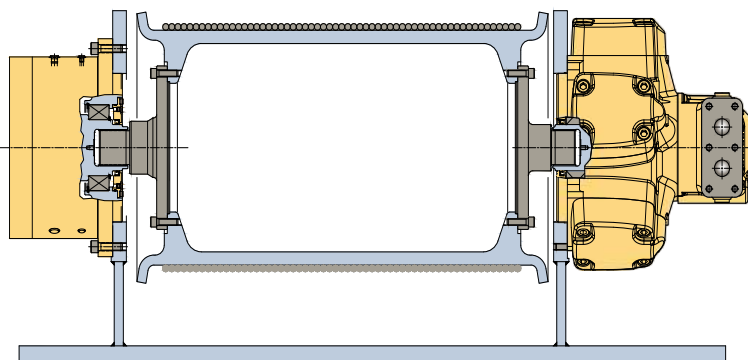

Direct mounted winch drum drive with parking brake

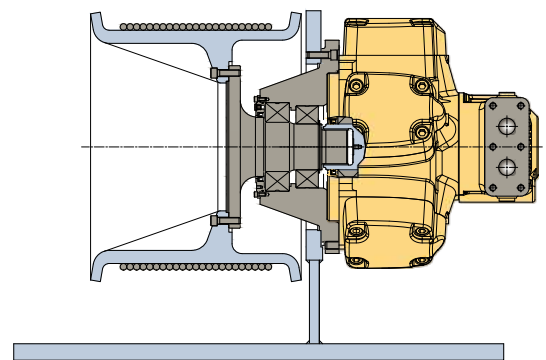

Bracket mounted capstan drive

Propulsion: “The fluid column technology”

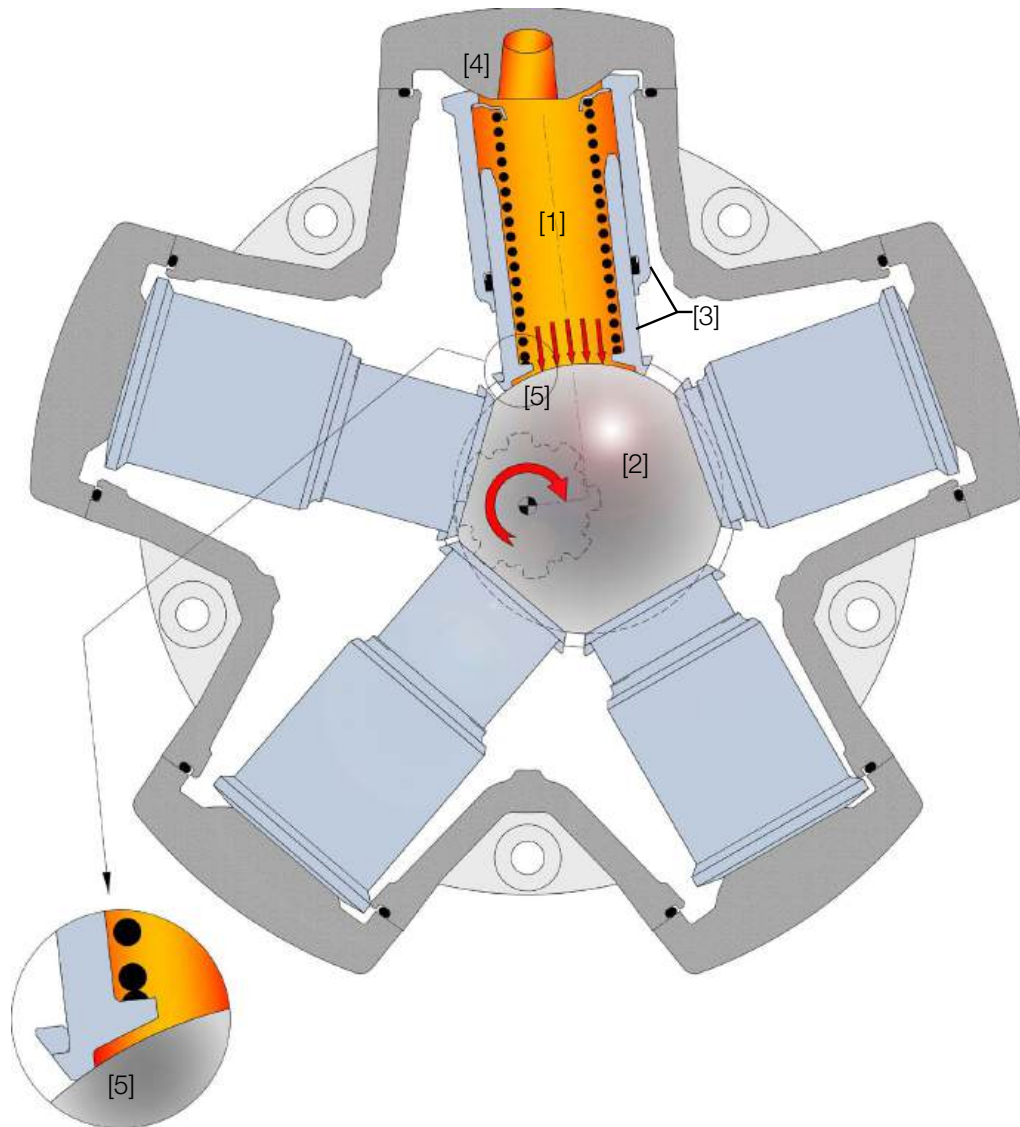

The main concept of this unique and outstanding technology is to convert fluid power (pressure and flow) into mechanical power (torque and speed) by means of pressurized columns of fluid [1] which act directly on a spherical eccentric shaft [2], thereby avoiding the use of conventional connecting rods, pistons, and pins.

Torque is generated by the columns of pressurized fluid [1] that directly push the eccentric cam [2] producing the shaft rotation.

In each propulsion unit, the pressurized fluid is contained within a telescopic cylinder [3] that is sealed by two spherical surfaces, one on the propulsion cover [4] and one on the eccentric shaft [5]. The two spherical surfaces guide the telescopic cylinder so that no side forces are generated during the shaft rotation.

Thanks to the limited friction and wear caused by the “metal to metal” contact, the fluid column propulsion system guarantees high values of volumetric and mechanical efficiency, combined with smooth and precise movements of the motor shaft, even at the lowest speeds.

Timing system: “The balanced forces concept”

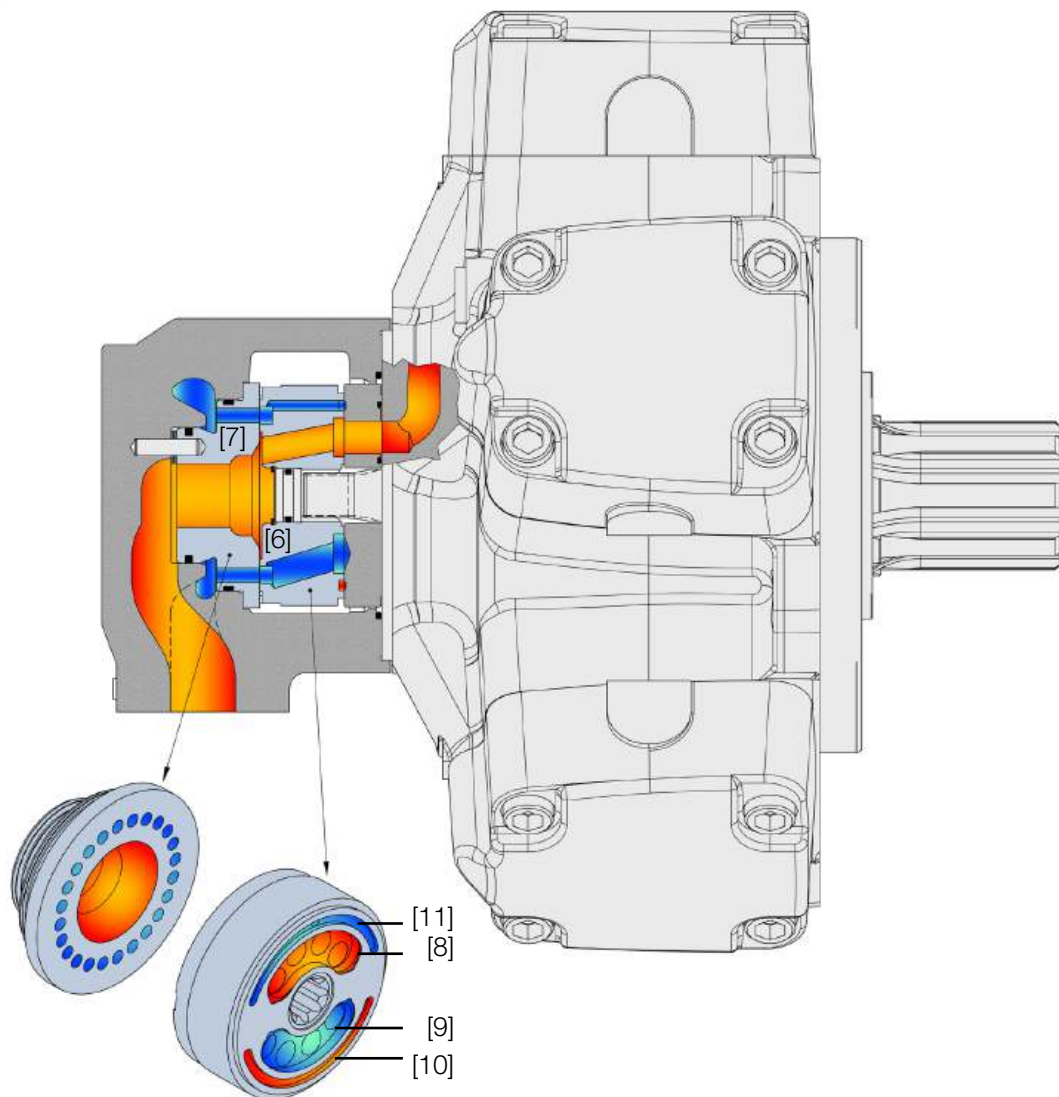

The timing system - consisting of the rotary valve [6] and the reaction ring [7] - supplies the columns of fluid precisely in the correct sequence to generate a smooth motor output torque. While the reaction ring is used to adjust the clearance and to compensate for thermal shocks, the rotary valve rotates at the same speed as the eccentric shaft and connects the reaction ring to the piston chambers by means of two slots [8] and [9]. Two additional balancing slots [10] and [11] cancel the tilting moments (patented), guaranteeing consistent performance for the entire service life.

Product philosophy: “Design for performance and durability”

The human intelligence has always been applied to design mechanisms in which the movements and forces are the result of different components working together providing stresses and strains against each other. Our product philosophy has allowed us to achieve the balancing of each of these movements, making our motors more efficient and resistant to wear and tear over time.

Newton’s Third Law

“For every action, there is an equal and opposite reaction”: inside our motors, we hydraulically transmit and balance forces to generate high torque values combined with low friction and high efficiency.

MRD displacement control technology

The MRD series dual displacement models have two pre-set displacements which can be chosen from a wide range to suit specific application requirements. The change of displacement can take place in motion, guaranteeing reliability and high performances of the entire circuit.

The motors displacement can be modified by means of displacement control pistons [1] that act on the spherical cam [2], changing its eccentricity and varying the motor displacement.

A three way shuttle valve [3] (available with internal piloting configuration) selects the higher between A and B main port pressures, while a two position / four way directional control valve [4] is used to energize the displacement control pistons [1] and change the motor displacement from maximum to minimum and vice-versa. Intermediate displacements cannot be obtained with this control.

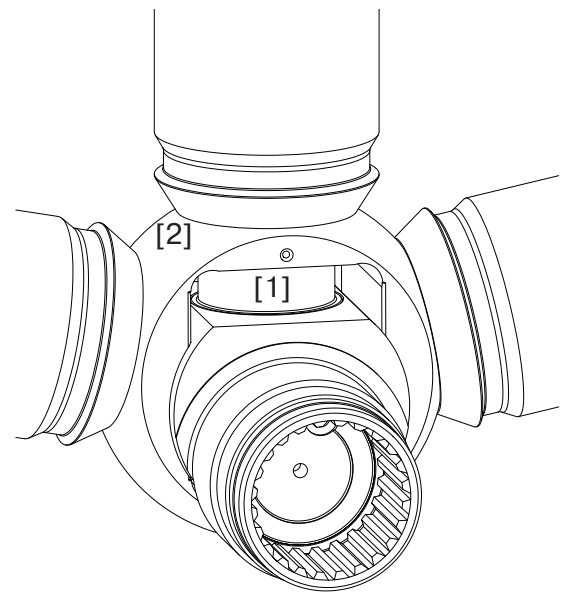
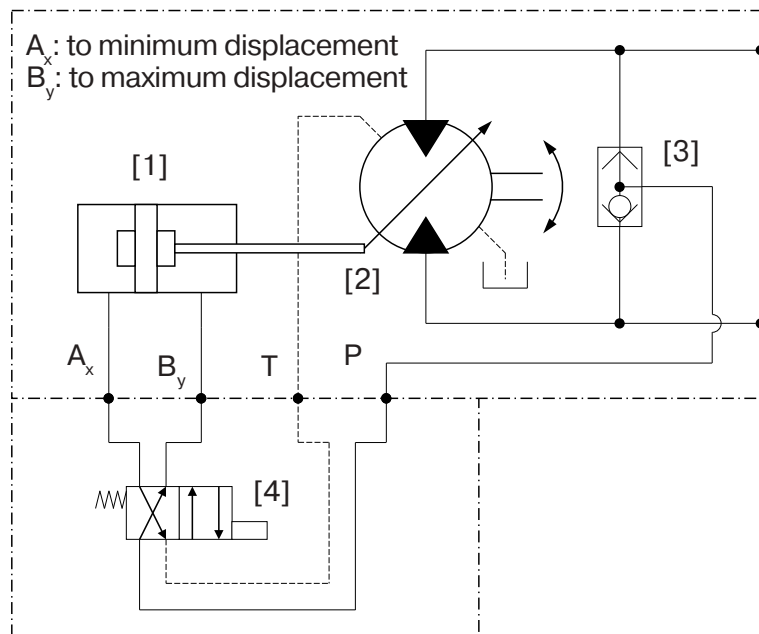

MRV displacement control technology

The MRV series variable displacement models have the additional capability to lock the displacement at any intermediate value in between the maximum and the minimum. This feature is obtained by means of a dual pilot operated check valve [5] assembled on the motor: when the three position / four way directional control valve [6] operates in neutral position, the displacement value is locked at the current position thanks to the fluid sealed inside the displacement control pistons due to the dual pilot check valve.

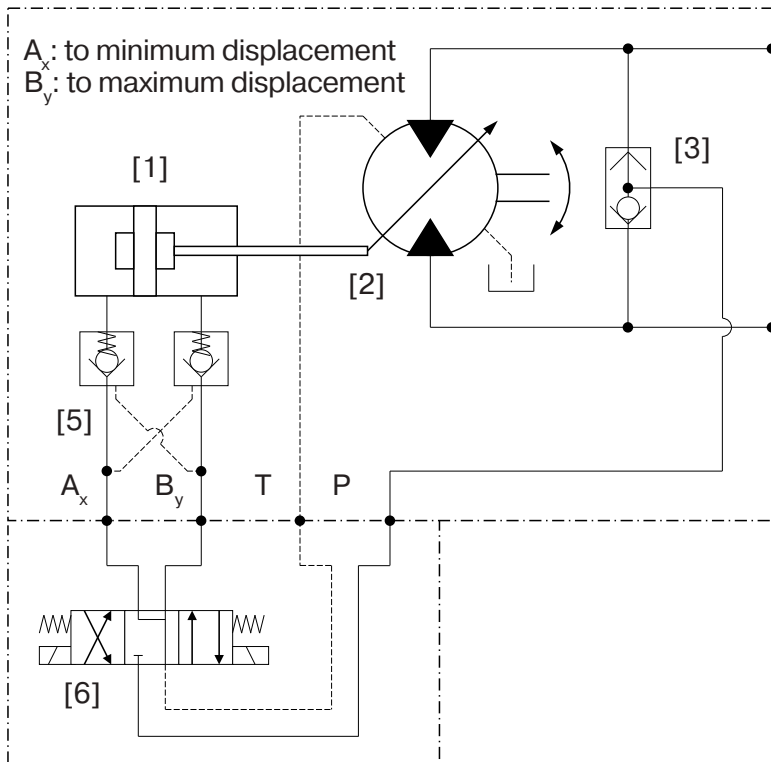

The fully variable displacement technology of the MRV motor series allows the users to extend the operating range of the machine both in terms of drive torque and speed, guaranteeing high efficiency values of the whole system both at “high torque / low speed” than at “low torque / high speed”.

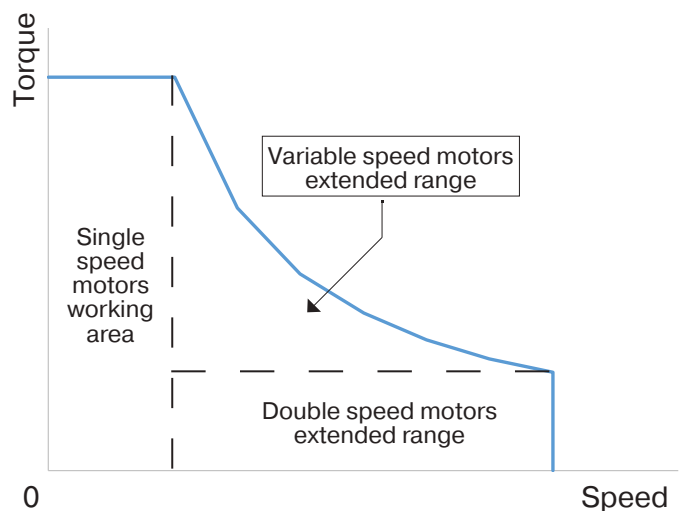

Calculation fundamentals

$$\text{Required flow: } Q = \frac{V \times n}{1000 \times \eta_v} \quad (\text{l/min})$$

$$\text{Output torque: } M = \frac{V \times \Delta p \times \eta_m}{62.8} = T_s \times \Delta p \quad (\text{N.m})$$

$$\text{Output power: } P = \frac{Q \times \Delta p \times \eta_t}{600} = \frac{M \times n}{9549} \quad (\text{kW})$$

V = displacement (cm³/rev)
 n = speed (rpm)
 T_s = specific torque (Nm/bar)
 Δp = differential pressure (bar)
 η_v = volumetric efficiency
 η_m = mechanical efficiency
 η_t = overall efficiency

Technical data

Motor type	Displacement(*)		Specific torque	Speed		Maximum pressure				Maximum power	Weight
				Min	Max	Continuous	Intermittent	Peak	A+B		
-	V		T _s	n _{min}	n _{max}	p _{cont.}	p _{nit.}	p _{peak}	p _{A+B}	P _{max}	m
-	cm ³ /rev		Nm/bar	rpm	rpm	bar	bar	bar	bar	kW	kg
MRD 300 D 150	Min.	152.1	2.42	1	1000	250	300	420	400	35	56
	Max.	304.1	4.80	1	750	250	300	420	400	53	
MRDE 330 D 165	Min.	166.2	2.65	1	1000	210	250	350	400	32	56
	Max.	332.4	5.30	1	750	210	250	350	400	49	
MRD 450 E 225 MRV 450 E 225	Min.	225.8	3.60	1	850	250	300	420	400	45	85
	Max.	451.6	7.20	1	600	250	300	420	400	75	
MRDE 500 E 250	Min.	248.9	3.96	1	800	210	250	350	400	38	85
	Max.	497.9	7.93	1	600	210	250	350	400	70	
MRD 700 F 240	Min.	237.6	3.80	1	750	250	300	420	400	45	105
	Max.	709.9	11.30	1	500	250	300	420	400	97	
MRDE 800 F 270 MRVE 800 F 270	Min.	270.2	4.27	1	750	210	250	350	400	40	105
	Max.	804.2	12.81	1	450	210	250	350	400	93	
MRD 1100 G 380 MRVE 1100 G 380	Min.	381.3	6.10	0.5	600	250	300	420	400	54	140
	Max.	1125.8	17.90	0.5	330	250	300	420	400	119	
MRDE 1400 G 464 MRVE 1400 G 464	Min.	463.9	9.85	0.5	550	210	250	352	400	55	140
	Max.	1369.5	21.80	0.5	280	210	250	350	400	105	
MRD 1800 H 600 MRV 1800 H 600	Min.	603.2	9.60	0.5	450	250	300	420	400	69	209
	Max.	1809.6	28.80	0.5	250	250	300	420	400	157	
MRDE 2100 H 700 MRVE 2100 H 700	Min.	697.0	16.65	0.5	420	210	250	350	400	72	209
	Max.	2091.2	33.30	0.5	250	210	250	350	400	148	

(*) = Both maximum and minimum displacement values can be customized to suit specific application requirements. Please contact Calzoni for the available options.

Motor type	Displacement(*)		specific torque	Speed		maximum pressure				Maximum power	Weight
				Min	Max	Continuous	Intermittent	Peak	A+B		
-	V		T_s	n_{min}	n_{max}	$p_{cont.}$	$p_{nit.}$	p_{peak}	p_{A+B}	P_{max}	m
-	cm ³ /rev		Nm/bar	rpm	rpm	bar	bar	bar	bar	kW	kg
MRD 2800 I 930 MRV 2800 I 930	Min.	930.7	14.80	0.5	320	250	300	420	400	80	325
	Max.	2792.0	44.50	0.5	215	250	300	420	400	194	
MRDE 3100 I 1030 MRVE 3100 I 1030	Min.	1034.6	24.71	0.5	300	210	250	350	400	85	325
	Max.	3103.7	49.40	0.5	215	210	250	350	400	190	
MRD 4500 L 1560 MRV 4500 L 1560	Min.	1560.0	24.80	0.5	280	250	300	420	400	85	508
	Max.	4502.7	71.70	0.5	170	250	300	420	400	210	
MRDE 5400 L 1870 MRVE 5400 L 1870	Min.	1870.0	29.8	0.5	250	210	250	350	400	100	508
	Max.	5401.2	86.01	0.5	160	210	250	350	400	210	
MRD 7000 M 2280	Min.	2280.0	36.30	0.5	210	250	300	420	400	125	812
	Max.	6967.2	110.94	0.5	130	250	300	420	400	250	

(*) = Both maximum and minimum displacement values can be customized to suit specific application requirements. Please contact Calzoni for the available options.

Definitions and guidelines

- Continuous pressure ($p_{cont.}$): Maximum pressure during continuous working operations.
- Intermittent pressure ($p_{int.}$): Maximum pressure during non-continuous operations (intermittent pressure may occur max 10 % of duty cycle and not more than 20 consecutive seconds inside each cycle).
- Peak pressure (p_{peak}): Pressure exceeding the maximum operating pressure for a short time at which the motor remains able to function (milliseconds corresponding to the reaction time of the system relief valve).
- Additional pressure (p_{A+B}): Maximum sum of inlet pressure and outlet pressure.

Due to its high volumetric efficiency, the motor case must be flushed when the output power exceeds 70 % of the maximum admitted value $P_{max.}$, in order to assure the minimum oil viscosity inside the motor case of 30 cSt. The flushing is necessary also when the requested minimum viscosity condition is not assured.

Ordering codes

E.g.: **MRD 1100 G 500** — **D1** **B1** **N1** **G1** **N** **B** (*)

Code	Description
MRD	Dual displacement motor
MRV	Variable displacement motor

Code	Description
N1	NBR mineral oil 5 bar shaft seal
F1	NBR mineral oil, 15 bar shaft seal (not available in case of brake assembly)
U1	No shaft seal (for brake coupling)
V1	FPM (Viton®)

Code(**)	Description
N1	Six-bolt connection (for manifold blocks)
S1	Standard pressure SAE metric adaptor
T1	Standard pressure SAE UNC adaptor
G1	High pressure SAE metric flange (6000 psi)
L1	High pressure SAE UNC flange (6000 psi)
C1	BSP threads flange (according to ISO 228/1)

Code	Description
-	None
B	Parking brake

Code(**)	Description
N1	Splined male shaft, according to standard DIN 5463
D1	Splined male shaft, according to standard DIN 5480
F1	Splined female shaft, according to standard DIN 5480
P1	Male shaft with key
B1	Splined male shaft, according to standard BS 3550

Code	Description
N1	None
C1	Connection for mechanical tachometer
Q1	Connection for encoder
T1	Connection for tachogenerator
M1	Monodirectional incremental encoder
B1	Bidirectional incremental encoder

Code	Inlet Port	Direction of rotation (viewed from shaft end)
N	A	Clockwise
	B	Counter-clockwise
S	B	Clockwise
	A	Counter-clockwise

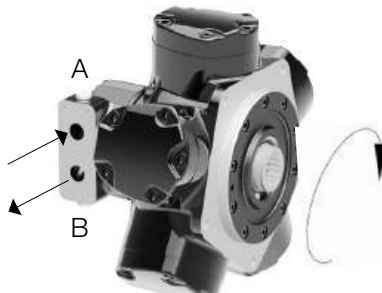

To be selected from pages 10 - 11; for customization of max./min. displacement please contact Calzoni.

(*) = Space reserved to Calzoni Hydraulics

(**) = Please refer to the indicated pages for codes actually available for each frame size. Some of the options are not available for all frame sizes. In case of brake assembly, standard shaft codes available are N1-F1-D1.

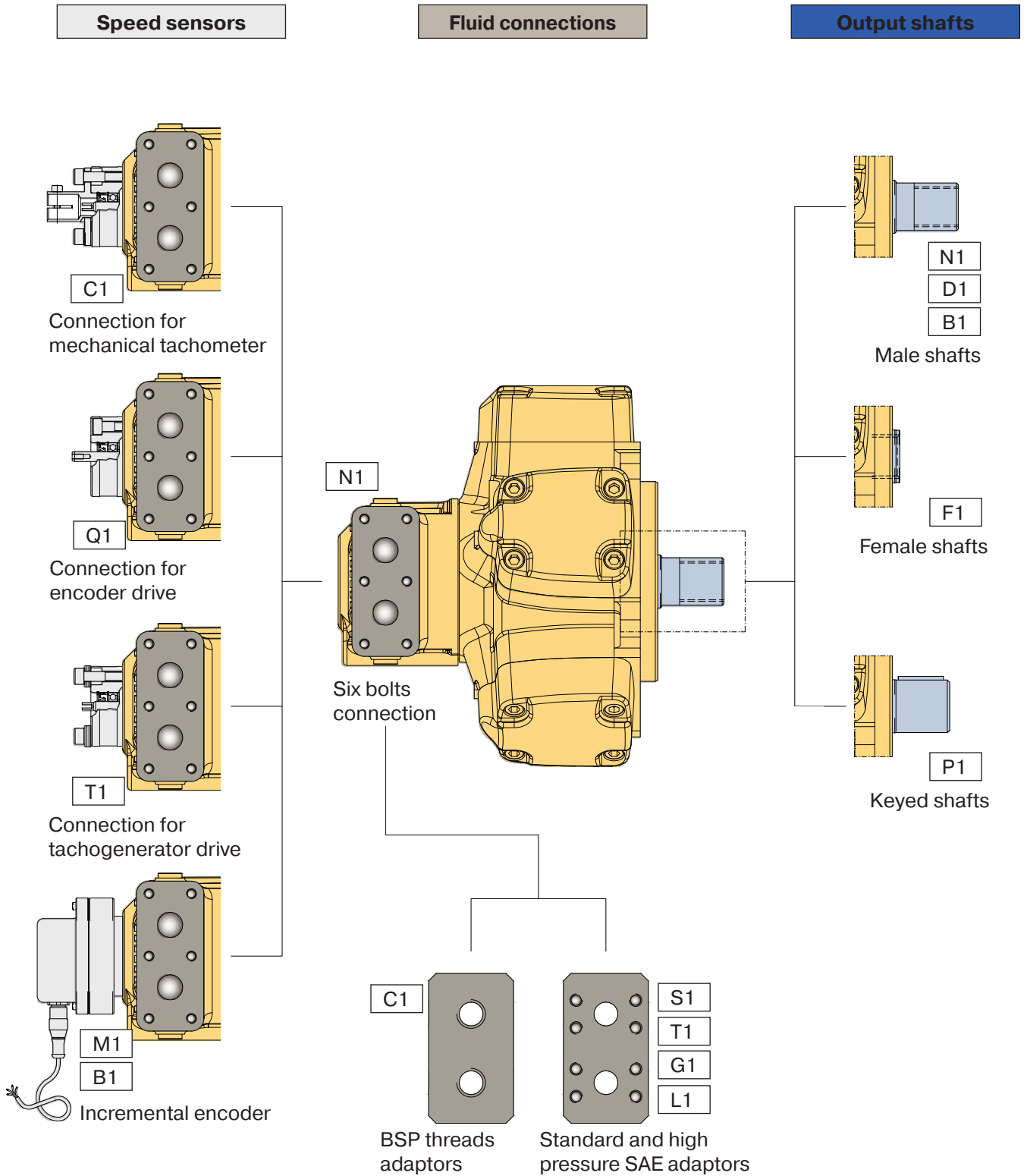

Main dimensions

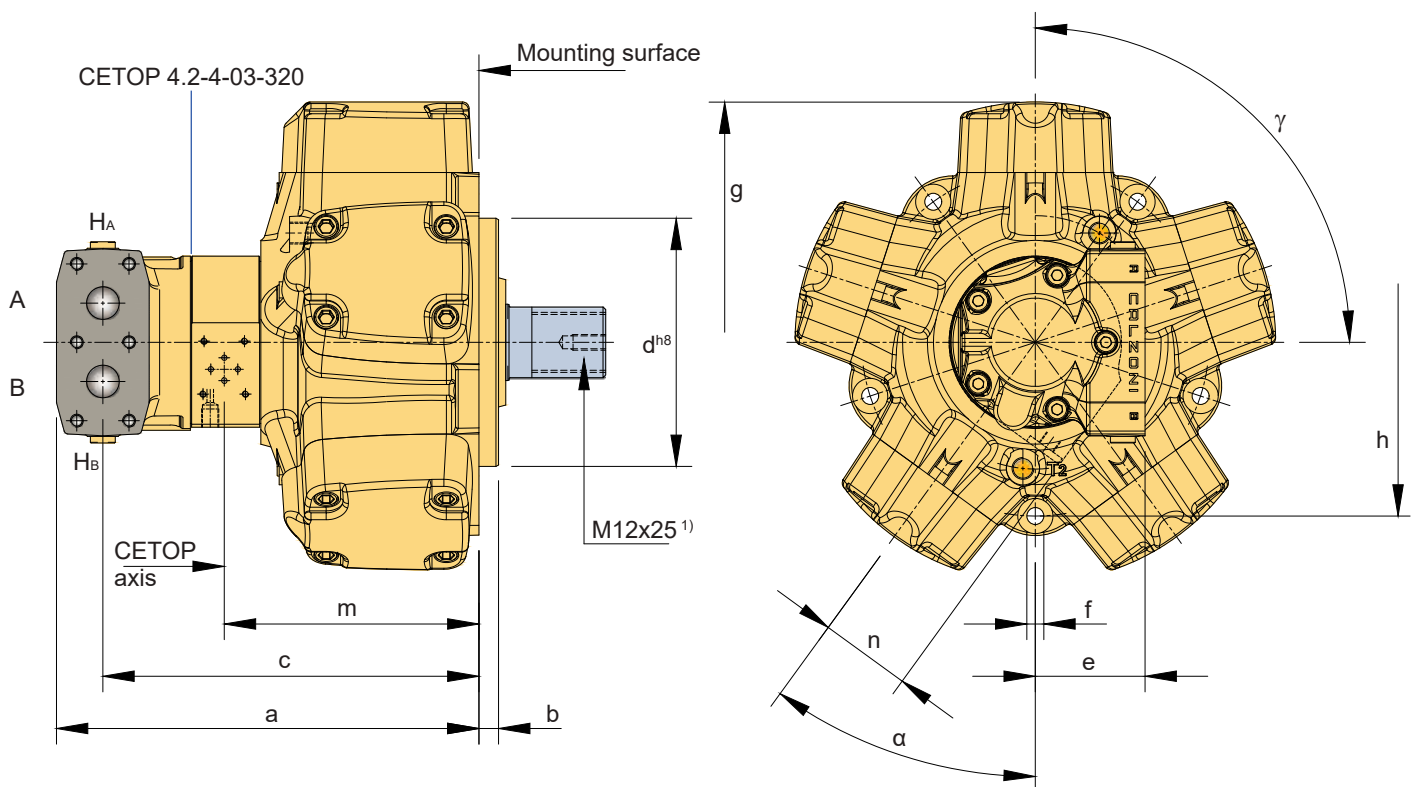

HA, HB = Port 1/4" BSP threads to ISO 228/1 for pressure reading.

1) The shaft threaded holes must be considered as service holes. In case the holes dimensions required by the application are different from the ones listed here above, please contact the manufacturer (option on request).

MOTOR TYPE	a	b	c	d	e	f	g	h	m	n	T1, T2	γ	α
MRD 300 D MRDE 330 D	295	15	257	175	72	11	328	232	173	70	G 3/8	90°	0°
MRD 450 E MRV 450 E MRDE 500 E	323.5	15	288	190	84	13	368	266	195	70	G 3/8	90°	0°
MRD 700 F MRV 700 F MRDE 800 F MRVE 800 F	343.5	15	308	220	84	13	405	290	215	70	G 3/8	90°	0°
MRD7000M	626	37	555	450	123	25	864	600	417	108	G 1/2	108°	18°

Main dimensions

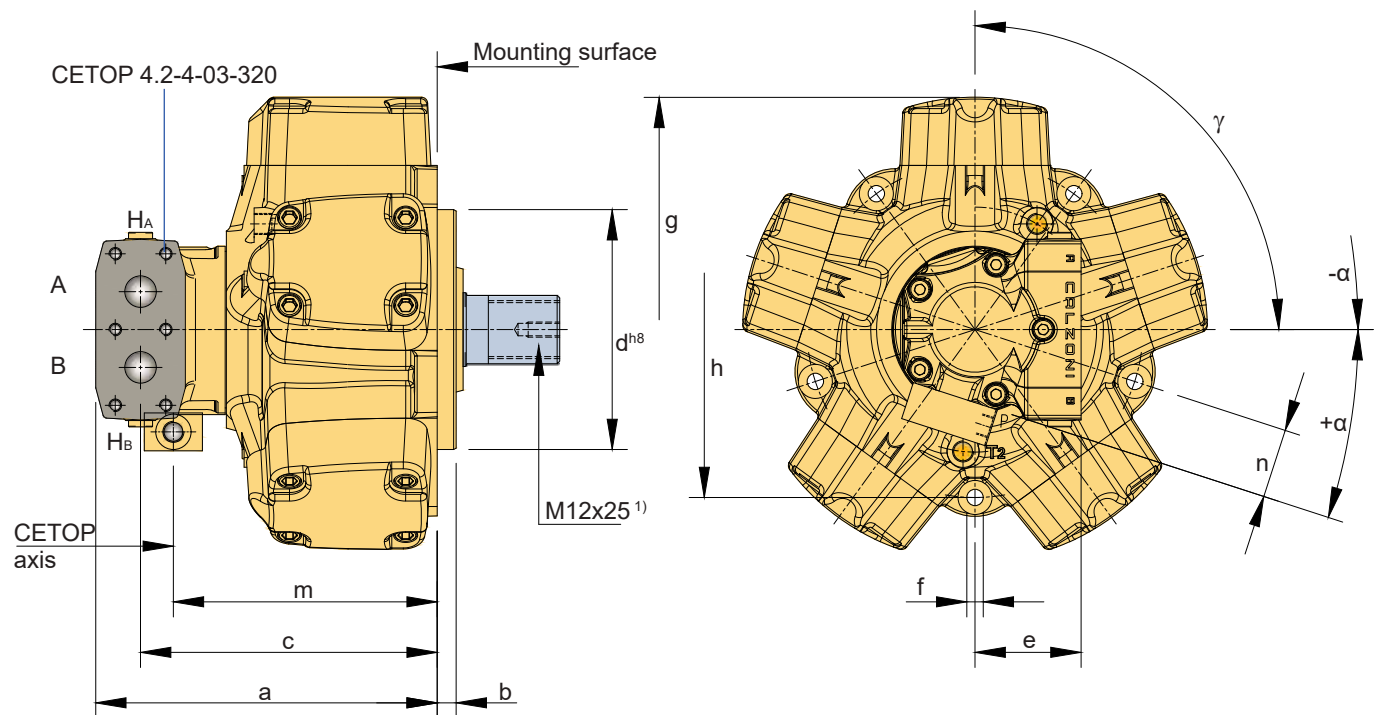

HA, HB = Port 1/4" BSP threads to ISO 228/1 for pressure reading.

¹⁾ The shaft threaded holes must be considered as service holes. In case the holes dimensions required by the application are different from the ones listed here above, please contact the manufacturer (option on request).

MOTOR TYPE	a	b	c	d	e	f	g	h	m	n	T1, T2	γ	α
MRD 1100 G MRVE 1100 G MRDE 1400 G MRVE 1400 G	341	20	293	250	105	15	470	330	278	83	G 1/2	104°	14°
MRD 1800 H MRV 1800 H MRDE 2100 H MRVE 2100 H	374	21	326	290	105	17	558	380	311	83	G 1/2	90°	0°
MRD 2800 I MRV 2800 I MRDE 3100 I MRVE 3100 I	466	24	392	335	123	19	642	440	390	95	G 1/2	90°	-30°
MRD 4500 L MRV 4500 L MRDE 5400 L MRVE 5400 L	489.5	34	418,5	400	123	23	766	540	413.5	95	G 1/2	108°	-12°

Male shafts

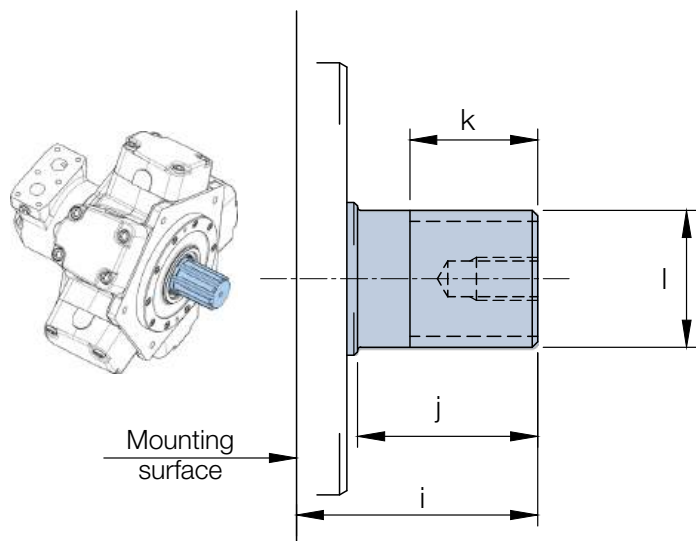

Code	Output shaft
N1	Splined male shaft, according to standard DIN 5463
D1	Splined male shaft, according to standard DIN 5480
B1	Splined male shaft, according to standard BS 3550

MOTOR TYPE	Option code "N1" (standard DIN 5463)		Option code "D1" (standard DIN 5480)		Option code "B1" (standard BS 3550)			
	i	j	k	l	k	l		
MRD 300 D	81	60	46	B8x42x48	45	W48x2x22-8e	46	12/24-21
MRDE 330 D	[3.19]	[2.36]	[1.81]		[1.77]		[1.81]	
MRD 450 E	97	74	56.5	B8x46x54	61	W55x3x17-8e	60	8/16-17
MRDE 500 E	[3.82]	[2.91]	[2.22]		[2.40]		[2.36]	
MRV 450 E								

Measures in millimeters [inches in brackets]

MOTOR TYPE	i	j	Option code "N1" (standard DIN 5463)		Option code "D1" (standard DIN 5480)		Option code "B1" (standard BS 3550)	
			k	l	k	l	k	l
MRD 700 F	101 [3.98]	78 [3.07]	62 [2.44]	B8x52x60	62 [2.44]	W60x3x18-8e	62 [2.44]	8/16-17
MRDE 800 F								
MRV 700 F								
MRVE 800 F								
MRD 1100 G	117 [4.61]	88 [3.46]	69 [2.72]	B8x62x72	67 [2.64]	W70x3x22-8e	72 [2.83]	6/12-14
MRDE 1100 G								
MRV 1100 G								
MRVE 1400 G								
MRD 1800 H	132 [5.20]	100 [3.94]	79 [3.11]	B10x72x82	76 [2.99]	W80x3x25-8e	80 [3.15]	6/12-20
MRDE 2100 H								
MRV 1800 H								
MRVE 2100 H								
MRD 2800 I	153 [6.02]	120 [4.72]	99 [3.90]	B10x82x92	76 [2.99]	W90x4x21-8e	100 [3.94]	6/12-20
MRDE 3100 I								
MRV 2800 I								
MRVE 3100 I								
MRD 4500 L	210 [8.27]	173 [6.81]	144 [5.67]	B10x102x112	142.5 [5.61]	W110x4x26-8	144 [5.67]	6/12-20
MRDE 5400 L								
MRV 4500 L								
MRVE 5400 L								
MRD 7000 M	230 [9.06]	188 [7.40]	150 [5.91]	B10x112x125	153 [6.02]	W120x4x28-8e	153 [6.02]	6/12-26

Measures in millimeters [inches in brackets]

Female and keyed shafts

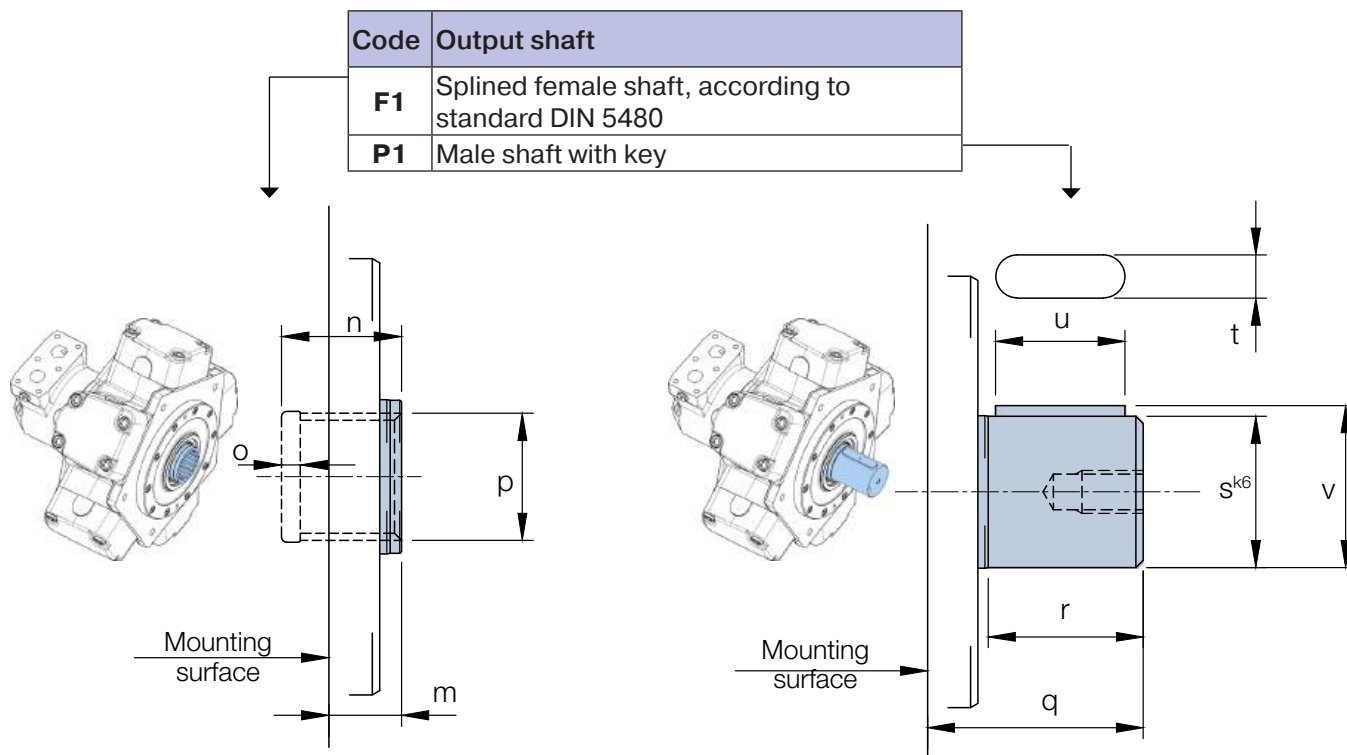

MOTOR TYPE	Female shafts - Option code "F1" (standard DIN 5480)				Keyed shafts - Option code "P1"														
	m	n	o	p	q	r	s ^{k6}	t	u	v									
MRD 300 D	27	41	5.2	N40x2x18-9H	81	60	50	14	56	53.5									
MRDE 330 D	[1.06]	[1.61]	[0.20]		[3.19]	[2.36]	[1.97]	[0.55]	[2.20]	[2.11]									
MRD 450 E	28	43	5.2	N47x2x22-9H	97	74	55	16	70	59									
MRDE 500 E											[1.10]	[1.69]	[0.20]	[3.82]	[2.91]	[2.17]	[0.63]	[2.76]	[2.32]
MRV 450 E																			

Measures in millimeters [inches in brackets]

MOTOR TYPE	Female shafts - Option code "F1" (standard DIN 5480)				Keyed shafts - Option code "P1"					
	m	n	o	p	q	r	s ^{k6}	t	u	v
MRD 700 F	28 [1.10]	49 [1.93]	5.2 [0.20]	N55x3x17-9H	101 [3.98]	78 [3.07]	60 [2.36]	18 [0.71]	70 [2.76]	64 [2.52]
MRDE 800 F										
MRV 700 F										
MRVE 800 F										
MRD 1100 G	38 [1.50]	58 [2.28]	8 [0.31]	N65x3x20-9H	117 [4.61]	88 [3.46]	70 [2.76]	20 [0.79]	80 [3.15]	74.5 [2.93]
MRDE 1100 G										
MRV 1100 G										
MRVE 1400 G										
MRD 1800 H	47 [1.85]	65 [2.56]	8 [0.31]	N75x3x24-9H	132 [5.20]	100 [3.94]	80 [3.15]	22 [0.87]	90 [3.54]	85 [3.35]
MRDE 2100 H										
MRV 1800 H										
MRVE 2100 H										
MRD 2800 I	48 [1.89]	70 [2.76]	8 [0.31]	N85x3x27-9H	153 [6.02]	120 [4.72]	90 [3.54]	25 [0.98]	110 [4.33]	95 [3.74]
MRDE 3100 I										
MRV 2800 I										
MRVE 3100 I										
MRD 4500 L	50 [1.97]	82 [3.23]	14 [0.55]	N100x3x32-9H	210 [8.27]	173 [6.81]	110 [4.33]	28 [1.10]	160 [6.30]	116 [4.57]
MRDE 5400 L										
MRV 4500 L										
MRVE 5400 L										
MRD 7000 M	50 [1.97]	90 [3.54]	14 [0.55]	N110x3x35-9H	230 [9.06]	188 [7.40]	124 ⁽²⁾ [4.88] ₍₂₎	32 [1.26]	180 [7.09]	138 ⁽¹⁾ [5.43] ₍₁₎

(1) = Two keys at 180°. For frame size M, the dimension "v" refers to the distance between the two keys.

(2) Tolerance for this frame size is b8

Measures in millimeters [inches in brackets]

Female and keyed shafts

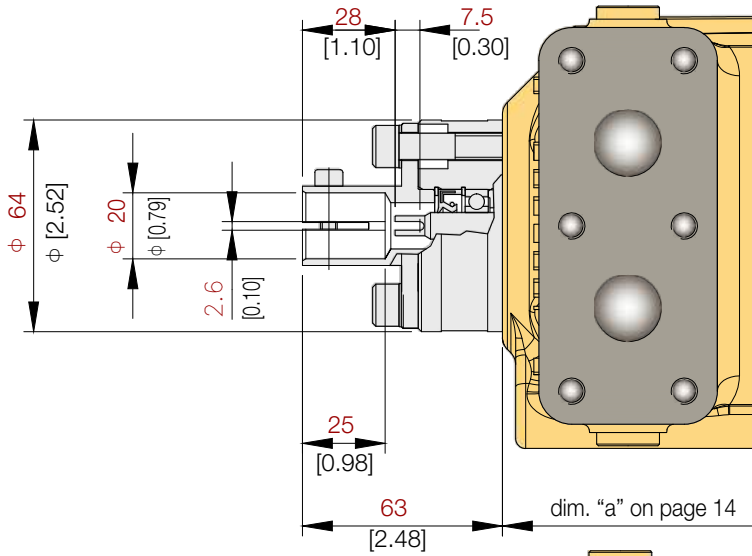

Speed sensor code	
C1	Connection for mechanical tachometer

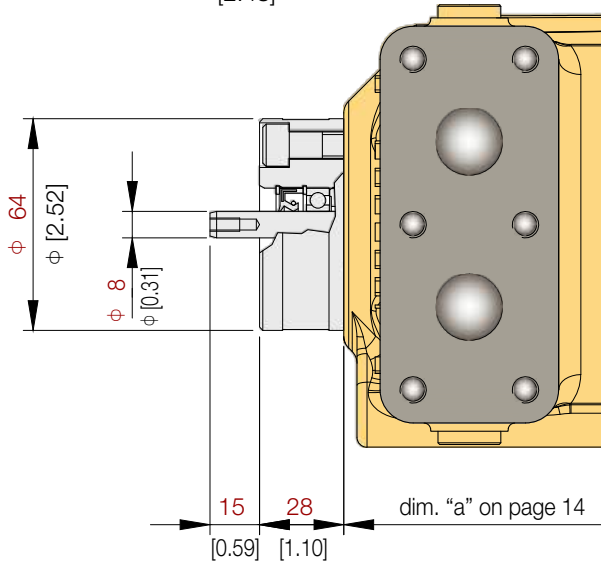

Speed sensor code	
Q1	Connection for encoder drive

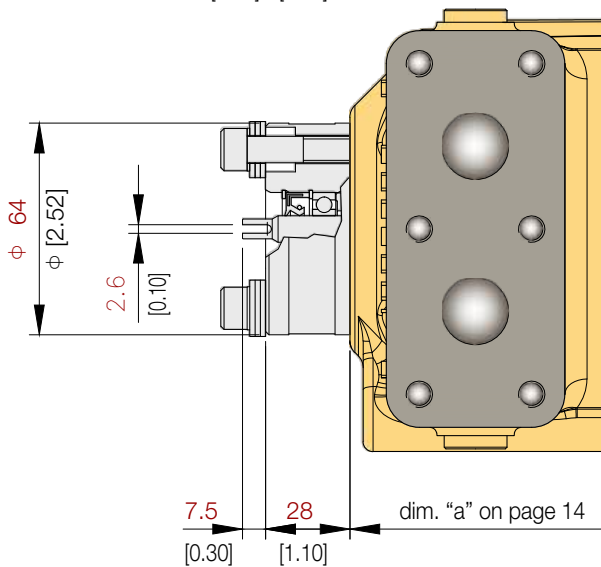

Speed sensor code	
T1	Connection for tachogenerator drive

Measures in millimeters [inches in brackets]

Incremental encoders

Code	Speed sensor
B1	Bidirectional incremental encode
M1	Monodirectional incremental encoder

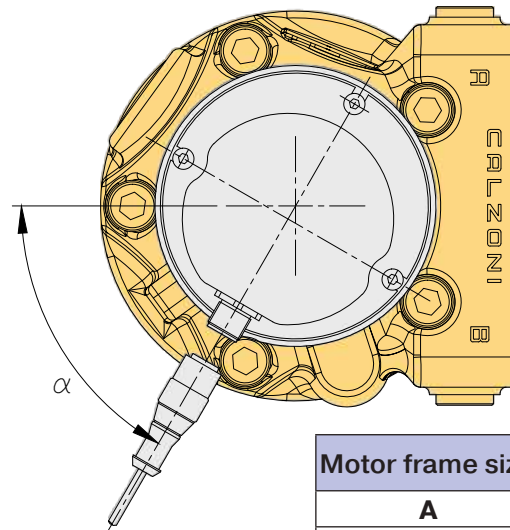
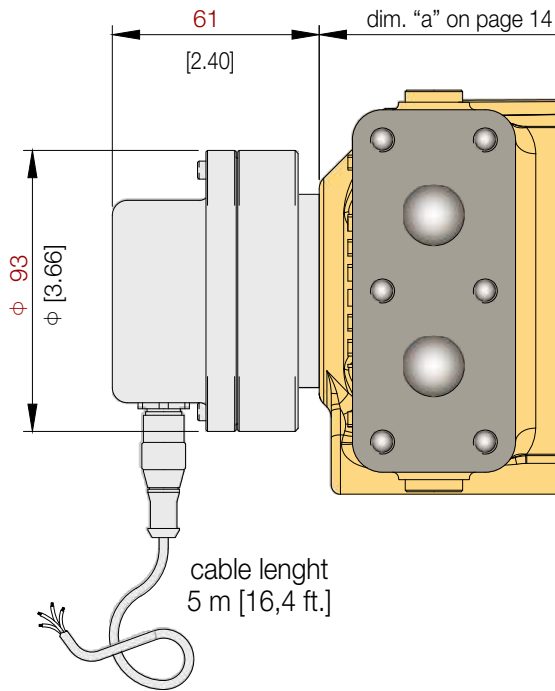

Motor frame size	α
A	126°
B, C, D, E, F	60°
G, H, I, L, M	45°

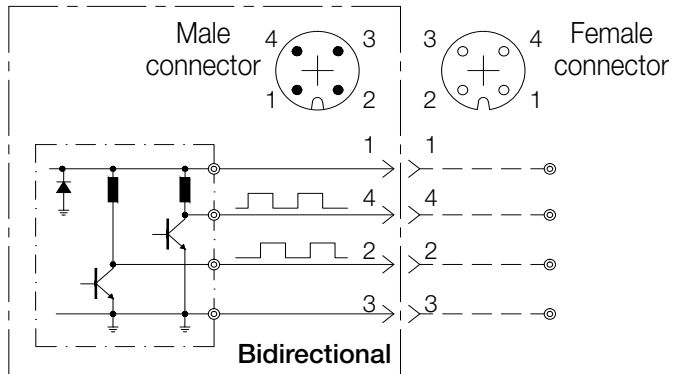
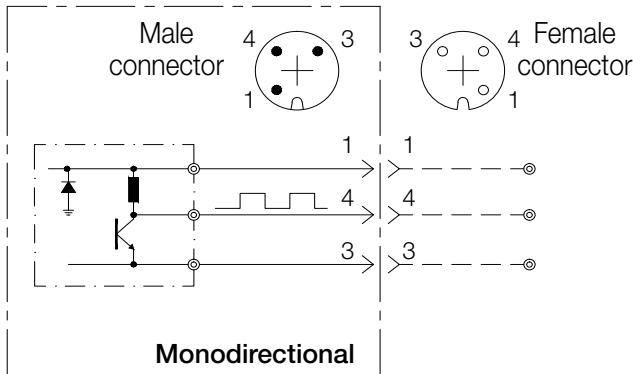

Color wires and function		
1	Brown	Power Supply
2	White	Output B phase
3	Blue	Ground
4	Black	Output A phase

Encoder type	Incremental (absolute on request)
Supply voltage	8 to 24 VDC
Current output	10 mA max
Output signal	A phase (MONODIRECTIONAL) A and B phase (BIDIRECTIONAL)
Number of pulses	500 (other on request)
Operating temperature	from 0°C to 70°C (from 32°F to 158 °F)
Protection degree	IP 67 (with protection and connection assembled)

Measures in millimeters [inches in brackets]

Six-bolt connections

Code	Fluid connections
N1	Six-bolt connection (for manifold)

N.B.: the six-bolt connection can be used to easily assemble a manifold on the motor. Use the six threaded holes to fix the manifold on the motor.

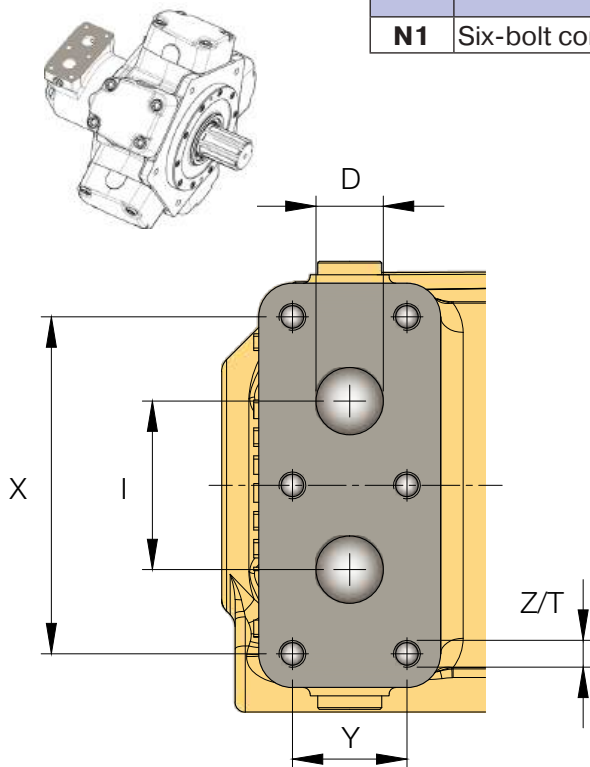

N.B.: Z/T = diameter/depth

MOTOR TYPE	Six-bolt connection - Option code "N1"				
	X	Y	I	D	Z/T
MRD 300 D	100	34	50	20	M8 / 15
MRDE 330 D	[3.94]	[1.34]	[1.97]	[0.79]	
MRD 450 E	120	40	61	25	M10 / 18
MRDE 500 E					
MRV 450 E					

MOTOR TYPE	Six-bolt connection - Option code "N1"				
	X	Y	I	D	Z/T
MRD 700 F	120	40	61	25	M10 / 18
MRDE 800 F					
MRV 700 F					
MRVE 800 F	136	50	73	31	M12 / 21
MRD 1100 G					
MRDE 1100 G					
MRV 1100 G					
MRVE 1400 G					
MRD 1800 H					
MRDE 2100 H					
MRV 1800 H					
MRVE 2100 H					
MRD 2800 I					
MRDE 3100 I					
MRV 2800 I					
MRVE 3100 I	200	68	116	38	M16 / 28
MRD 4500 L					
MRDE 5400 L					
MRV 4500 L					
MRVE 5400 L					
MRD 7000 M					

Measures in millimeters [inches in brackets]

SAE standard pressure adaptors

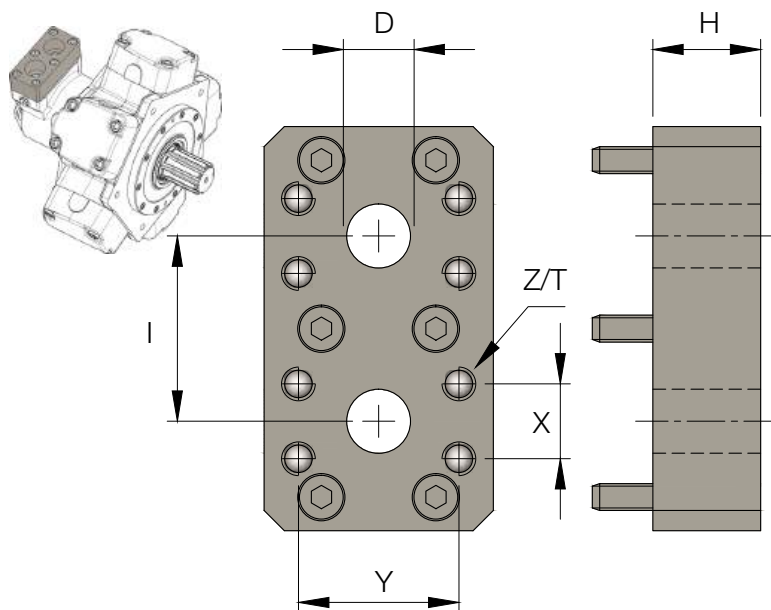

Code	Fluid connections
S1	Standard pressure SAE metric
T1	Standard pressure SAE UNC

N.B.: the flange is supplied complete with screws and seals, already assembled on the standard motor six-bolts connection (code N1).

N.B.: Z/T = diameter/depth

MOTOR TYPE	SAE PSI	H	D	I	X	Y	Standard pressure	
							Option code "S1" (SAE metric)	Option code "T1" (SAE UNC)
MRD 300 D	5000	38	19	55	22.2	47.6	M10 / 25	3/8-16UNC-2B / 0.98
MRDE 330 D		[1.50]	[3/4"]	[2.16]	[0.87]	[1.87]		
MRD 450 E	5000	39	25	62	26.2	52.4	M10 / 25	3/8-16UNC-2B / 0.98
MRDE 500 E		[1.53]	[1"]	[2.44]	[1.03]	[2.06]		
MRV 450 E								

Measures in millimeters [inches in brackets]

MOTOR TYPE	SAE PSI	H	D	I	X	Y	Standard pressure	
							Option code "S1" (SAE metric)	Option code "T1" (SAE UNC)
MRD 700 F	5000	39 [1.53]	25 [1"]	62 [2.44]	26.2 [1.03]	52.4 [2.06]	M10 / 25	3/8-16UNC-2B / 0.98
MRDE 800 F								
MRV 700 F								
MRVE 800 F								
MRD 1100 G	4000	45 [1.77]	31 [1-1/4"]	75 [2.95]	30.2 [1.19]	58.7 [2.31]	M10 / 25	7/16-14UNC-2B / 1.18
MRDE 1100 G								
MRV 1100 G								
MRVE 1400 G								
MRD 1800 H								
MRDE 2100 H								
MRV 1800 H								
MRVE 2100 H								
MRD 2800 I	3000	59 [2.32]	37 [1-1/2"]	86 [3.39]	35.7 [1.40]	69.8 [2.75]	M12 / 30	1/2-13UNC-2B / 1.18
MRDE 3100 I								
MRV 2800 I								
MRVE 3100 I								
MRD 4500 L	3000	58 [2.28]	50 [2"]	112 [4.41]	42.9 [1.69]	77.8 [3.06]	M12 / 30	1/2-13UNC-2B / 1.18
MRDE 5400 L								
MRV 4500 L								
MRVE 5400 L								
MRD 7000 M								

SAE high pressure adaptors

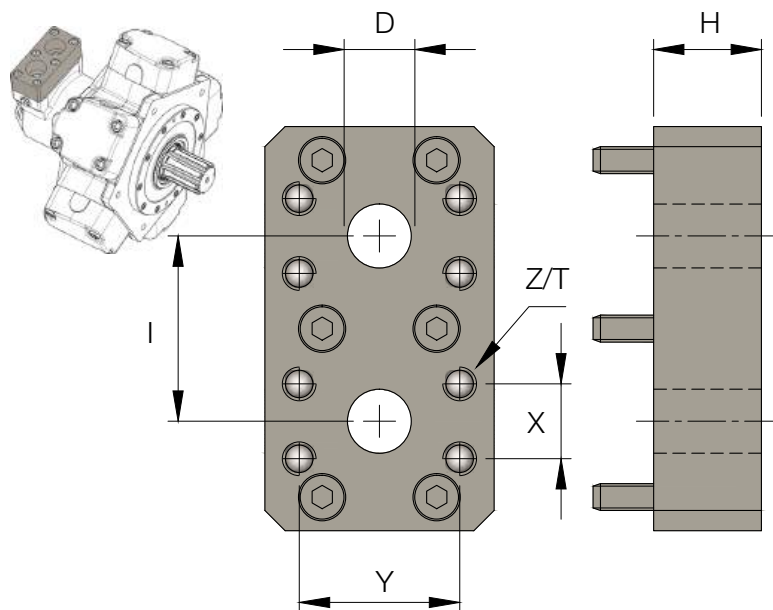

Code	Fluid connections
G1	High pressure SAE metric (6000 psi)
L1	High pressure SAE UNC (6000 psi)

N.B.: the flange is supplied complete with screws and seals, already assembled on the standard motor six-bolts connection (code N1).

N.B.: Z/T = diameter/depth

MOTOR TYPE	SAE PSI	H	D	I	X	Y	Standard pressure	
							Option code "G1" (SAE metric)	Option code "L1" (SAE UNC)
MRD 1100 G	6000	45 [1.77]	25 [1"]	71 [2.79]	27.8 [1.09]	57.15 [2.25]	M12 / 30	7/16-14UNC-2B / 1.18
MRDE 1100 G								
MRV 1100 G								
MRVE 1400 G								
MRD 1800 H								
MRDE 2100 H								
MRV 1800 H								
MRVE 2100 H								
MRD 2800 I	6000	59 [2.32]	37 [1-1/2"]	100 [3.94]	36.5 [1.44]	79.4 [3.13]	M16 / 30	5/8-11UNC-2B / 1.38
MRDE 3100 I								
MRV 2800 I								
MRVE 3100 I								
MRD 4500 L	6000	58 [2.28]	50 [2"]	116 [4.57]	44.45 [1.75]	96.8 [3.81]	M20 / 35	3/4-10UNC-2B / 1.50
MRDE 5400 L								
MRV 4500 I								
MRVE 5400 L								
MRD 7000 M								

Measures in millimeters [inches in brackets]

BSP threads adaptors

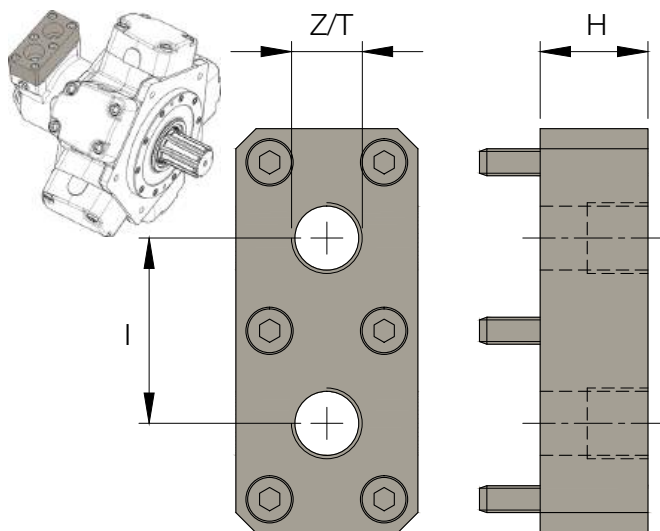

Code	Fluid connections
C1	BSP threads (according to ISO 228/1)

N.B.: the flange is supplied complete with screws and seals, already assembled on the standard motor six-bolts connection (code N1).

N.B.: Z/T = diameter/depth

BSP threads flange - Option code "C1"			
MOTOR TYPE	Z/T	H	I
MRD 300 D	G 3/4" / 18	38	50
MRDE 330 D		[1.50]	[1.97]
MRD 450 E	G 1 1/4" / 22	39	60
MRDE 500 E		[1.53]	[2.36]
MRV 450 E			

BSP threads flange - Option code "C1"			
MOTOR TYPE	Z/T	H	I
MRD 700 F	G 1 1/4" / 22	39	60
MRDE 800 F		[1.53]	[2.36]
MRV 700 F			
MRVE 800 F	G 1 1/2" / 25	45	71
MRD 1100 G		[1.77]	[2.79]
MRDE 1100 G			
MRV 1100 G			
MRVE 1400 G			
MRD 1800 H			
MRDE 2100 H	G 1 1/2" / 25	59	86
MRV 1800 H		[2.32]	[3.39]
MRVE 2100 H			
MRD 2800 I	G 2" / 28	58	112
MRDE 3100 I		[2.28]	[4.41]
MRV 2800 I			
MRVE 3100 I			
MRD 4500 L			
MRDE 5400 L			
MRV 4500 L			
MRVE 5400 I			
MRD 7000 M			

Measures in millimeters [inches in brackets]

Parking brake

The parking brake is a “spring applied - hydraulic pressure release” multi-disc brake, that has been designed for those applications where it is necessary to hold the system under an external torque without pressure feeding (the brake can be used in dynamic conditions only in case of emergency).

Hydraulic pressure is required to “hold off” the brake. During normal operation the brake is pressurized in the released position, while the maximum braking torque is achieved when the brake is not fed. Any function which reduces the hydraulic system below the release pressure of the brake will cause the brake to be activate.

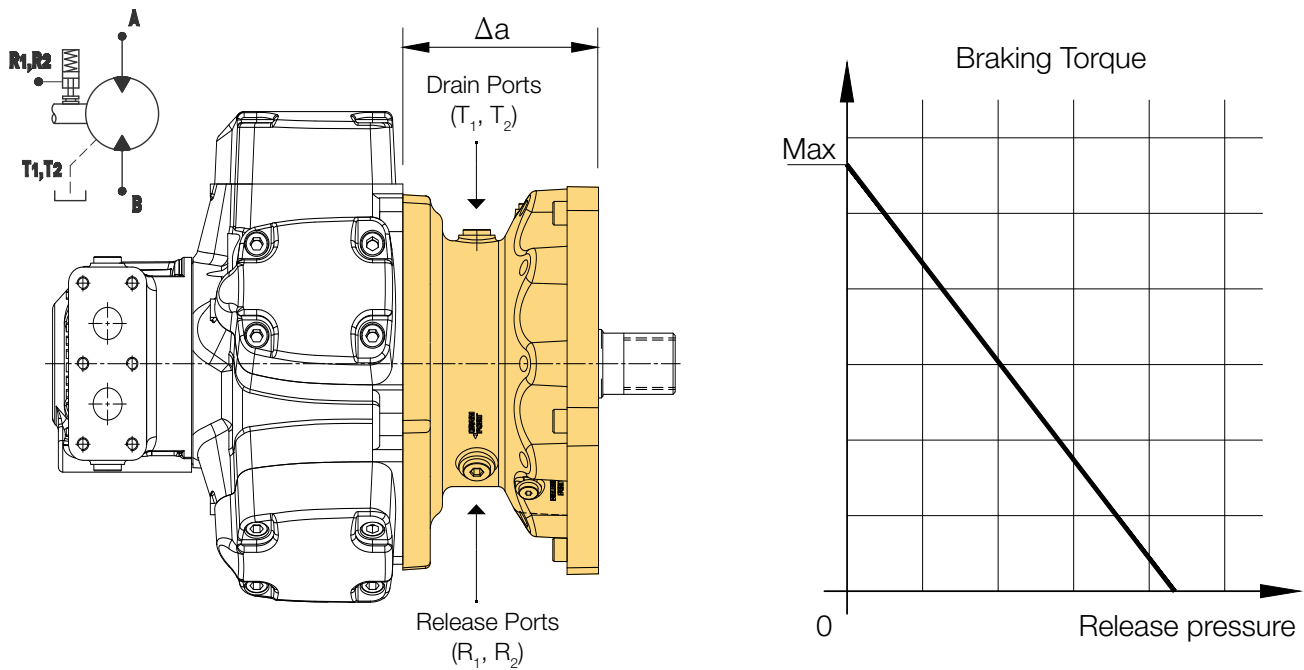

The release pressure represents the pressure value to completely release the brake (no braking torque). In case of hydraulic motor equipped with parking brake, the brake length (D_a) and the brake mass (D_m) have to be added to the correspondig motor values (without brake) to calculate the total lenght and mass.

MOTOR TYPE	Δa	Δm	Static Braking Torque ($\mu=0.14$)		Dynamic Braking Torque ($\mu=0.09$)		Release Pressure				
			Max	Min	Max	Min					
MRD 300 D	135 mm 5.3 in	29 kg 64 lb	2150 N.m	1800 N.m	1450 N.m	1450 N.m	28 bar 406 psi				
MRDE 330 D			1585 lbf.ft	1330 lbf.ft	1070 lbf.ft	1070 lbf.ft					
MRD 450 E	172 mm 18.6 in	45 kg 99 lb	3400 N.m	3100 N.m	2300 N.m	2100 N.m	30 bar 435 psi				
MRDE 500 E			2510 lbf.ft	2285 lbf.ft	1695 lbf.ft	1550 lbf.ft					
MRV 450 E		60 kg 132 lb	4800 N.m	4100 N.m	3200 N.m	2800 N.m					
MRD 700 F								3540 lbf.ft	3025 lbf.ft	2360 lbf.ft	2065 lbf.ft
MRDE 800 F											
MRV 700 F											
MRVE 800 F											
MRD 1100 G											
MRDE 1100 G	5530 lbf.ft	4500 lbf.ft	3690 lbf.ft	3020 lbf.ft							
MRV 1100 G											
MRVE 1400 G											
MRD 1800 H					211 mm 8.3 in	176 kg 388 lb	13200 N.m	10390 N.m	8500 N.m	7000 N.m	27 bar 392 psi
MRDE 2100 H	9735 lbf.ft	8040 lbf.ft	6270 lbf.ft	5160 lbf.ft							
MRV 1800 H											
MRVE 2100 H											
MRD 2800 I					222 mm 8.74 in	225 kg 496 lb	20000 N.m	16200 N.m	12900 N.m	10400 N.m	30 bar 435 psi
MRDE 3100 I	14750 lbf.ft	11950 lbf.ft	9515 lbf.ft	7670 lbf.ft							
MRV 2800 I											
MRVE 3100 I											
MRD 4500 I					287 mm 11.3 in	460 kg 1014 lb	34300 N.m	28500 N.m	22100 N.m	18400 N.m	
MRDE 5400 L	25300 lbf.ft	21020 lbf.ft	16300 lbf.ft	13570 lbf.ft							
MRV 4500 L											
MRVE 5400 L											
MRD 7000 M					340 mm 13.4 in	652 kg 1437 lb	51400 N.m 37910 lbf.ft	40500 N.m 29870 lbf.ft	33200 N.m 24490 lbf.ft	26200 N.m 19325 lbf.ft	

Important notes:

- For correct braking operations, the hydraulic release pressure to the brake must fall to zero. Any residual release back pressure applied to the brake degrades braking torque and may result in hazardous conditions;
- Please contact Calzoni in case axial or radial loads are applied to the brake shaft;
- Refer to catalogue CH-B-504.0/EN for complete brakes list and options.

Mineral-oil based fluids

Performance data of this catalogue is valid when motors are operating with mineral oil based fluids, according to DIN 51525. The fluid should contain anti-oxidant, antifoam, demulsifying and antiwear or EP additives.

The viscosity, quality and cleanliness of operating fluids are decisive factors in determining the reliability, performance and life-time of an hydraulic component.

The maximum life-time and performance are achieved within the recommended viscosity range of 30 - 50 cSt. For applications that go beyond this range, we recommend to contact the manufacturer of the motor.

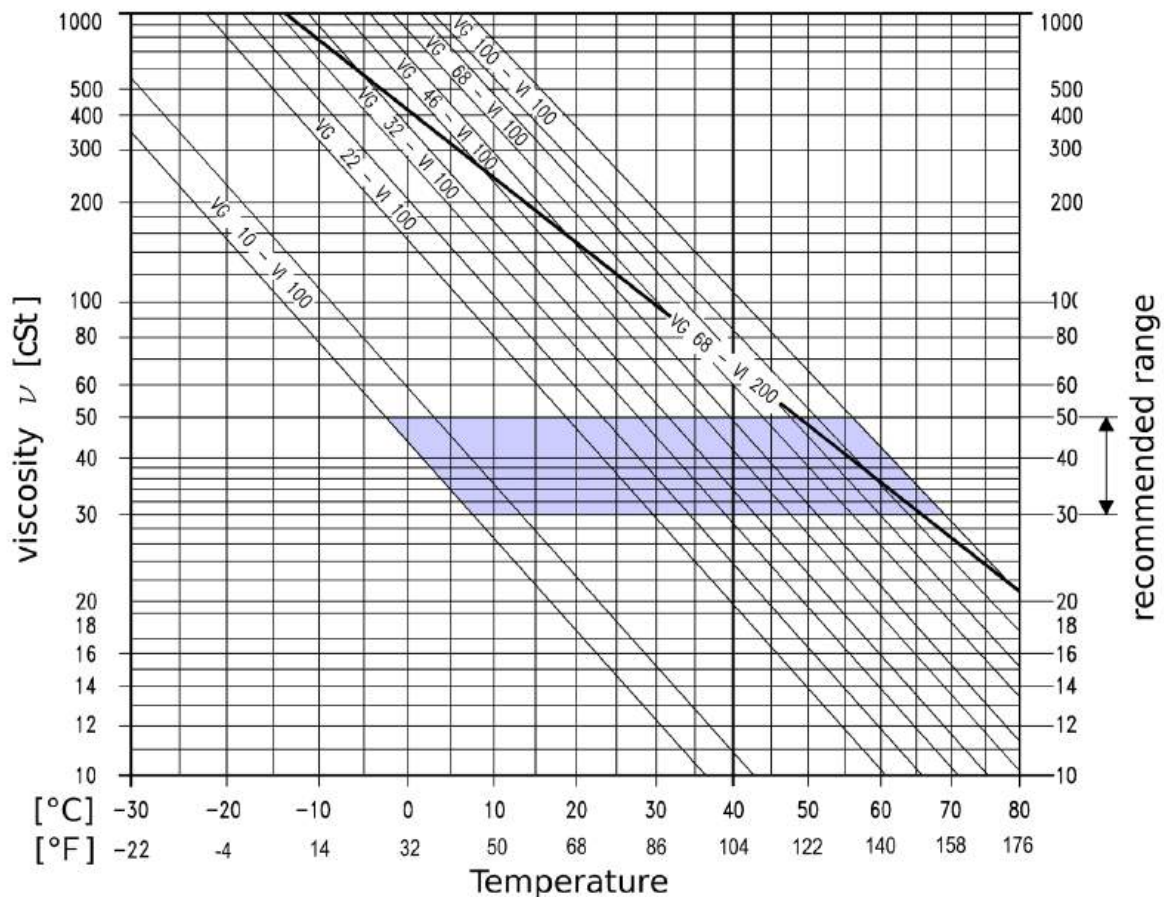

The viscosity refers both to the temperature of the fluid entering the motor and to the temperature inside the motor housing (case temperature). Based on the maximum operating temperature, we recommend to select the fluid so that its viscosity remains within the recommended viscosity range.

For critical operation conditions the following values apply:

- $V_{\min, \text{peak}}$ = 10 cSt in emergency, short term;
- $V_{\min, \text{cont.}}$ = 18 cSt for continuous operation at reduced performances;
- $V_{\max.}$ = 1000 cSt short term upon cold start.

The drain oil temperature is influenced by pressure and speed and is usually higher than the circuit temperature or the tank temperature. At no point in the motor, however, may the temperature be higher than 80°C (max admitted temperature).

In case of operating conditions with high oil temperature or high ambient temperature, we recommend to use “FPM” seals (option code “V1”). These “FPM” seals should be also used with HFD fluids.

If these viscosity requirements cannot be met, due to extreme operating parameters or high environment temperature, motor case flushing is strictly recommended in order to operate within the viscosity limits.

Should it be absolutely necessary to use a viscosity exceeding the recommended range, please contact Calzoni. Filtration improves the cleanliness level of the hydraulic fluid and increases the service life of the motor. To ensure the functional reliability of the motor, a cleanliness level of at least 20/18/15 to ISO 4406 (equivalent to level 9 according to NAS 1638 or 6 to SAE 749) is to be maintained in the circuit.

Other fluids

Calzoni radial piston motors can operate successfully on a wide variety of fluids. As a general guide de-rating factors are set out below:

Class	Description	Pressure	Speed	Power	Temperature	
					Max	Ideal
-	-	(% of nominal pressure)	(% of max speed)	(% of max power)		
HFA	Oil-water emulsion	50	50	25	50 °C 122 °F	40 °C 104 °F
HFB	Water-oil emulsion	80	80	60	60 °C 140 °F	45 °C 113 °F
HFC	Water-based solution (mostly with glycol)	60	60	30	60 °C 140 °F	45 °C 113 °F
HFD	Synthetic fluids (water free)	100	100	100	80 °C 176 °F	50 °C 122 °F

The use of synthetic fluids (type HFD) is allowed with motors supplied with seals in "FPM" material (pls. contact Calzoni about the use of motors with synthetic fluids). The use of synthetic fluids (type HFD) does not imply any motor performances reduction.

Please specify make and type of fluid on your order if other than petroleum oil.

Operating diagram

(average values) measured at $v = 36 \text{ mm}^2/\text{s}$; $t = 45^\circ\text{C}$; $p_{\text{outlet}} = 0 \text{ bar}$

- 1 Output power 2 Intermittent operating area
- 3 Continuous operating area with flushing
- 4 Continuous operating area
- 5 Inlet pressure η_t Total efficiency η_v Volumetric efficiency

MRD 300

set to
 304 cm³

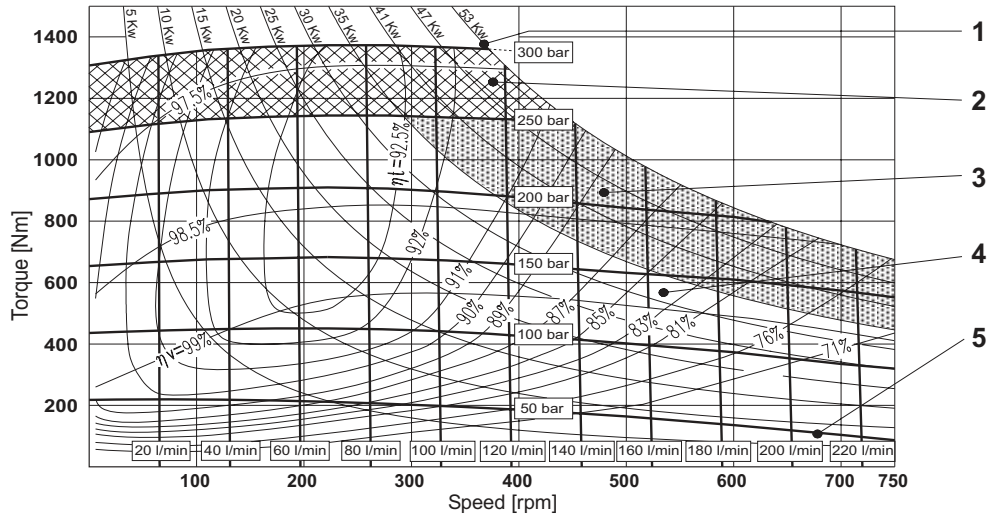

MRD 300

set to
 152 cm³

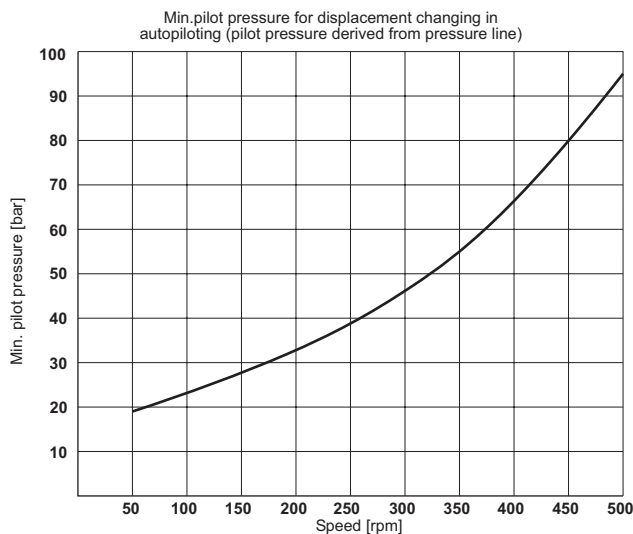
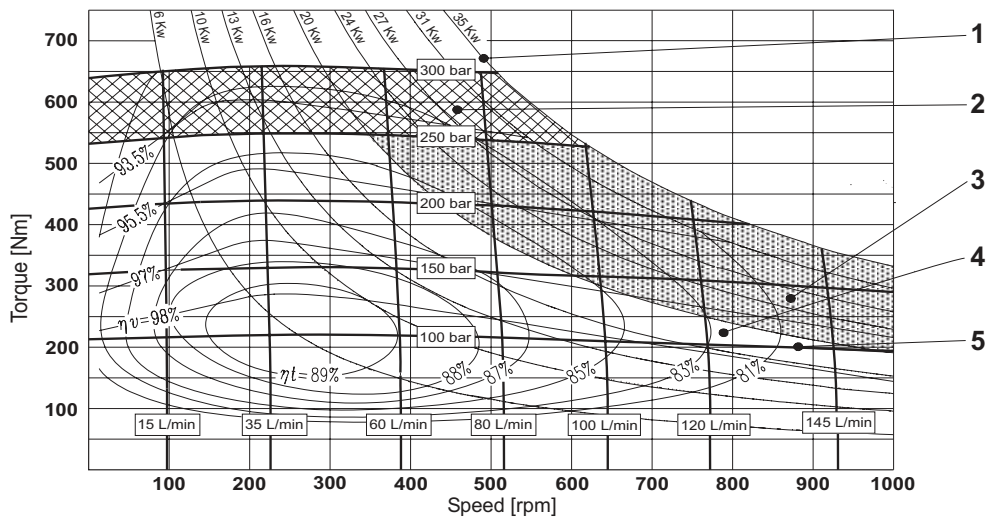

Valid for back pressure up to 50 bar, drain pressure up to 5 bar.
 For other working conditions please consult PARKER Calzoni

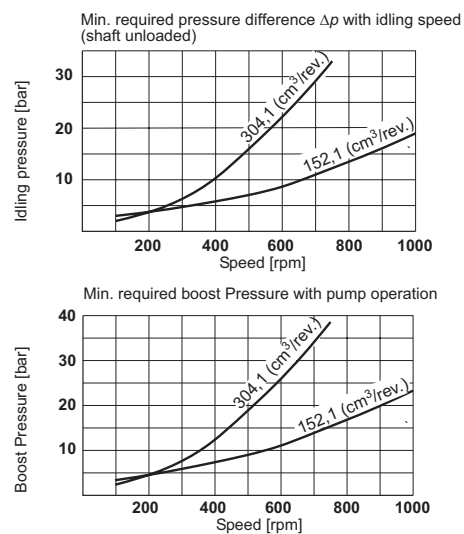

Operating diagram

(average values) measured at $v = 36 \text{ mm}^2/\text{s}$; $t = 45^\circ\text{C}$; $p_{\text{outlet}} = 0 \text{ bar}$

- 1** Output power **2** Intermittent operating area
- 4** Continuous operating area **5** Inlet pressure η_t Total efficiency η_v Volumetric efficiency

MRDE 330

set to
332 cm³

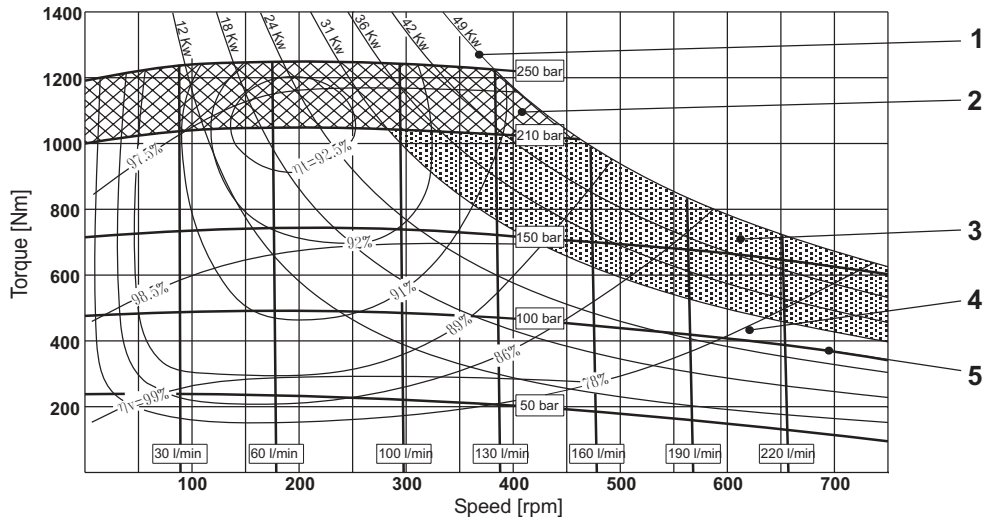

MRDE 300

set to
166 cm³

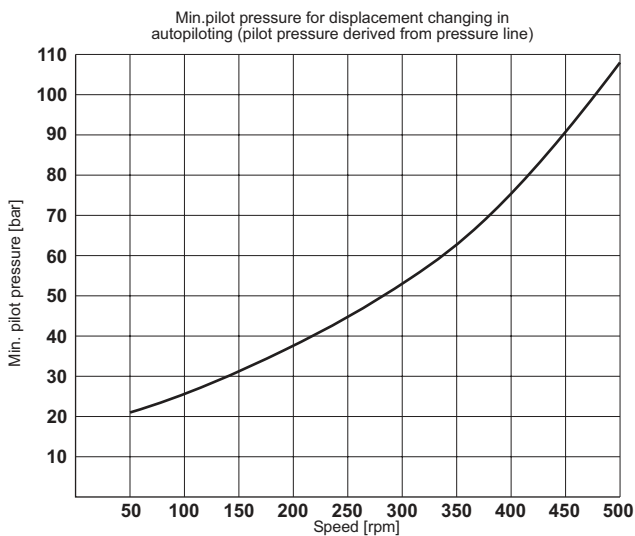
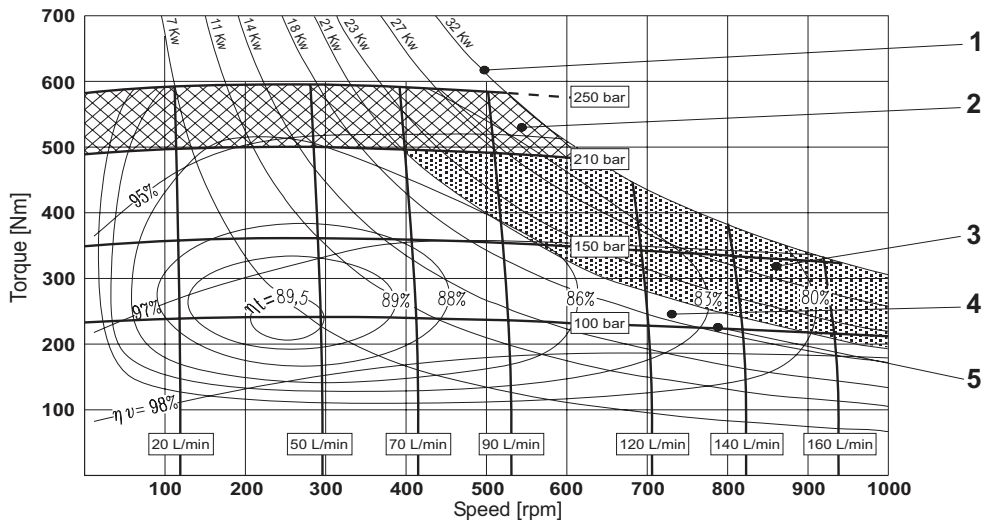

Valid for back pressure up to 50 bar, drain pressure up to 5 bar.
 For other working conditions please consult PARKER Calzoni

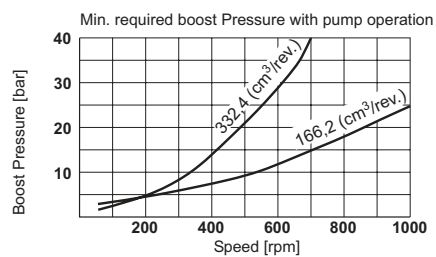
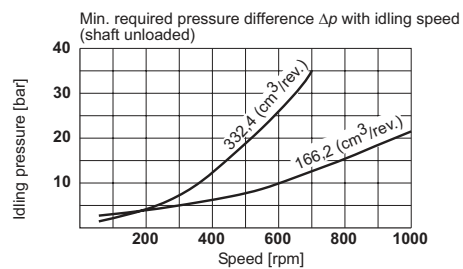

Operating diagram

(average values) measured at $v = 36 \text{ mm}^2/\text{s}$; $t = 45^\circ\text{C}$; $p_{\text{outlet}} = 0 \text{ bar}$

- 1** Output power **2** Intermittent operating area
- 4** Continuous operating area **5** Inlet pressure η_t Total efficiency η_v Volumetric efficiency

**MRD 450
 MRV 450**

set to
452 cm³

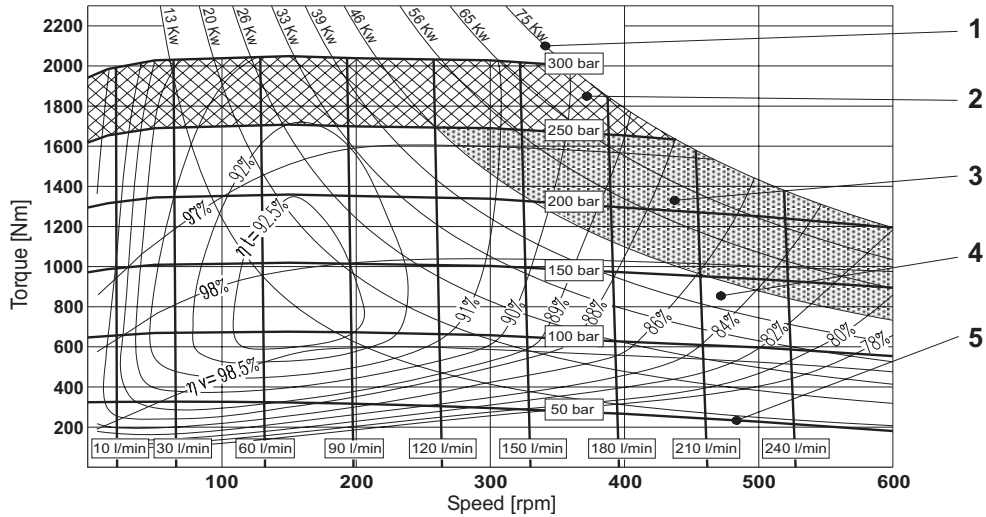

**MRD 450
 MRV 450**

set to
226 cm³

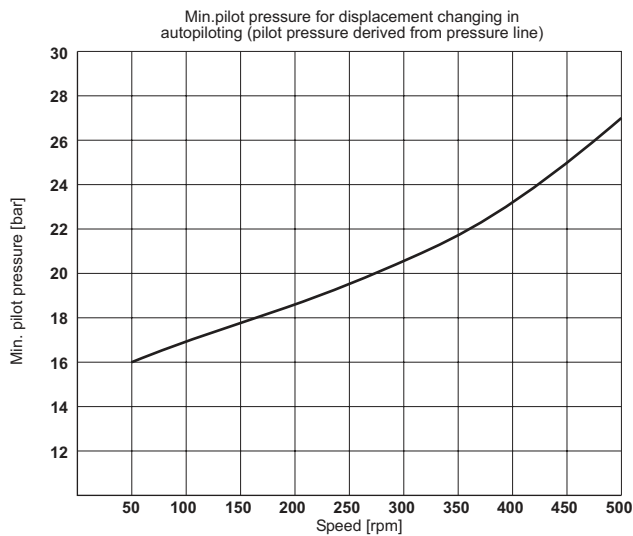
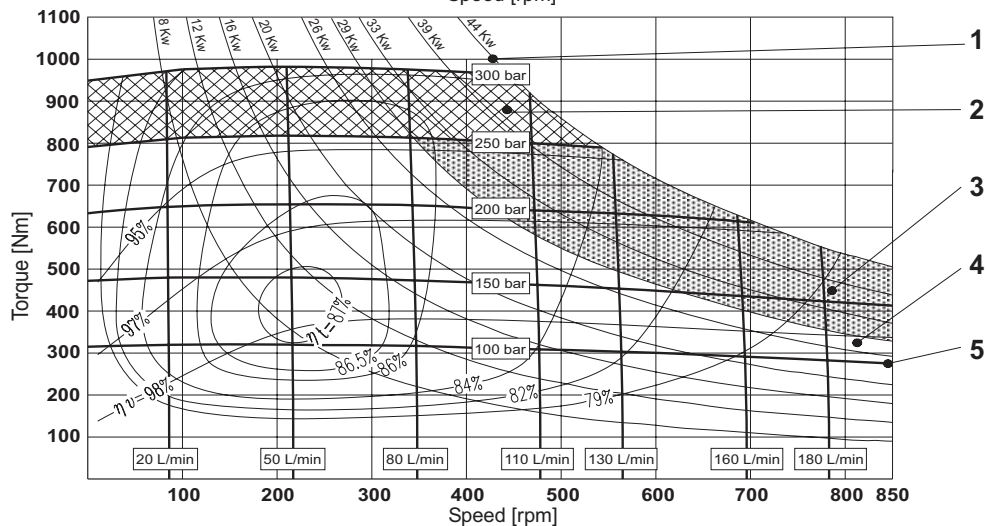

Valid for back pressure up to 50 bar, drain pressure up to 5 bar.
 For other working conditions please consult PARKER Calzoni

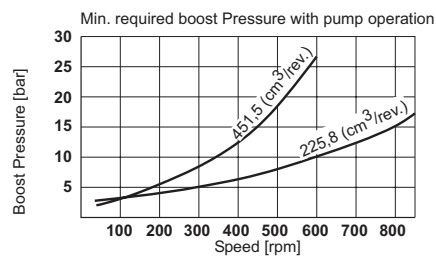
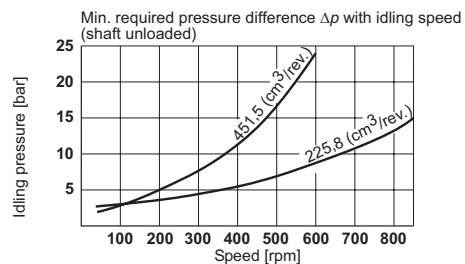

Operating diagram

(average values) measured at $v = 36 \text{ mm}^2/\text{s}$; $t = 45^\circ\text{C}$; $p_{\text{outlet}} = 0 \text{ bar}$

- 1** Output power **2** Intermittent operating area
- 3** Continuous operating area with flushing
- 4** Continuous operating area
- 5** Inlet pressure η_t Total efficiency η_v Volumetric efficiency

MRDE 500

set to
498 cm³

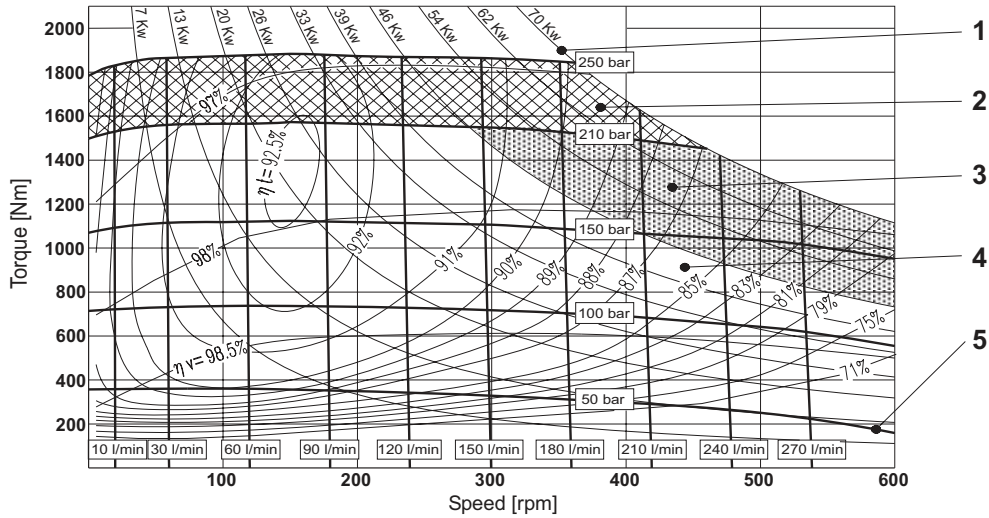

MRDE 500

set to
249 cm³

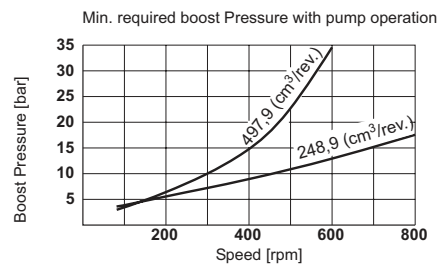
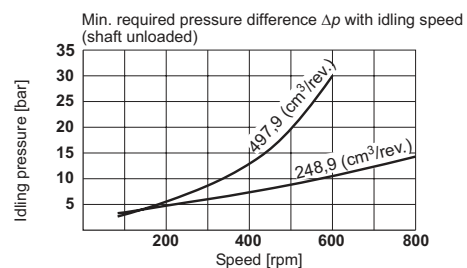
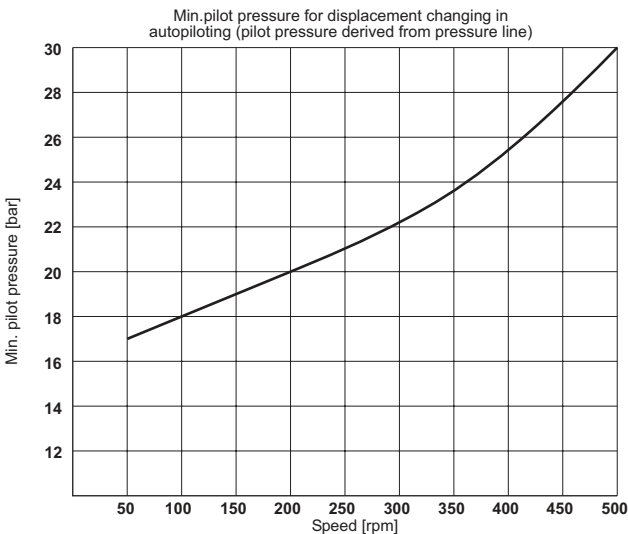
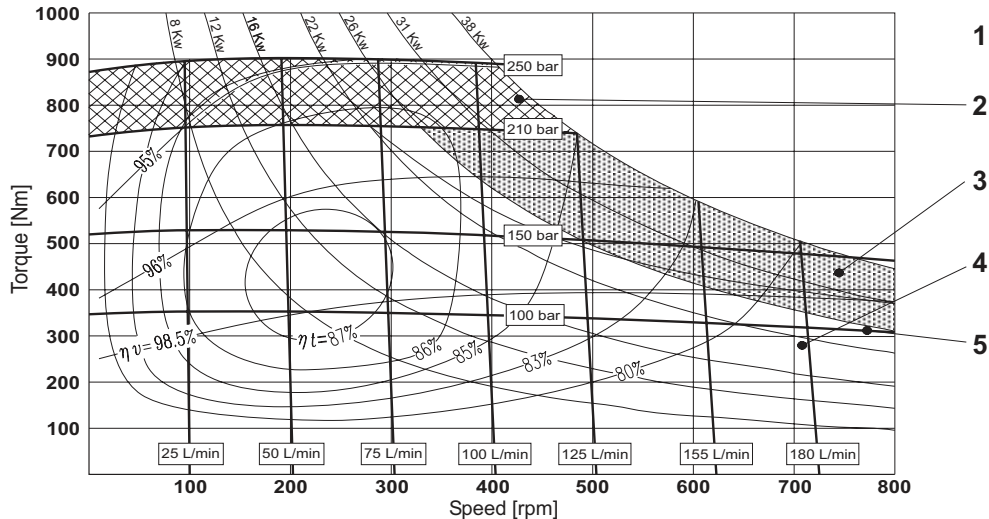

Valid for back pressure up to 50 bar, drain pressure up to 5 bar.
 For other working conditions please consult PARKER Calzoni

Operating diagram

(average values) measured at $v = 36 \text{ mm}^2/\text{s}$; $t = 45^\circ\text{C}$; $p_{\text{outlet}} = 0 \text{ bar}$

- 1** Output power **2** Intermittent operating area
- 4** Continuous operating area **5** Inlet pressure η_t Total efficiency η_v Volumetric efficiency

**MRD 700
 MRV 700**

set to
707 cm³

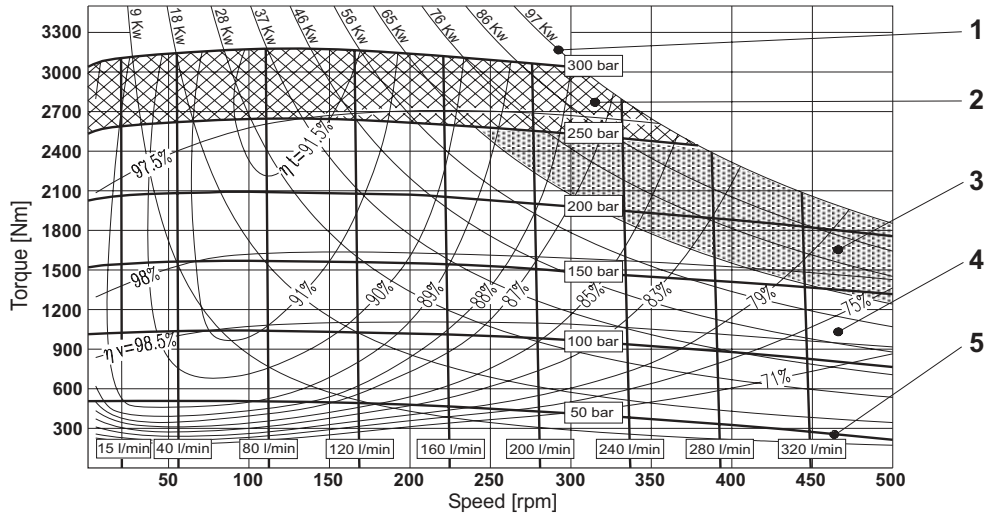

**MRD 700
 MRV 700**

set to
238 cm³

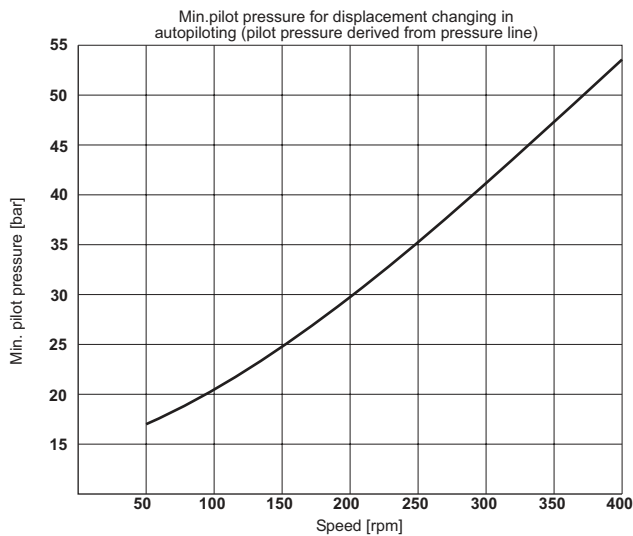
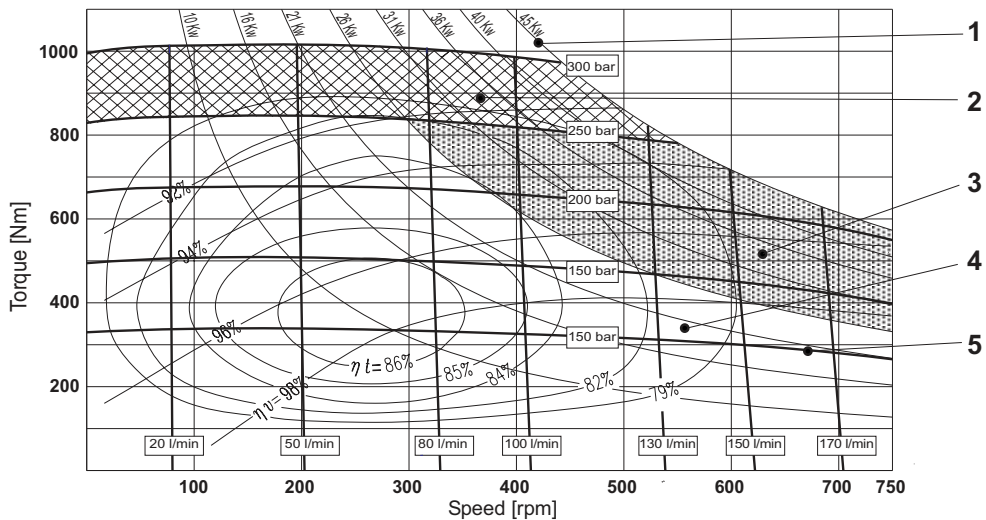

Valid for back pressure up to 50 bar, drain pressure up to 5 bar.
 For other working conditions please consult PARKER Calzoni

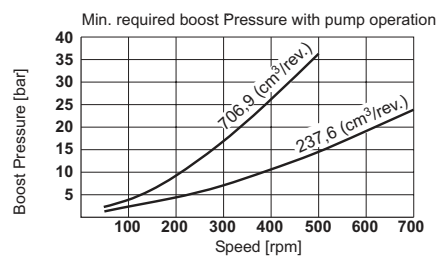
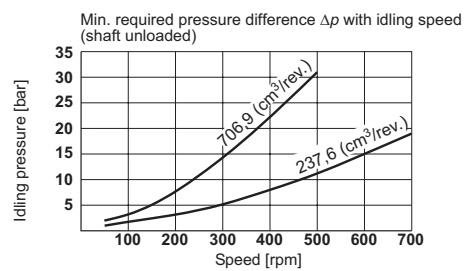

Operating diagram

(average values) measured at $v = 36 \text{ mm}^2/\text{s}$; $t = 45^\circ\text{C}$; $p_{\text{outlet}} = 0 \text{ bar}$

- 1** Output power **2** Intermittent operating area
- 3** Continuous operating area with flushing
- 4** Continuous operating area
- 5** Inlet pressure η_t Total efficiency η_v Volumetric efficiency

**MRDE 800
 MRVE 800**

set to
804 cm³

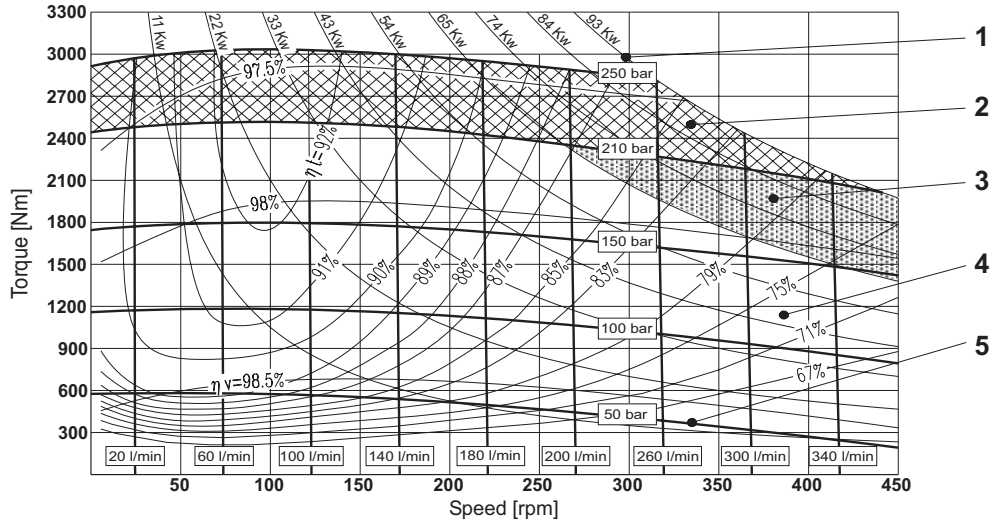

**MRDE 800
 MRVE 800**

set to
270 cm³

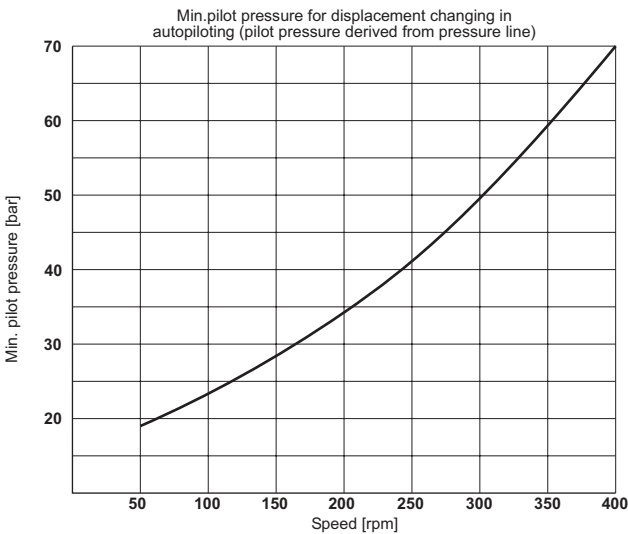
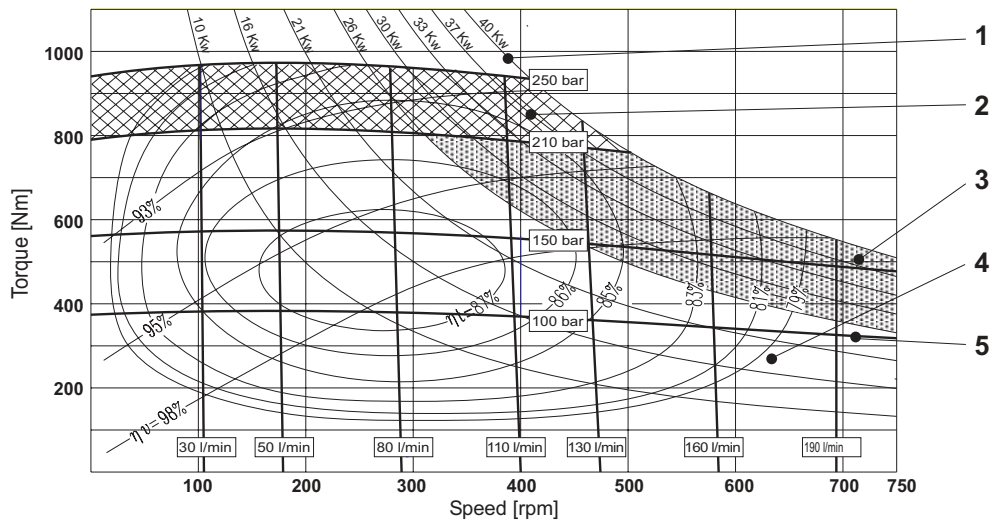

Valid for back pressure up to 50 bar, drain pressure up to 5 bar.
 For other working conditions please consult PARKER Calzoni

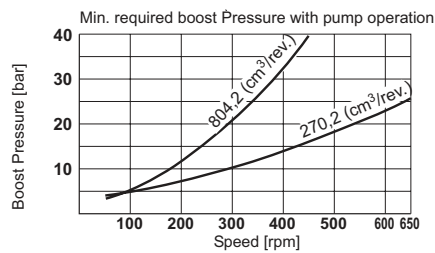
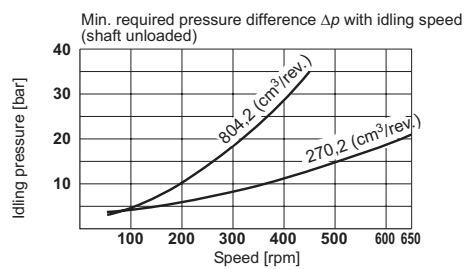

Operating diagram

(average values) measured at $v = 36 \text{ mm}^2/\text{s}$; $t = 45^\circ\text{C}$; $p_{\text{outlet}} = 0 \text{ bar}$

- 1** Output power **2** Intermittent operating area
- 4** Continuous operating area **5** Inlet pressure η_t Total efficiency η_v Volumetric efficiency

**MRD 1100
 MRV 1100**

set to
1126 cm³

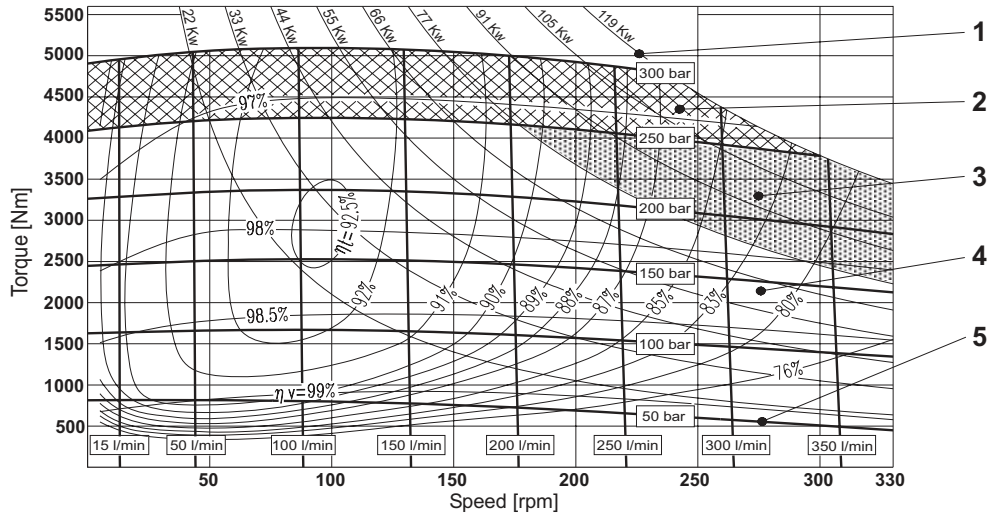

**MRD 1100
 MRV 1100**

set to
381 cm³

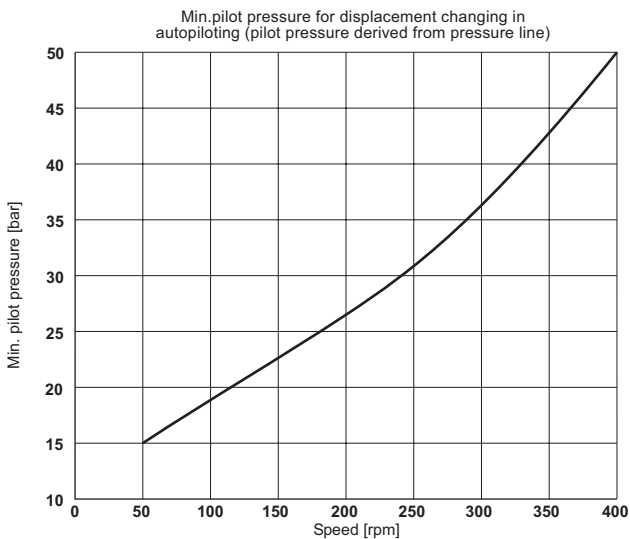
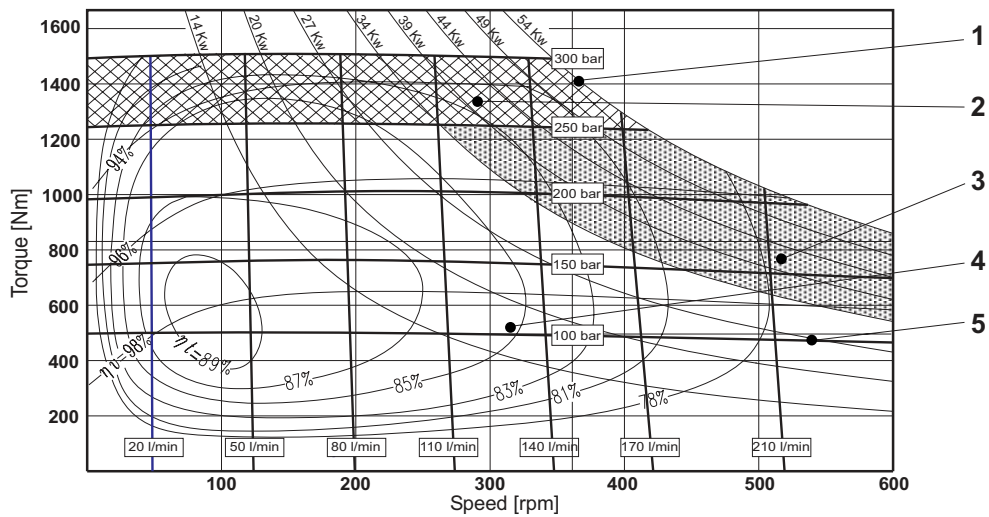

Valid for back pressure up to 50 bar, drain pressure up to 5 bar.
 For other working conditions please consult PARKER Calzoni

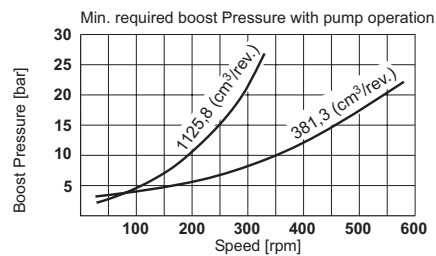
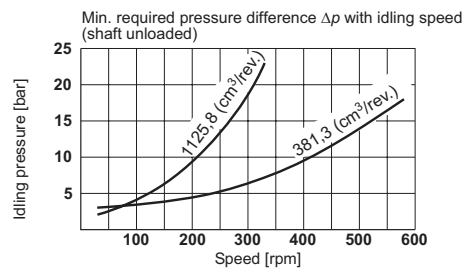

Operating diagram

(average values) measured at $v = 36 \text{ mm}^2/\text{s}$; $t = 45^\circ\text{C}$; $p_{\text{outlet}} = 0 \text{ bar}$

- 1** Output power **2** Intermittent operating area
- 3** Continuous operating area with flushing
- 4** Continuous operating area
- 5** Inlet pressure η_t Total efficiency η_v Volumetric efficiency

MRDE 1400
MRVE 1400

set to
1370 cm³

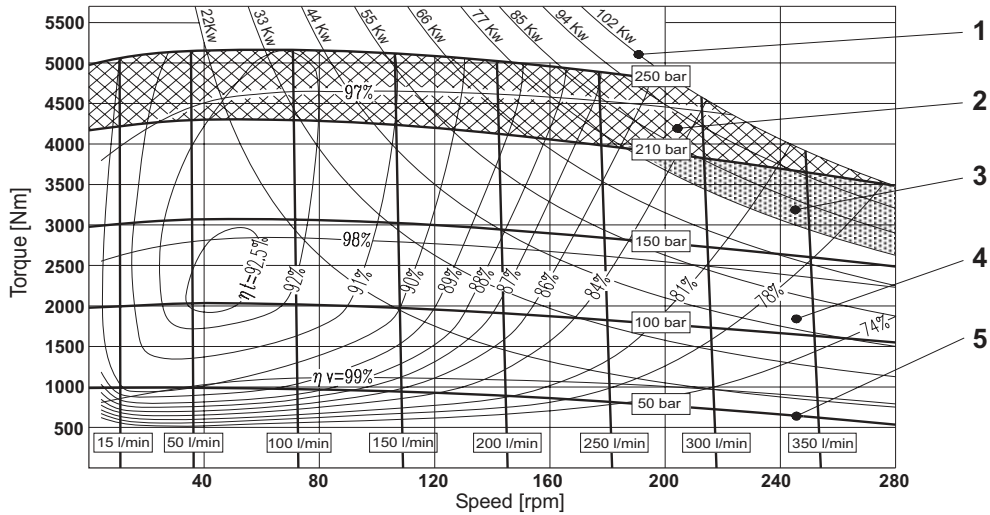

MRDE 1400
MRVE 1400

set to
464 cm³

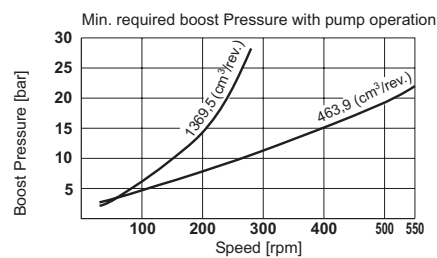
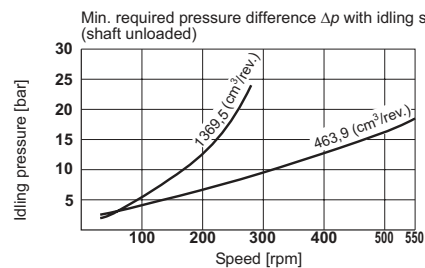
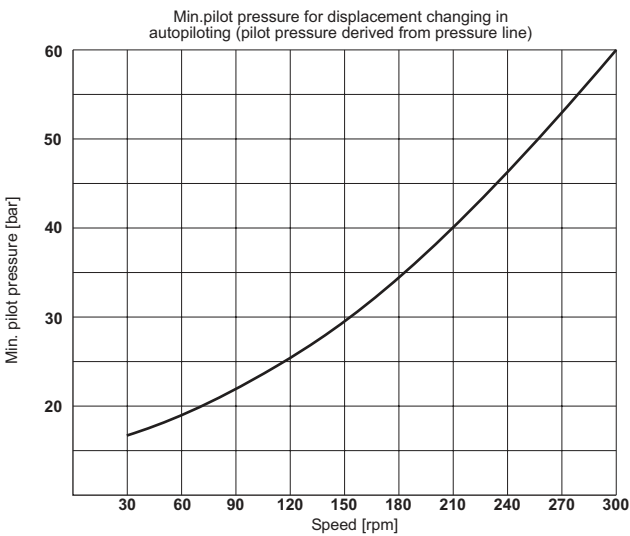
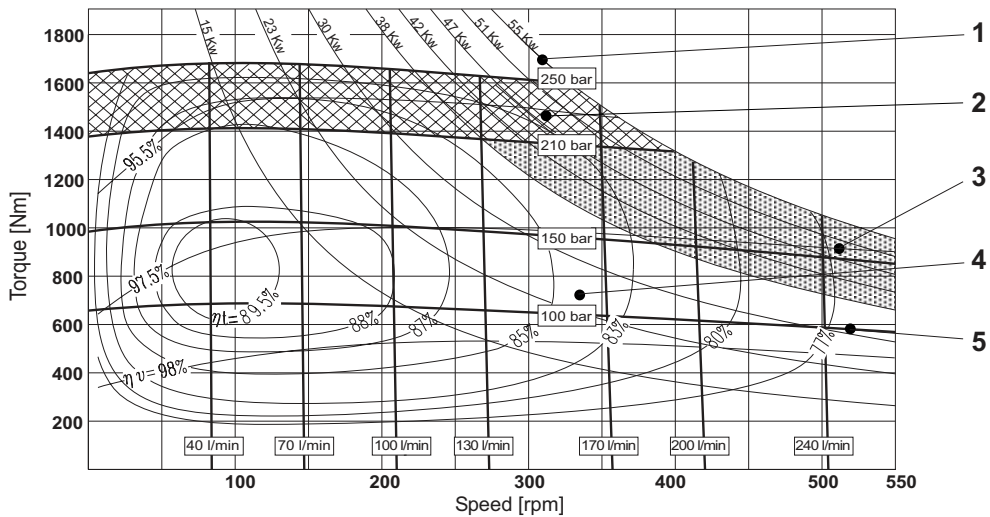

Valid for back pressure up to 50 bar, drain pressure up to 5 bar.
 For other working conditions please consult PARKER Calzoni

Operating diagram

(average values) measured at $v = 36 \text{ mm}^2/\text{s}$; $t = 45^\circ\text{C}$; $p_{\text{outlet}} = 0 \text{ bar}$

- 1 Output power 2 Intermittent operating area
- 3 Continuous operating area with flushing
- 4 Continuous operating area
- 5 Inlet pressure η_t Total efficiency η_v Volumetric efficiency

**MRD 1800
 MRV 1800**

set to
1810 cm³

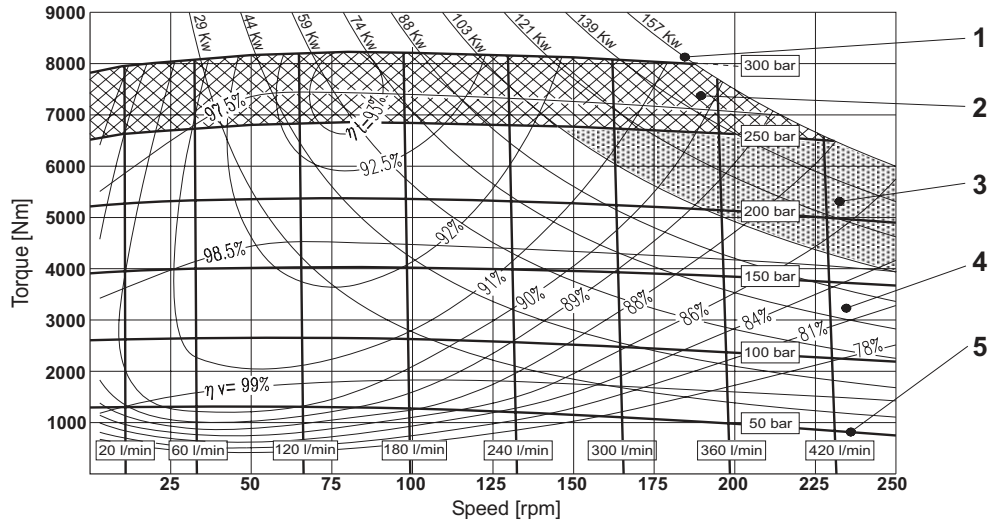

**MRD 1800
 MRV 1800**

set to
603 cm³

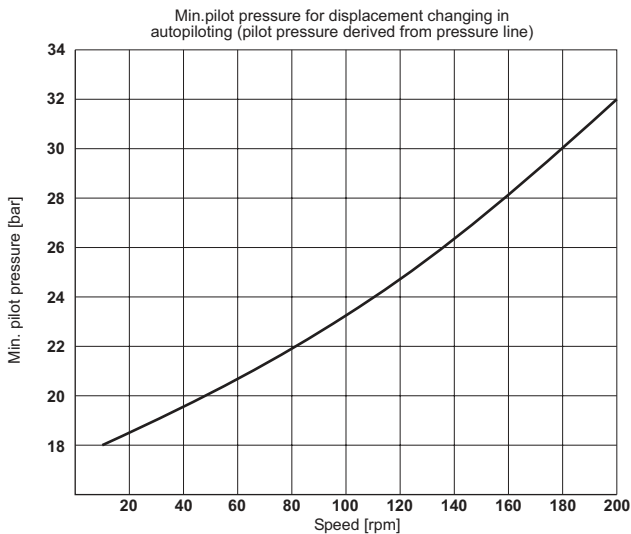
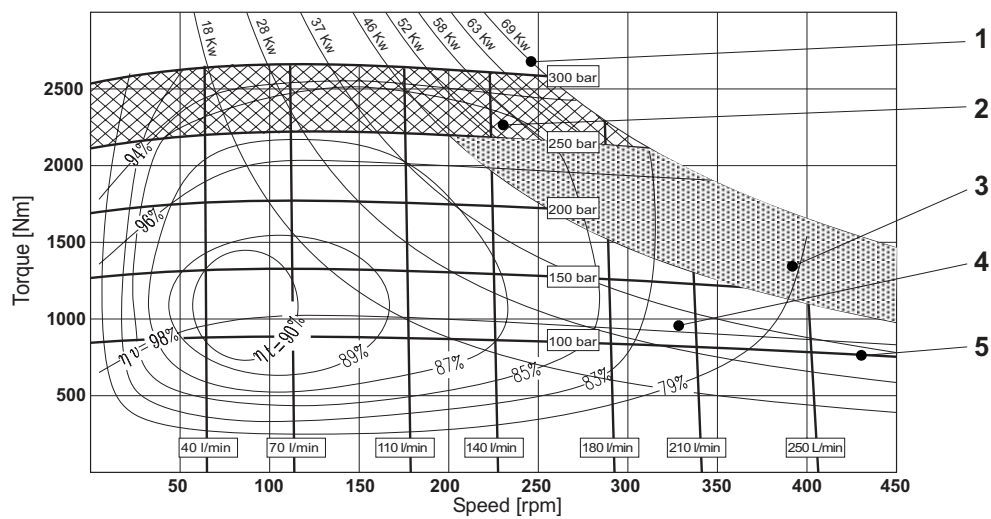

Valid for back pressure up to 50 bar, drain pressure up to 5 bar.
 For other working conditions please consult DENISON Calzoni

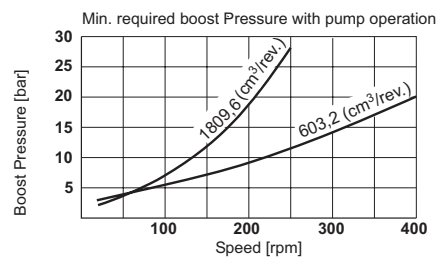
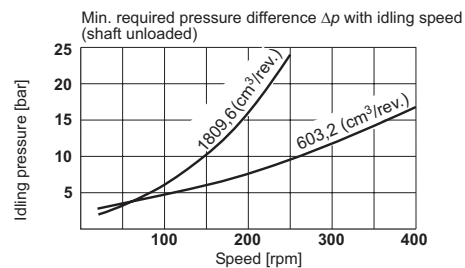

Operating diagram

(average values) measured at $v = 36 \text{ mm}^2/\text{s}$; $t = 45^\circ\text{C}$; $p_{\text{outlet}} = 0 \text{ bar}$

- 1** Output power **2** Intermittent operating area
- 3** Continuous operating area with flushing
- 4** Continuous operating area
- 5** Inlet pressure η_t Total efficiency η_v Volumetric efficiency

MRDE 2100
MRVE 2100

set to
2091 cm³

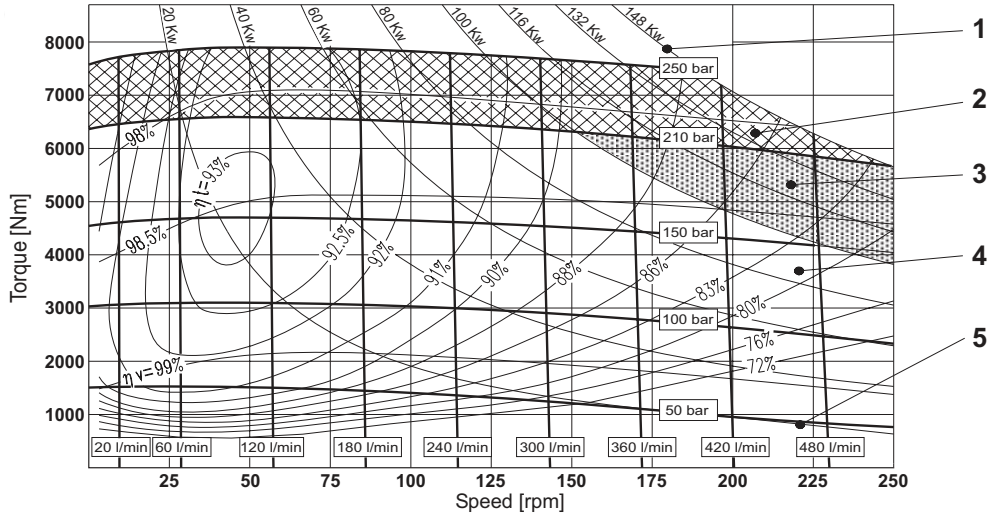

MRDE 2100
MRVE 2100

set to
697 cm³

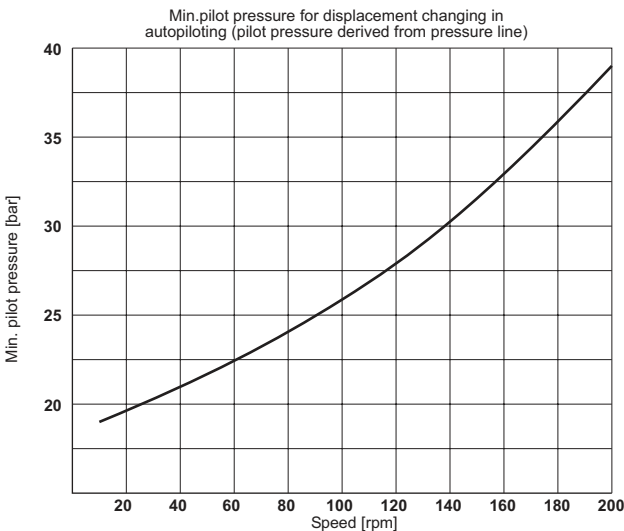
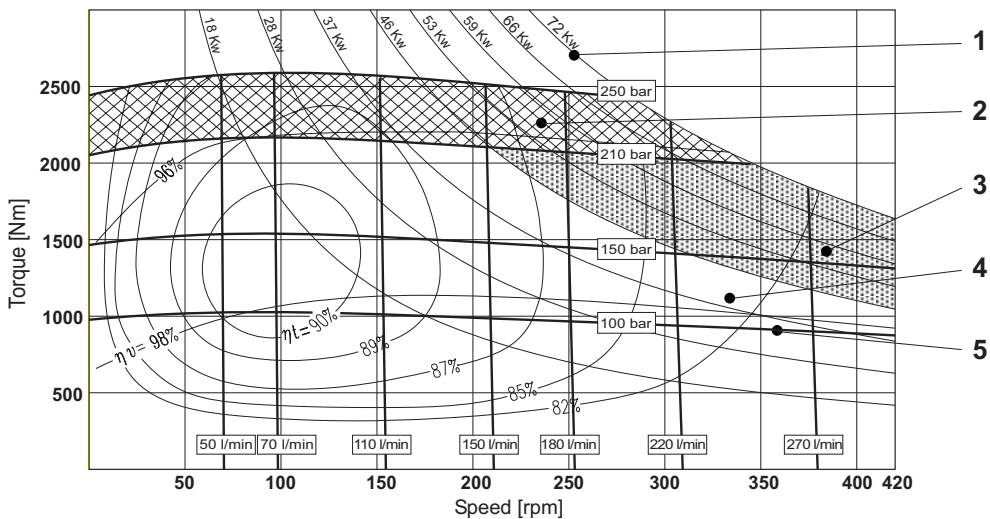

Valid for back pressure up to 50 bar, drain pressure up to 5 bar.
 For other working conditions please consult PARKER Calzoni

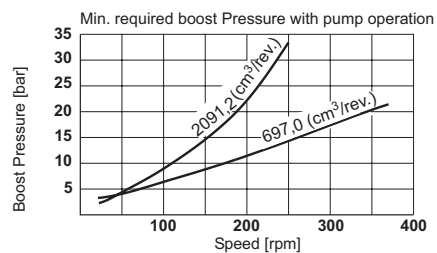
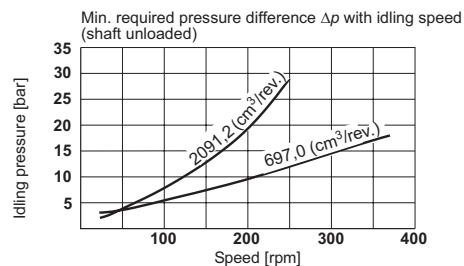

Operating diagram

(average values) measured at $v = 36 \text{ mm}^2/\text{s}$; $t = 45^\circ\text{C}$; $p_{\text{outlet}} = 0 \text{ bar}$

- 1 Output power
- 2 Intermittent operating area
- 3 Continuous operating area with flushing
- 4 Continuous operating area
- 5 Inlet pressure
- η_t Total efficiency
- η_v Volumetric efficiency

MRD 2800
MRV 2800

set to
2792 cm³

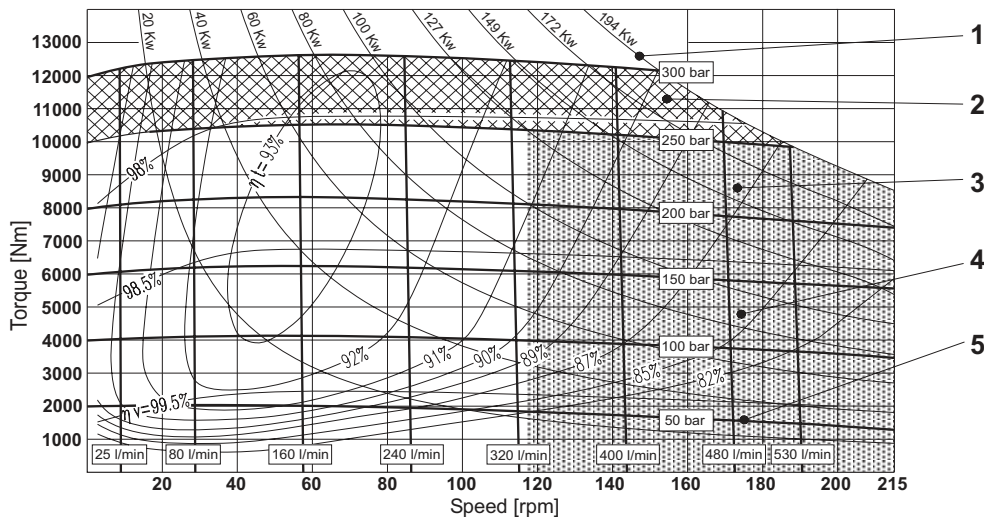

MRD 2800
MRV 2800

set to
931 cm³

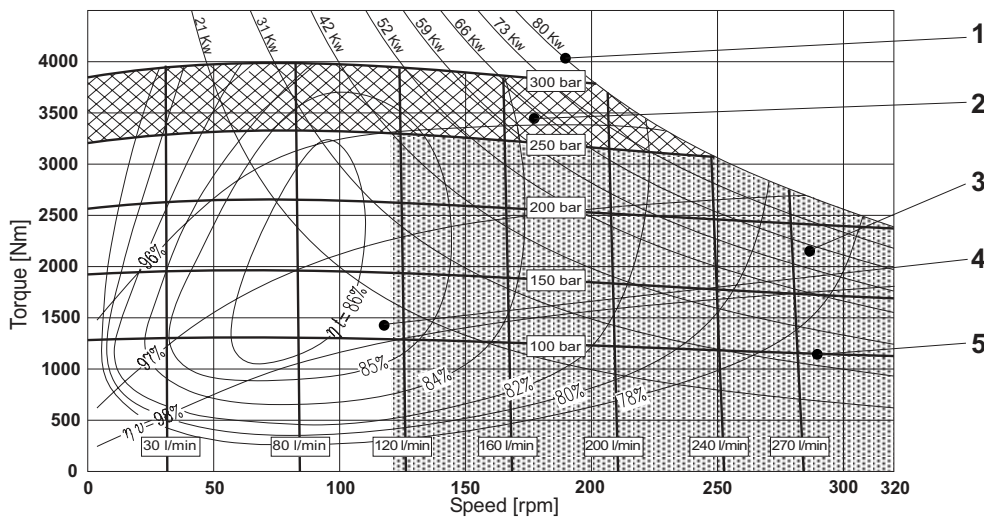

Min. pilot pressure for displacement changing in autopiloting (pilot pressure derived from pressure line)

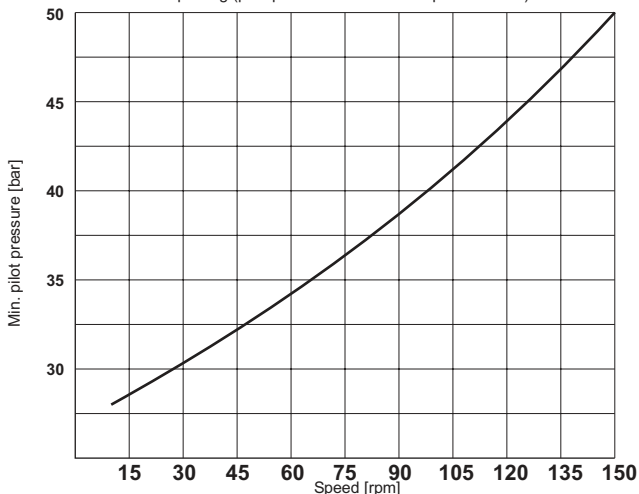

Valid for back pressure up to 50 bar, drain pressure up to 5 bar.
For other working conditions please consult PARKER Calzoni

Min. required pressure difference Δp with idling speed (shaft unloaded)

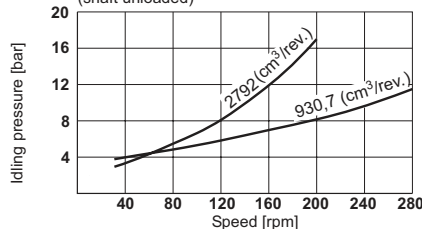

Min. required boost Pressure with pump operation

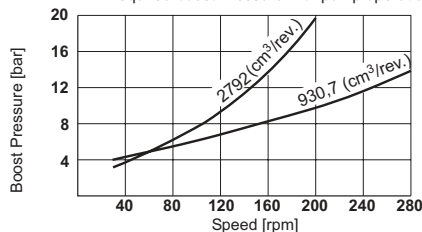

Operating diagram

(average values) measured at $v = 36 \text{ mm}^2/\text{s}$; $t = 45^\circ\text{C}$; $p_{\text{outlet}} = 0 \text{ bar}$

- 1** Output power **2** Intermittent operating area
- 4** Continuous operating area **5** Inlet pressure η_t Total efficiency η_v Volumetric efficiency

MRDE 3100
MRVE 3100

set to
3104 cm³

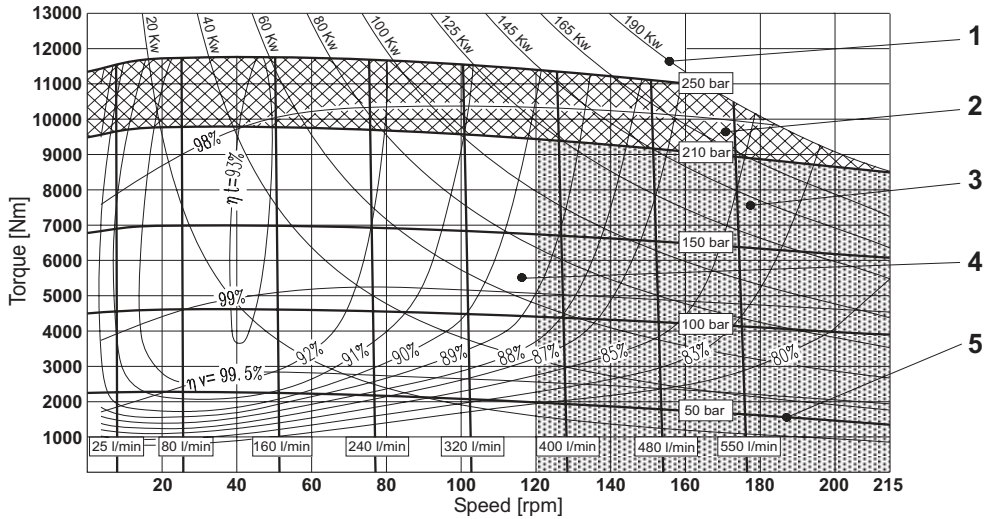

MRDE 3100
MRVE 3100

set to
1035 cm³

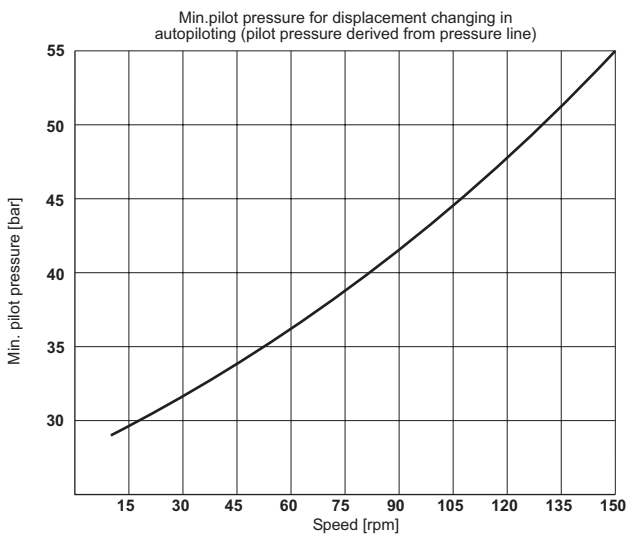
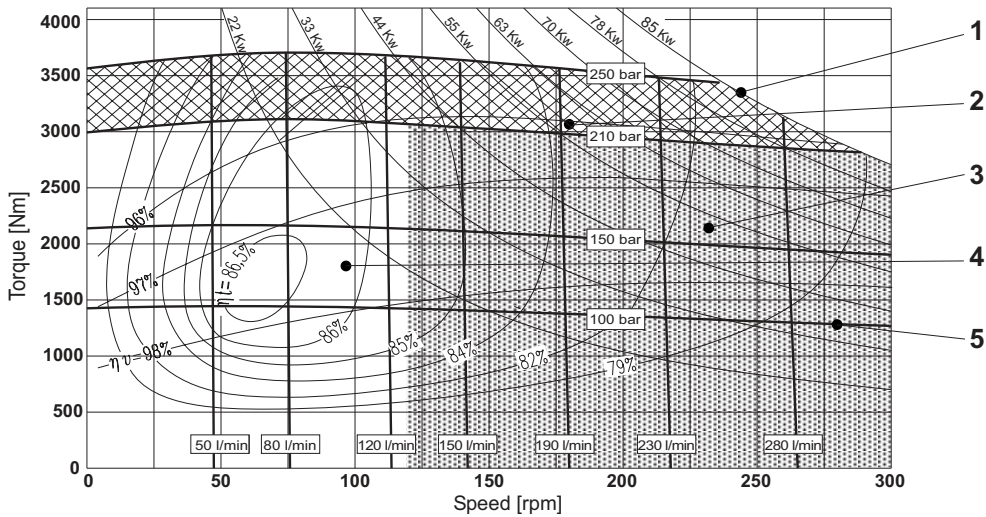

Valid for back pressure up to 50 bar, drain pressure up to 5 bar.
 For other working conditions please consult PARKER Calzoni

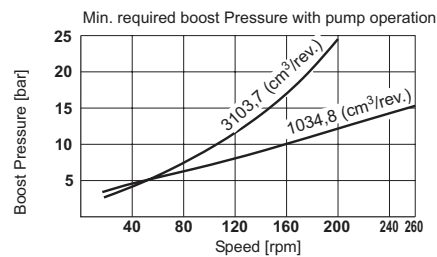
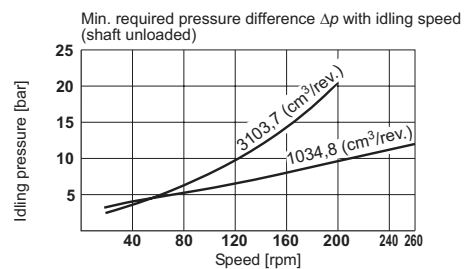

Operating diagram

(average values) measured at $v = 36 \text{ mm}^2/\text{s}$; $t = 45^\circ\text{C}$; $p_{\text{outlet}} = 0 \text{ bar}$

- 1** Output power **2** Intermittent operating area
- 4** Continuous operating area **5** Inlet pressure η_t Total efficiency η_v Volumetric efficiency

MRD 4500
MRV 4500

set to
4502 cm³

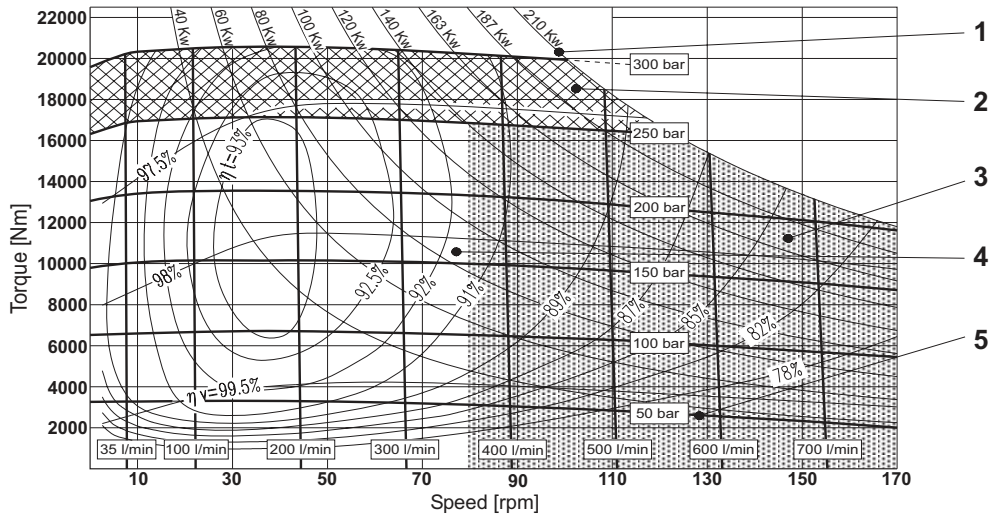

MRD 4500
MRV 4500

set to
1560 cm³

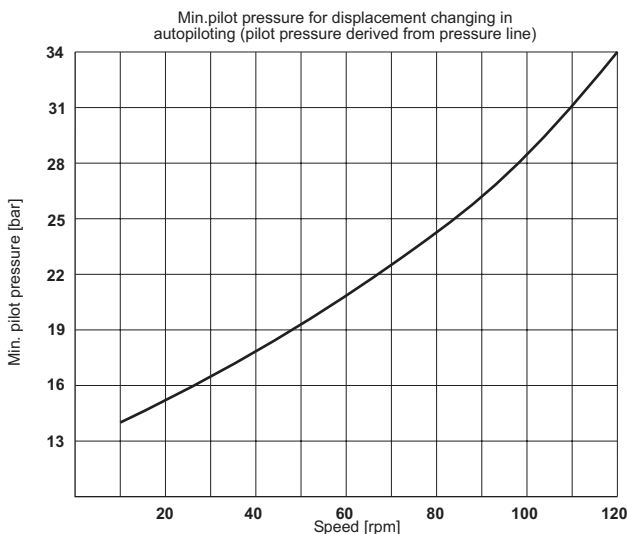
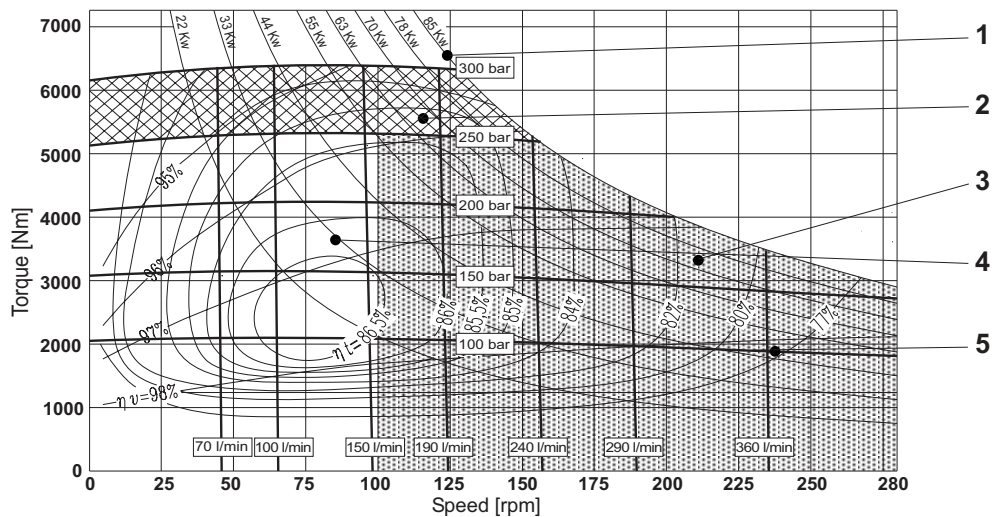

Valid for back pressure up to 50 bar, drain pressure up to 5 bar.
 For other working conditions please consult PARKER Calzoni

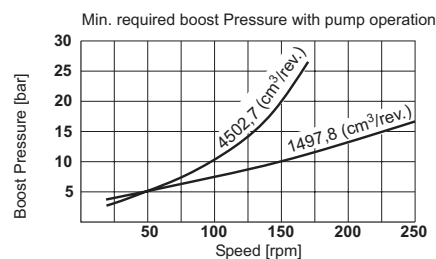
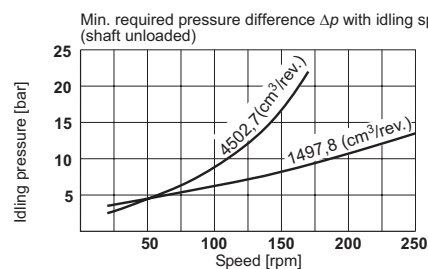

Operating diagram

(average values) measured at $v = 36 \text{ mm}^2/\text{s}$; $t = 45^\circ\text{C}$; $p_{\text{outlet}} = 0 \text{ bar}$

- 1** Output power **2** Intermittent operating area
- 3** Continuous operating area with flushing
- 4** Continuous operating area
- 5** Inlet pressure η_t Total efficiency η_v Volumetric efficiency

MRDE 5400
MRVE 5400

set to
5401 cm³

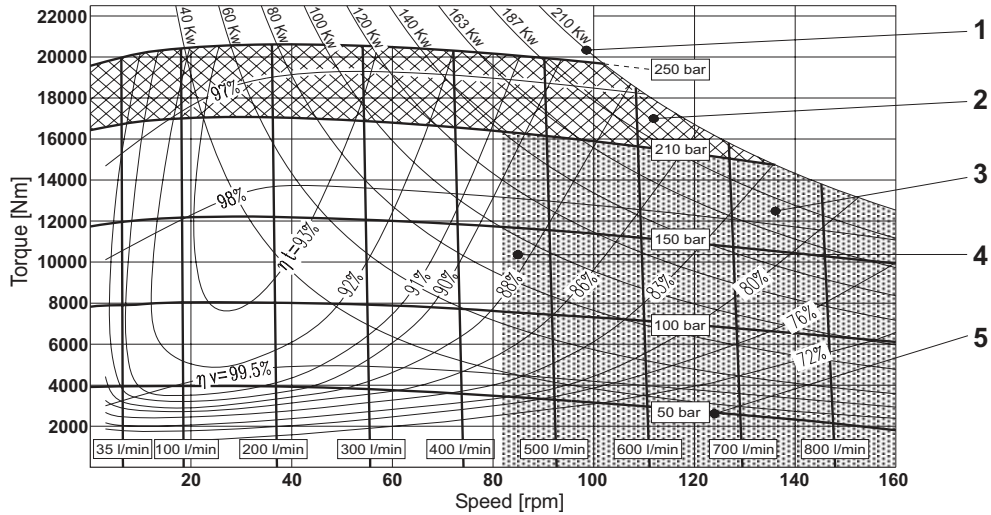

MRDE 5400
MRVE 5400

set to
1870 cm³

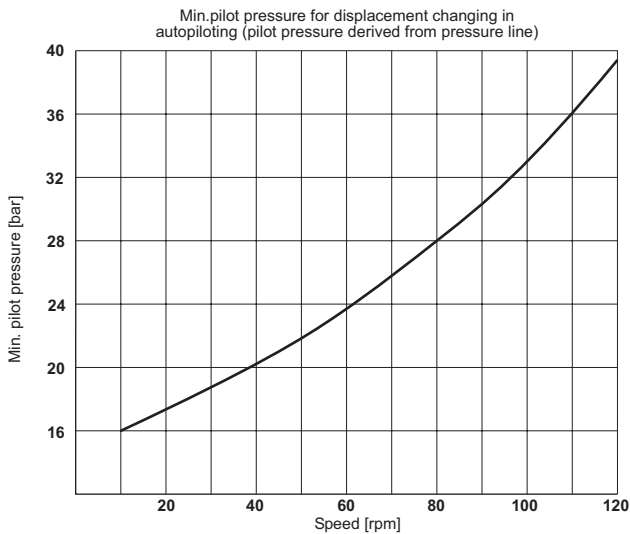
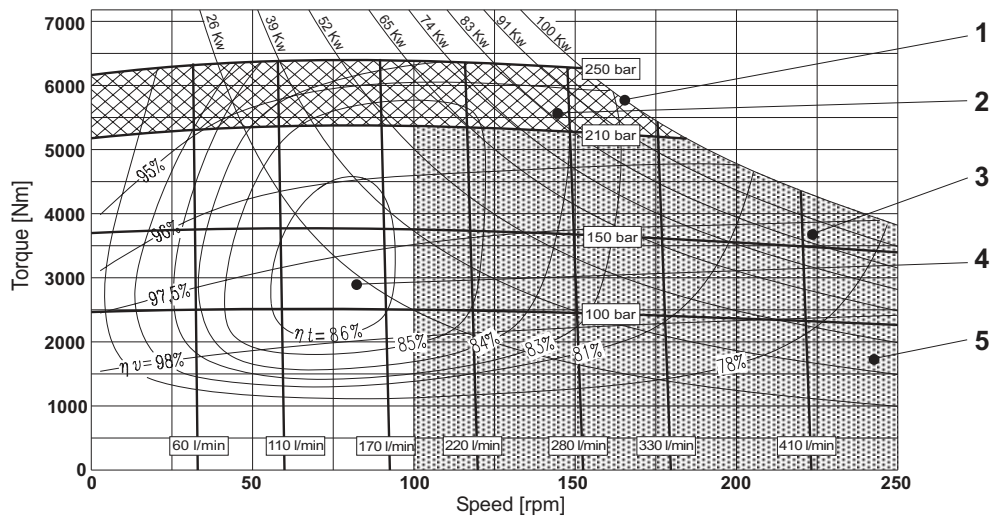

Valid for back pressure up to 50 bar, drain pressure up to 5 bar.
 For other working conditions please consult PARKER Calzoni

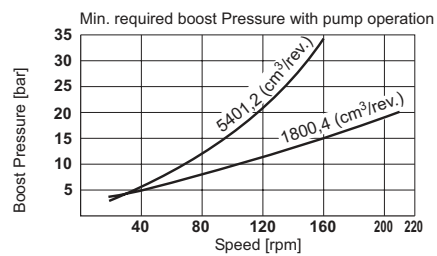
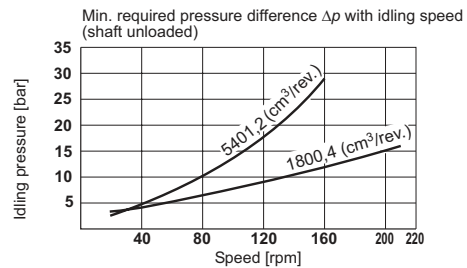

Operating diagram

(average values) measured at $v = 36 \text{ mm}^2/\text{s}$; $t = 45^\circ\text{C}$; $p_{\text{outlet}} = 0 \text{ bar}$

- 1** Output power **2** Intermittent operating area
- 3** Continuous operating area with flushing
- 4** Continuous operating area
- 5** Inlet pressure η_t Total efficiency η_v Volumetric efficiency

MRD 7000

set to
6967 cm³

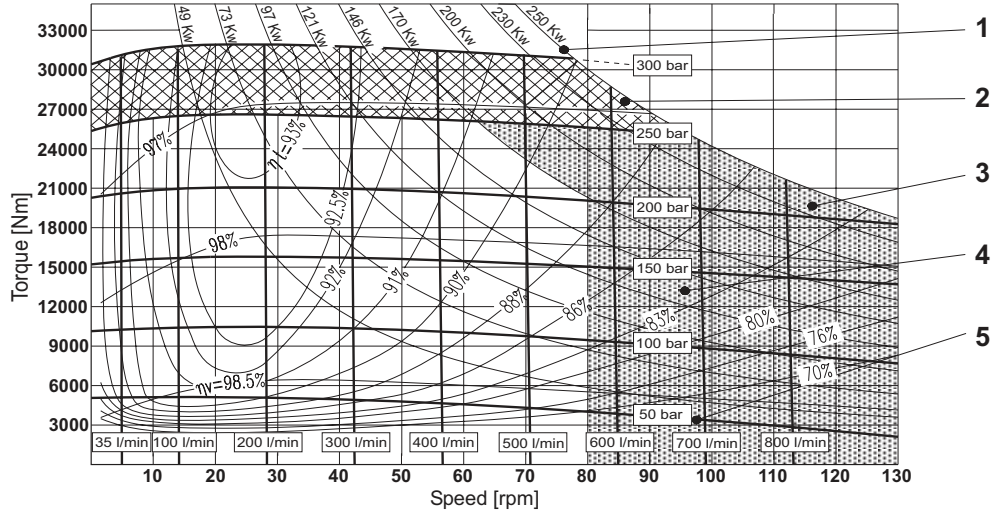

MRD 7000

set to
2280 cm³

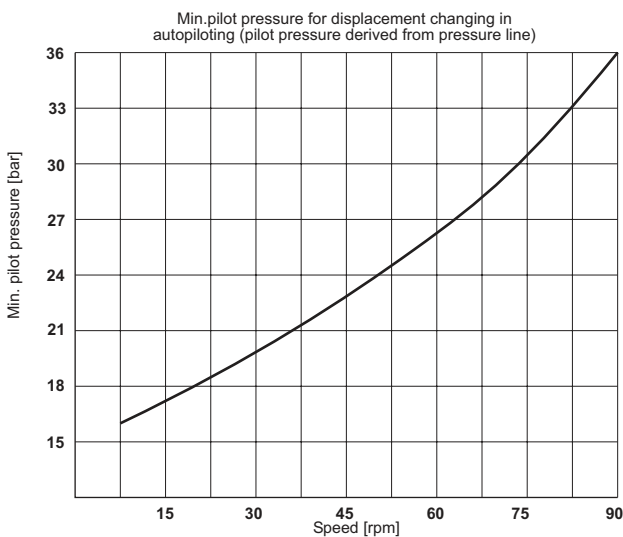
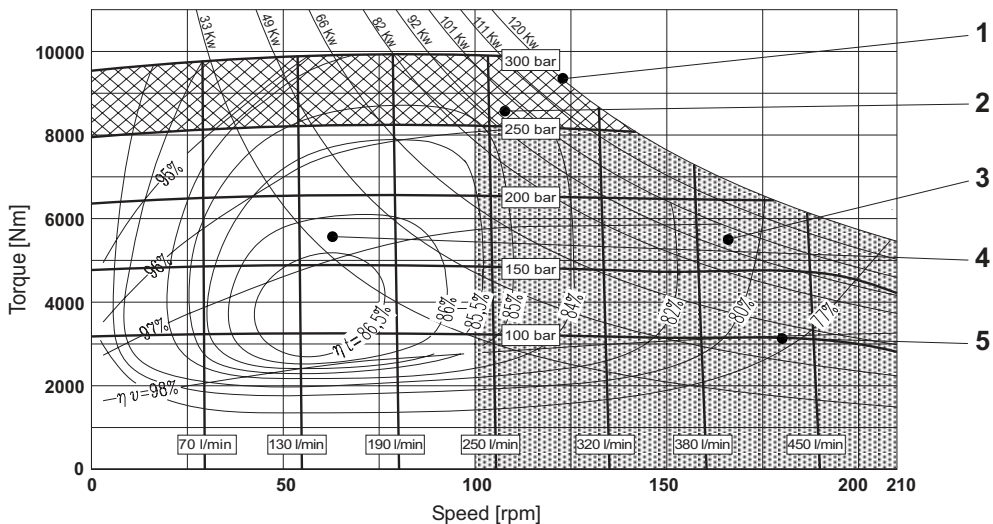

Valid for back pressure up to 50 bar, drain pressure up to 5 bar.
 For other working conditions please consult PARKER Calzoni

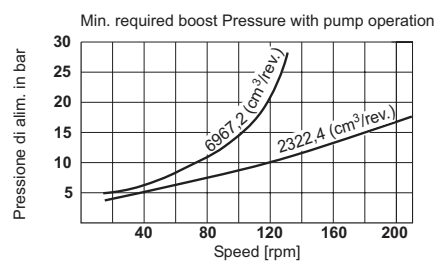
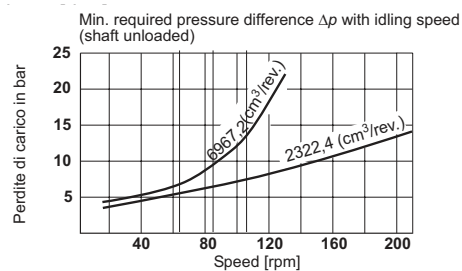

Motor without brake: drain and flushing connections (installation examples)

Position the case drain pipe, so that the motor cannot run empty. Low pressure case drain returns to tank.

Horizontal mounting

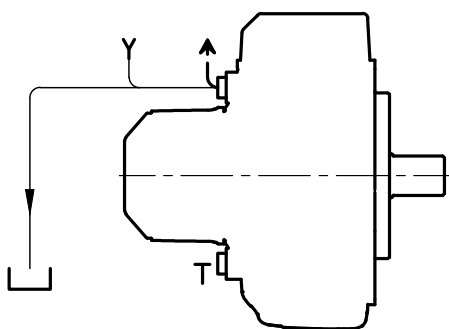

Vertical mounting, shaft downwards

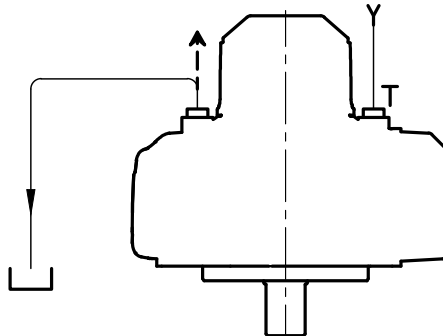

Horizontal mounting, tank located in higher position

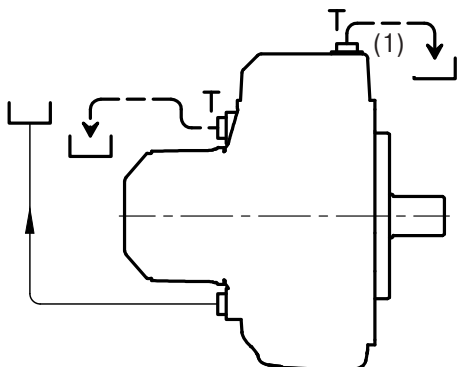

(1) = Bleed screw (on enquiry)

Vertical mounting, shaft downwards, tank located in higher position

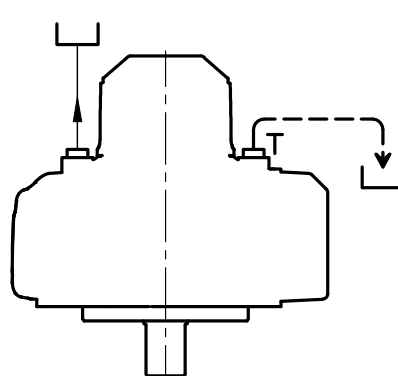

Cooling circuit for high power continuous operation

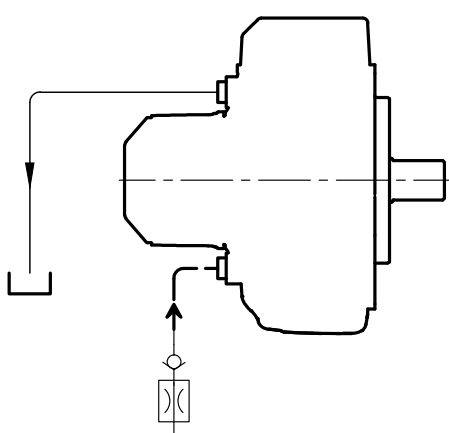

Vertical mounting, shaft upwards

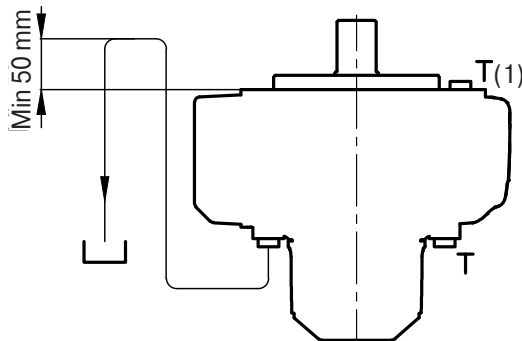

(1) = Bleed screw (on enquiry)

T = Seal

Y = Motor housing feeding line

--> = Air bleed

Motor with brake: drain and flushing connections (installation examples)

Position the case drain pipe, so that the motor cannot run empty. Low pressure case drain returns to tank.
 Motor without shaft seal used with brake.

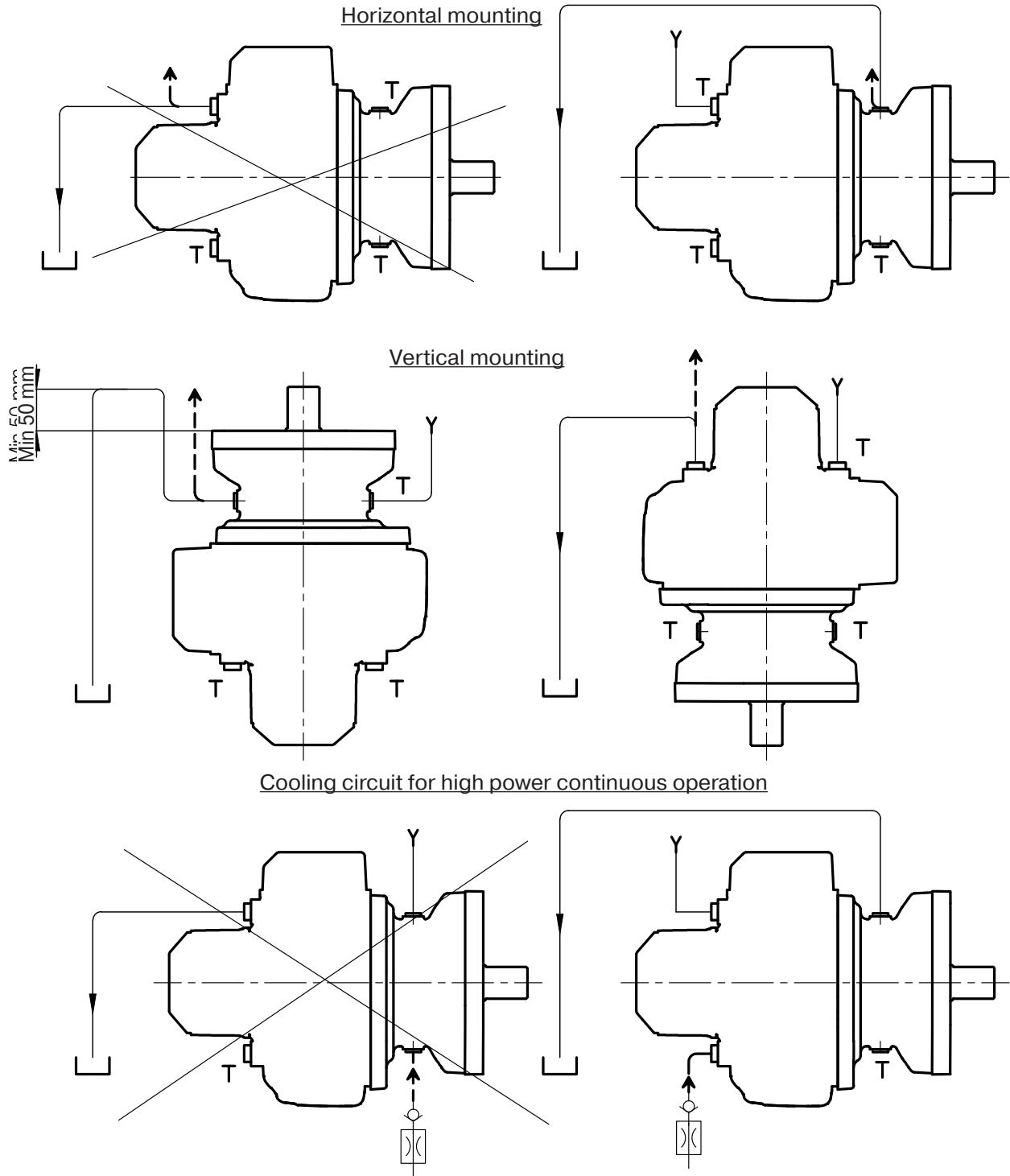

T = Seal

Y = Motor housing feeding line

---> = Air bleed

Motor start-up

The motor does not require any special running in, but all residual impurities in the system must be eliminated by running the motor at low speed and with no applied load, granting the minimum necessary inlet pressure.

After a brief period in service, the system filters should be cleaned. This operation will also lead to the air venting from motor cylinders; air inside the motor cylinders may increase the possible noise at the start-up of the motor. Make sure the motor case has been filled (see “Motor case oil filling” paragraph).

Piloting pressure is always needed for MRD/MRV motors. For motors with external piloting configuration, an external pressure line must be connected to piloting port.

Motor case oil filling

All motors are supplied without lubricating oil. Before start-up, the motor case must be filled in by using the same hydraulic oil used to operate the motor.

The two case drain holes are both plugged, one with a metal plug and the other one with a plastic plug. To fill in the motor case it is necessary:

- to place the motor in its working position, making sure to close the lower case drain hole by means of the metal plug;
- to use the upper case drain hole to fill in the motor case up to the level required, by using the same hydraulic oil used in the system, in order to ensure the perfect lubrication of the two bearings.

The volume of oil necessary to fill in the case has to be selected according to the motor size (see table below):

Motor type	Motor case oil		Motor type	Motor case oil		Motor type	Motor case oil	
	liters	gallons		liters	gallons		liters	gallons
MRD 330 D	2.0	0.53	MRD 1100 G	6.0	1.58	MRD 2800 I	13.0	3.43
MRDE 330 D			MRDE 1100 G			MRDE 3100 I		
MRD 450 E	MRV 1100 G	MRV 2800 I						
MRDE 500 E	2.8	0.74	MRVE 1400 G	9.5	2.50	MRVE 3100 I	19.0	5.02
MRV 450 E			MRD 1800 H			MRD 4500 L		
MRD 700 F	MRDE 2100 H	MRDE 5400 L						
MRDE 800 F	MRV 1800 H	MRV 450 L						
MRV 700 F	3.3	0.87	MRVE 2100 H	27.0	7.13	MRVE 5400 L	27.0	7.13
MRVE 800 F			MRD 7000 M					

Motor case filling volume

Flushing of motor case

Operating within the “Continuous operating area without flushing” (number 4 in operating diagrams from page 34 to page 47 - according to motor type) does not require any additional cooling of the motor case.

For operating conditions out of the “Continuous operating area without flushing”, additional cooling oil is required to avoid high temperature in the motor case (areas number 2 and 3 in operating diagrams from page 34 to page 47 - according to motor type).

Flushing can be also necessary when the operating performances are inside the “Continuous operating area without flushing”, but the system is not able to ensure the minimum viscosity conditions requested by the motor as specified at pages 32 and 33.

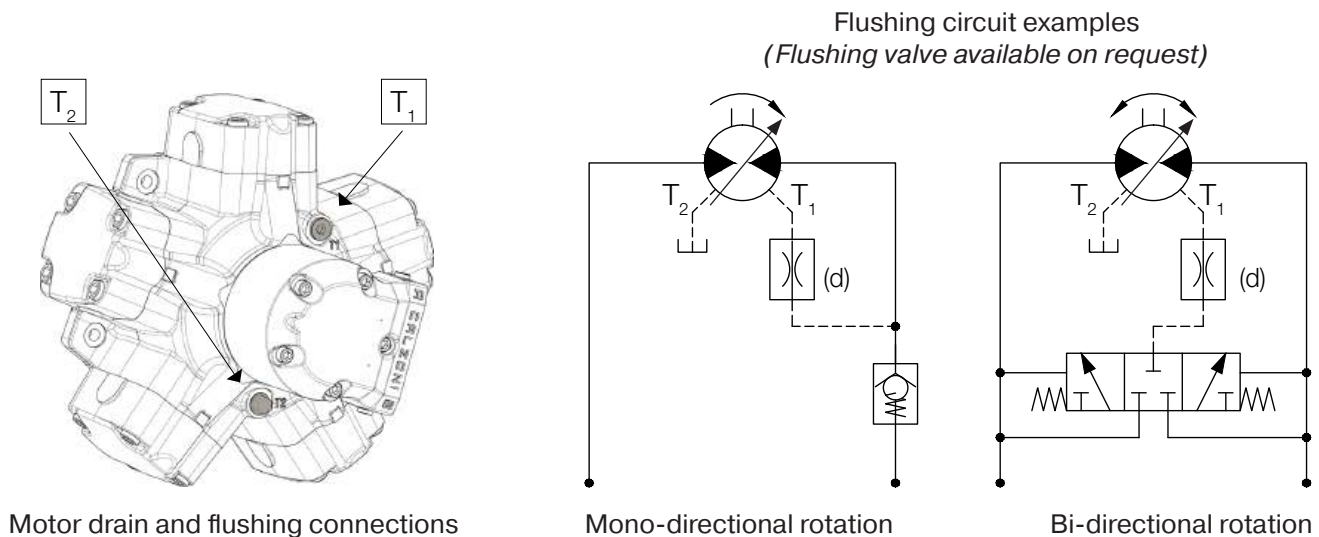

Motor type	Motor case oil	
	liters	gallons
MRD 330 D	6	1.6
MRDE 330 D		
MRD 450 E	8	2.1
MRDE 500 E		
MRV 450 E	10	2.6
MRD 700 F		
MRDE 800 F		
MRV 700 F		
MRVE 800 F		

Motor type	Motor case oil	
	liters	gallons
MRD 1100 G	10	2.6
MRDE 1100 G		
MRV 1100 G		
MRVE 1400 G	15	4.0
MRD 1800 H		
MRDE 2100 H		
MRV 1800 H		
MRVE 2100 H		

Motor type	Motor case oil	
	liters	gallons
MRD 2800 I	20	5.3
MRDE 3100 I		
MRV 2800 I		
MRVE 3100 I	20	5.3
MRD 4500 L		
MRDE 5400 L		
MRV 450 L		
MRVE 5400 L		
MRD 7000 M	20	5.3

Motor case filling volume

General information

Bearing life can be calculated for that part of the load/life curve (shown below) that is designated 'Bearing fatigue'. 'Components wear' and 'Other causes', caused by material fatigue and fluid contamination, should also be taken into consideration when estimating the service life of a motor in a specific application.

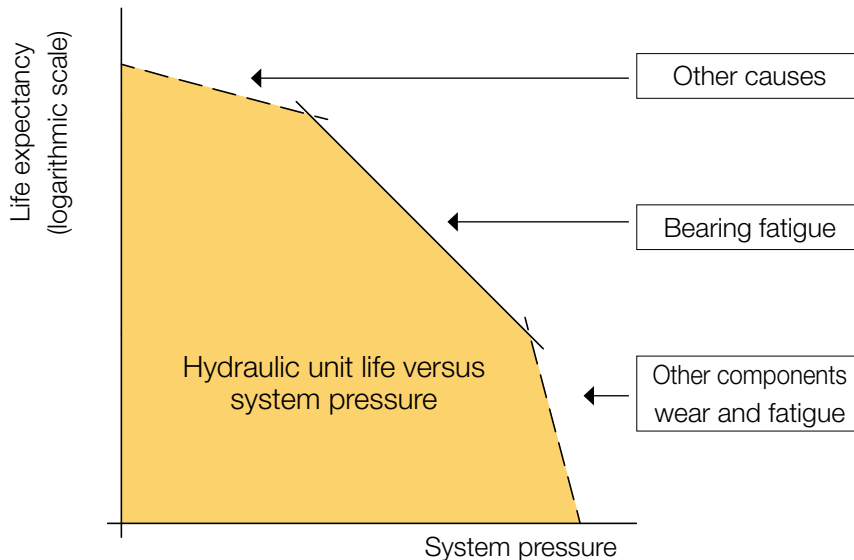

Bearing life (in hours), depends on system pressure, operating speed, external shaft loads, fluid viscosity in the case, and fluid contamination level. When the motors operate inside the catalogue parameters, the bearing life can be equated to the motor life (service life of the motor before maintenance).

Bearing service life

Bearing L10h life (in hours) can be calculated according to motor speed and pressure (see below formulas, metric unit on the left, imperial/US unit on the right):

$$L_{10h} = \frac{16\,666}{n} \left(\frac{K}{p} \right)^{3.33}$$

p = pressure (bar)
n = speed (rpm)

$$L_{10h} = \frac{16\,666}{n} \left(\frac{14.5 \cdot K}{p} \right)^{3.33}$$

p = pressure (psi)
n = speed (rpm)

L10h is the basic rating life at 90% reliability: it means that 90% of the bearings survive at least the calculated number of hours. Statistically, 50% of the bearings will survive at least five times the L10h life.

Motor type	K	Motor type	K	Motor type	K
MRD 300 D	1280	MRVE 1400 G	920	MRD 4500 L	1170
MRDE 330 D	1170	MRD 1800 H	1040	MRDE 5400 L	980
MRD 450 E	1500	MRDE 2100 H	900	MRV 4500 L	1170
MRDE 500 E	1360	MRV 1800 H	1040	MRVE 5400 L	980
MRV 450 E	1500	MRVE 2100 H	900	MRD 7000 M	900
MRD 700 F	1240	MRD 2800 I	1140		
MRDE 800 F	1090	MRDE 3100 I	1020		
MRV 700 F	1360	MRV 2800 I	1140		
MRVE 800 F	1090	MRVE 3100 I	1020		
MRD 1100 G	1120				
MRDE 1400 G	920				
MRV 1100 G	1120				

Under variable operating conditions bearing life can be predicted using the equation:

$$L10h = \frac{1}{\frac{U_1}{L10h_1} + \frac{U_2}{L10h_2} + \frac{U_3}{L10h_3} + \dots}$$

Where:

L10h = rating life (hours)

L10h₁, L10h₂, ... = fraction rating lives under constant conditions 1, 2, ... (hours)

U₁, U₂, ... = life fraction under the conditions 1, 2, ... (Note: U₁+U₂+...+U_n=1)

Calzoni motors are designed with bearings that can accept external radial loads. External radial shaft loads impact unit lifetime and the bearing life will be a function of the load position, orientation and operating conditions. In applications with external radial shaft loads, minimize the impact by positioning the load close to the motor mounting surface.

Please contact Calzoni to determine motor life in a specific application, taking into consideration also external shaft forces and fluid viscosity.



Calzoni Hydraulics Germany GmbH

Max-Eyth-Straße 65
72622 Nürtingen, Germany
Phone: +49 7022 405990

Calzoni Hydraulics Italy Srl

Via Casteldebole 10
40069 Zola Predosa (BO) Italy
Phone: +39 051 6501611

Email: info@calzoni-hydraulics.com

Catalogue CH-MRD-0502.0/EN 2024